



Primary Clinical Care Manual

11th edition 2022



Royal Flying Doctor Service
QUEENSLAND SECTION



Queensland
Government

Criteria for early notification of trauma for interfacility transfer¹

ALL trauma patients - do rapid assessment of **vital signs, injuries** and **mechanism of injury**

	Adult	Newborn ◀ 4 weeks	Infant 1 – 12 mths	Child 1 – 8 years	Child 9 – 15 years	
Vital signs	Respiratory rate/minute	◀ 10 or ▶ 30	◀ 40 or ▶ 60	◀ 20 or ▶ 50	◀ 20 or ▶ 35	◀ 15 or ▶ 25
	SpO ₂ on room air	◀ 90%	◀ 95%	◀ 95%	◀ 95%	◀ 95%
	Systolic BP mmHg	◀ 90	n/a	◀ 60	◀ 70	◀ 80
	HR/minute	▶ 120	◀ 100 or ▶ 170	◀ 90 or ▶ 170	◀ 75 or ▶ 130	◀ 65 or ▶ 120
	GCS	◀ 14	Altered LOC	Altered LOC	Altered LOC	Altered LOC

Injuries
<ul style="list-style-type: none"> • All penetrating injuries <ul style="list-style-type: none"> – head/neck/chest/abdomen/pelvis/axilla • Blunt injuries <ul style="list-style-type: none"> – patients with significant injuries to a single region - head/neck/chest/abdomen/pelvis/axilla – patients with injuries involving 2 or more of the above body regions • Specific injuries <ul style="list-style-type: none"> – limb amputation/life threatening injuries – suspected spinal cord injury – burns: adult > 20% BSA (child > 10%) – suspected respiratory tract burns – serious crush injury – major compound fracture or open dislocation – fracture to 2 or more: femur, tibia, humerus – fractured pelvis

Mechanism of injury	
<ul style="list-style-type: none"> • Ejection from vehicle • Motorcyclist impact > 30 kph • High speed motor vehicle collision > 60 kph • Vehicle roll over • Fatality in same vehicle 	<ul style="list-style-type: none"> • Prolonged extrication > 30 minutes • Pedestrian impact • Fall from height > 3 metres • Struck on head by falling object > 3 metres • Explosion

If ANY of the above are present PROMPTLY CALL

RSQ ☎ 1300 799 127

for management support, retrieval advice and destination decision
or your local/state trauma escalation service

If none of the above is present, follow usual local processes for assessment and transfer of the patient

Primary Clinical Care Manual 11th edition 2022 (reprinted March 2023)

Includes updates as of March 2023

ISBN: 978-1-876560-15-7 (A5); 978-1-876560-16-4 (spiral bound)

© 2022 State of Queensland (Queensland Health) and Royal Flying Doctor Service (Queensland Section)

Comments and feedback

Please email: pccm@health.qld.gov.au

Suggested citation

Queensland Health, Royal Flying Doctor Service (Queensland Section). Primary Clinical Care Manual. 11th ed. Cairns (AU): Office of Rural and Remote Health, Queensland Government; 2022.

Controlled and uncontrolled versions

The online version is the controlled copy of the Primary Clinical Care Manual. Downloaded and hard copies are uncontrolled. Users are responsible for accessing the controlled copy, available at:

<https://www.health.qld.gov.au/rrcsu/html/PCCM>

Copying and reproduction

This work is licensed under a Creative Commons Attribution Non-Commercial Share Alike 4.0 International licence (CC BY-NC-SA 4.0). You are free to copy, communicate and adapt the work for non-commercial purposes, as long as you attribute the State of Queensland (Queensland Health) and the Royal Flying Doctor Service (Queensland Section), you distribute any derivative work only under the same licence and you comply with the licence terms. To view a copy of this licence visit:

<http://creativecommons.org/licenses/by-nc-sa/4.0/deed.en>



For copyright permissions beyond the scope of this licence contact: Senior Policy Officer (Intellectual Property), Office of Precision Medicine and Research, Queensland Health

Email: ip_officer@health.qld.gov.au ☎ 07 3708 5069

Cover Images © 2022 Royal Flying Doctor Service (Queensland Section) and Queensland Health

Disclaimer

The Primary Clinical Care Manual 11th edition 2022 is distributed by Queensland Health and the Royal Flying Doctor Service (Queensland Section) as an information source only and does not replace clinical judgment. The information is provided solely on the basis that readers will be responsible for making their own assessment of the matters presented herein and readers are advised to verify all relevant representations, statements and information. The information does not constitute clinical advice and should not be relied upon as such. Specialist advice in relation to the application of the information presented in this publication must be sought as necessary to ensure the application is clinically appropriate

In no event shall Queensland Health or the Royal Flying Doctor Service of Australia (Queensland Section) be liable (including liability for negligence) for any claim, action, proceeding, demand, liability, costs, damages, expenses or loss (including without limitation, direct, indirect, punitive, special or consequential) whatsoever brought against or made upon or incurred by Queensland Health or the Royal Flying Doctor Service of Australia (Queensland Section) arising out of or in connection with a person's use of or reliance on or inability to use the information or instructions provided in this publication, or incorporated into this publication by reference

Contents

Foreword	1
Acknowledgements	4
Introduction	10
1. Patient assessment and transport	
Patient presentation	16
Adult presentation	17
History and physical examination	17
Clinical consultation	25
Patient retrieval/evacuation	26
2. Pain, nausea and vomiting	
Acute pain	32
Nausea and vomiting	40
3. Emergency	
Resuscitation	46
Basic life support (BLS)	46
Advanced life support (ALS)	48
Oxygen delivery	53
Laryngeal mask airway (LMA) insertion	56
Intraosseous access	57
Critical emergencies	60
Unconscious/altered level of consciousness	60
Shock	62
Sepsis/septic shock	64
Meningitis	72
Choking (foreign body airway obstruction)	78
Button battery ingestion/insertion	80
Anaphylaxis	82
Fitting	86
Diabetic ketoacidosis (DKA)	89
Hypoglycaemia	91
Acute asthma	95
Drowning/submersion	101
Cardiovascular emergencies	103
Chest pain assessment	103
Acute coronary syndrome (ACS)	107
Acute pulmonary oedema (cardiac causes)	113
Hypertensive emergency	116

Arrhythmias	119
Electrocution/electric shock	121
Acute lower leg ischaemia	123
Deep vein thrombosis (DVT)	124
Pulmonary embolism (PE)	125
Neurological emergencies	127
Headache	127
Transient ischaemic attack (TIA) and stroke	130
Delirium	131
Traumatic injuries	134
Traumatic injuries	134
Chest injuries	140
Head injuries	143
Spinal injuries	147
Abdominal injuries	150
Fractures, dislocations and sprains	152
Simple fracture of limbs	152
Open (compound) fractures	154
Fractured pelvis	156
Fractured jaw	157
Dislocations	158
Sprains/soft tissue injury	159
Compartment syndrome	160
Acute wounds	162
Acute wounds	162
Removal of small fish hook	169
Removal of tight ring	170
Water related wounds	170
Human (tooth-knuckle) and animal bites	173
Bat bite/scratch	176
Burns	177
Burns	177
Minor burns	181
Chemical contact burns	182
Environmental emergencies	185
Decompression illness (DCI/bends)	185
Hypothermia	186
Hyperthermia	188
Ears, nose and throat (ENT) emergencies	190
Nose bleed/epistaxis	190
Traumatic rupture of eardrum	193
Foreign body in ear or nose	194
Gastrointestinal emergencies	196

Acute abdominal pain	196
Abdominal pain causes	199
Gastroenteritis/dehydration	200
Gastritis	202
Upper gastrointestinal bleeding	203
Rectal bleeding	204
Bowel obstruction	205
Genitourinary emergencies	206
Renal colic	206
Acute retention of urine	208
Testicular/scrotal pain	209
Poisoning and overdose	211
Bites and stings	222
Snake bite	222
Funnel-web (big black) spider bite	225
Red-back spider bite	227
Spider bites (other)	228
Scorpion stings and centipede bites	229
Tick bites	230
Box jellyfish stings	231
Irukandji syndrome	233
Bluebottle and other jellyfish stings	234
Blue-ringed octopus and cone shell envenomation	235
Penetrating marine injuries	236
Sponges	238
Ciguatera poisoning	239
Stinging tree	240
Assault	241
Domestic and family violence	241
Sexual assault	243
4. General	
Mild and moderate allergic reactions	248
Urticaria, allergic rhinitis	248
Respiratory problems	250
Upper respiratory tract infection (URTI)	250
Acute bacterial sinusitis	252
Pneumonia	253
Tuberculosis	255
Mouth and dental problems	257
Trauma to teeth	257
Toothache	261
Dental caries	263
Mouth ulcers	265

Tooth abscess	267
Post tooth extraction bleeding	270
Dry socket	271
Gum disease	272
Oral thrush	274
Eye problems	276
Eye assessment	276
Eye differential diagnosis	280
Foreign body in eye	281
Corneal abrasion	283
Flash burn to eye	284
Chemical burn to eye	285
Eye injury	286
Sudden, painless loss of vision	287
Orbital/periorbital cellulitis	288
Conjunctivitis	290
Trachoma	293
Urinary tract problems	295
Urinary tract infection (UTI)	295
Skin problems	298
Impetigo	298
Boils	302
Cellulitis	306
Shingles	309
Tinea/ringworm	311
Candidiasis (skin)	313
Tinea versicolor (pityriasis versicolor)	314
Leprosy (Hansen's disease)	315
Scabies	316
Head lice/nits	319
Nappy rash	320
Diabetic foot infection ± osteomyelitis	321
Chronic wounds	323
Swollen/painful joints	325
Acutely swollen/painful joint	325
Gout	326
Mosquito borne diseases	327
Chronic conditions	330
Secondary prophylaxis for acute rheumatic fever (ARF)	330
Supply of chronic condition medicines by A&TSIHP and IHW	332
5. Mental health and alcohol withdrawal	
Mental health	336
Mental health emergency	336

Suicidal behaviour	344
Dementia	348
Psychosis	350
Mood disorders	352
Panic attack	354
Alcohol withdrawal	356

6. Obstetrics and neonatal

Antenatal	362
Termination of pregnancy (ToP)	362
Antenatal care	364
Rh D immunoglobulin	369
Pregnancy complications	371
Ectopic pregnancy	371
Vaginal bleeding in early pregnancy	373
Urinary tract infection (UTI) in pregnancy	375
Diabetes in pregnancy	378
Hypertension in pregnancy	383
Preeclampsia/eclampsia	386
Antepartum haemorrhage (APH)	390
Prelabour rupture of membranes (PROM)	392
Labour and birth	395
Group B Streptococcus prophylaxis	395
Preterm labour	397
Labour 1st stage	400
Imminent birth	403
Neonatal resuscitation	408
Care of the newborn	412
Emergencies in labour and birth	415
Cord prolapse	415
Primary postpartum haemorrhage (PPH)	417
Shoulder dystocia	422
Breech birth	426
Postnatal	429
Secondary postpartum haemorrhage	429
Mastitis or breast abscess	431
Postnatal check	434

7. Sexual and reproductive health

Contraception	438
Contraception options	438
Medroxyprogesterone acetate	439
Combined oral contraceptive pill (COCP)	440
Progestogen only pill (POP)	442

Emergency contraception	443
Sexually transmitted infections (STIs)	445
STI and BBV assessment	445
STI/BBV flowchart	451
Chlamydia, gonorrhoea, trichomonas, m. genitalium	452
Bacterial vaginosis	457
Vaginal thrush (candidiasis)	458
Epididymo-orchitis	459
Low abdominal pain in female/person with uterus	462
Anogenital ulcers/lumps	465
Syphilis	468
Genital herpes simplex virus (HSV)	472
Anogenital warts	474
Human immunodeficiency virus (HIV)	476

8. Paediatrics

Paediatric presentation	480
History and physical examination	480
Differential diagnosis	488
Child with fever	489
Child with cough	490
Child with stridor	491
Child with vomiting	492
Child with abdominal pain	493
Respiratory problems	494
Upper respiratory tract infection (URTI)	494
Sore throat	495
Croup	500
Bronchiolitis	503
Pneumonia	506
Pertussis	508
Epiglottitis	510
Post streptococcal diseases	511
Acute post streptococcal glomerulonephritis (APSGN)	511
Acute rheumatic fever (ARF)	515
Ear problems	519
Ear assessment	519
Ear differential diagnosis	521
Acute otitis media (AOM)	523
Otitis media with effusion (OME)	528
Chronic suppurative otitis media (CSOM)	529
Dry perforation	531
Otitis externa (acute)	532
Gastrointestinal problems	535

Gastroenteritis/dehydration	535
Giardiasis	538
Worms	540
Constipation	542
Pyloric stenosis	544
Intussusception	545
Anaemia	546
Urinary tract problems	548
Urinary tract infection (UTI)	548
Bone and joint problems	550
Acutely swollen/painful joint	550
Child protection	551
9. Immunisations	
Immunisations	554
Tetanus immunisation	557
10. Appendices	
Best possible medication history (BPMH)	560
Patient death in absence of medical officer	561
Glasgow Coma Scale/AVPU	562
Injection pain	563
Ventrogluteal injection	564
Abbreviations and acronyms	565
Index	570
References and What's new	https://www.health.qld.gov.au/rrcsu/clinical-manuals

Foreword

Queensland Health

This year Queensland Health launched the Rural and Remote Health and Wellbeing Strategy 2022-2027 (Strategy). This strategy outlines a whole-of-system approach to achieving health equity for rural and remote Queenslanders. The new strategic plan sets out four overarching goals and two partner goals. The 11th edition of the Primary Clinical Care Manual (PCCM) enables the safe delivery of the Strategy's goals.

Equity of health outcomes

The PCCM adapts state, national and international clinical guidelines to address the specific needs of rural and remote Queenslanders. In accordance with the National Health and Medical Research Council (NHMRC), Guidelines for Guidelines, the PCCM sets out comprehensive health management protocols and clinical care guidelines to reduce the burden of disease and prevent chronic conditions. Examples of how the PCCM aims to improve equity of health outcomes for rural and remote Queenslanders, include:

- Aligning with and integrating state-wide initiatives and programs such as Imminent Birth, Safer Baby Bundle and the Sepsis Program.
- Working in partnership with the Antimicrobial stewardship – ensuring communities with high rates of MRSA have appropriate antibiotic treatment.
- Targeting prevention and early recognition and treatment of chronic conditions, such as acute rheumatic fever and acute post streptococcus glomerulonephritis.

Integrated person-centred care and First Nations health equity

Person-centred care is enabled when greater integration across healthcare and other settings is achieved. The PCCM is inclusive and incorporates health equity outcomes by ensuring the voices of the consumer and First Nations' Peoples are included through both consumer and Aboriginal and/or Torres Strait Islander Health Practitioner representation on the editorial committee. This representation is vital to the delivery of comprehensive care.

Strong partnerships

The Royal Flying Doctor Service (Queensland Section) and Queensland Health have continued to forge a strong partnership since the inception of the PCCM in the late 1990's. This partnership has strengthened and grown to include collaborative partnerships with Queensland Ambulance Service, Australian Defence Force and Department of Health and Human Services, Victoria.

Sustainable, skilled and supported workforce

The PCCM supports and enables clinicians with extended authority to use medicines in defined rural hospitals and isolated practice areas, including the practice of Aboriginal and/or Torres Strait Islander Health Practitioners, Authorised Indigenous Health Workers and Rural and Isolated Practice Registered Nurses (RIPRN). This ensures the workforce represents and responds effectively to the varied and diverse needs of people living in rural and remote areas.

I commend the 11th edition of the PCCM for the continued focus on rural and remote Queensland. With its use to guide clinical practice, we are working towards our vision of healthy rural and remote Queenslanders for today and tomorrow.

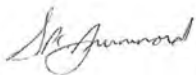

Shaun Drummond
Acting Director-General, Queensland Health

Royal Flying Doctor Service (Queensland section)

Providing the furthest corner with the finest care is no easy feat and is not achieved in isolation. The Royal Flying Doctor Service (Queensland Section) (RFDS) recognises that it is the individual contributions of many that forge strength in the essential health services provided to those that live, work and play in our great state.

The reality is that health service providers across regional, rural and remote communities will always face many challenges, none more emphasised than the 'tyranny of distance.'

With that we see the true value of the Primary Clinical Care Manual (PCCM) for clinicians across Queensland in helping to provide the same standard of care one might expect in a city environment. The PCCM is a readily available, concise reference text in which treating clinicians can trust. Trust knowing that the advice is current, evidence-based and reflective of best practice.

This edition of the PCCM, as per the 10 before it over the past 20 plus years, is very much a shared success story. The RFDS acknowledges the generous sharing of time and expertise by clinical staff, from both Queensland Health and the RFDS, which is essential to the review and revision of each new edition of the manual.



Lee Poole

**Executive General Manager, Nursing & Clinical Services
Royal Flying Doctor Service (Qld Section)**

Australian Defence Force

Defence delivers high quality health care, whether on our bases or when we deploy on military and humanitarian operations. The provision of health care to the men and women of the Australian Defence Force is essential for Defence to perform its role of protecting Australia's national interests. It is important that world class military health services are delivered consistently, no matter where that care is provided.

As Surgeon General of the Australian Defence Force I fully support the evidence-based approach of the Primary Clinical Care Manual (PCCM). Its alignment to National Health and Medical Research Council Guidelines on Clinical Protocols, together with its application to a range of practitioners in isolated and regional settings, make the PCCM a valuable resource for Defence Health Services.

The revised content in this new edition of the PCCM reflects the most up-to-date knowledge compiled by experts in their field. It marks a further improvement upon the high quality of the previous edition. My intent is that the ADF will remain a significant contributor to this excellent publication through representation on the editorial committee to collaboratively maintain this valued resource for Australian Health professionals.

I have endorsed the PCCM for use by health personnel across the Australian Defence Force to support their clinical practice within the Defence health system. The delivery of ready, responsive and resilient military health services is directly enabled by the availability of resources such as this.

It is with great pleasure that I commend to you this 11th edition of the Primary Clinical Care Manual.



Sarah Sharkey, AM, CSC

**Rear Admiral
Surgeon General of the Australian Defence Force**

Queensland Ambulance Service

As the Medical Director of the Queensland Ambulance Service, I enthusiastically endorse the release of the 11th edition of the Primary Clinical Care Manual.

This clinical resource provides evidence-based clinical guidelines and best practice statements that ameliorate the provision of healthcare in rural, remote, and isolated locations. Clinicians face unique geographical challenges and complexities when operating in these resource poor locations and I applaud innovative approaches that address the tyranny of distance. This document unquestionably aids clinical decision-making and ensures patients receive timely, appropriate, and patient-centric care regardless of their location within Queensland.

I would like to acknowledge the work of the editors and editorial committee for producing such a high-quality document and truly believe it will enhance the delivery of healthcare to the broader community.



Professor Stephen Rashford ASM MBBS FACEM
Specialist Emergency Physician and Medical Director
Queensland Ambulance Service

Department of Health and Human Services, Victoria

The Primary Clinical Care Manual (PCCM) 11th edition is a comprehensive resource for Australian rural and remote health professionals. The editorial review committee is made up of multidisciplinary health professionals from across the country and as a nursing leader in Victoria, this resource is invaluable to the provision of healthcare across our state.

Since the commencement of the Victorian Rural and Isolated Practice Registered Nurses (RIPRN) model of care, the provision of a high standard, evidence-based clinical practice for rural and remote communities has significantly improved, demonstrated in the evaluation report published in 2015 outlining the success of the Victorian RIPRN model of care. There are now close to 100 Victorian health services and bush nursing centres approved by the Victorian Department of Health to utilise the RIPRN model of care. This is an exceptional achievement and advancement for both the profession of nursing and in the provision of care in our rural and remote communities. I congratulate all RIPRNs in their achievements and for their ongoing contribution in improving rural and remote health care over this last 10 years.

In Victoria, changes have recently been made to improve and safeguard the RIPRN model of care with new legal requirements for RIPRNs that came into effect on 1st February 2022. This followed extensive consultations with the Nursing and Midwifery Board of Australia. This new legal framework requires nurses applying for endorsement as a RIPRN in Victoria to be subject to new Drugs, Poisons and Controlled Substances Regulations 2017, and approval by the Victorian Health Secretary. In conjunction with these new legislative changes for the RIPRN model of care, the Department of Health has determined the PCCM will continue to be the clinical standard for the administration and supply of scheduled medicines and the primary resource for Victorian RIPRNs.

My sincere thanks to all those involved in providing an updated PCCM which will be utilised in rural and remote Victorian health services to facilitate and provide RIPRNs and other clinicians with an extensive and thorough, evidence-based resource to guide their practice and provide safe, reliable and high-quality care that meets the needs of the communities for which they work in.



Adj. Assoc. Professor Tanya Farrell
Acting Chief Nurse and Midwifery Officer
Safer Care Victoria

Acknowledgements

We acknowledge the Traditional Owners of country throughout Australia and recognise their continuing connection to land, waters and culture.
We pay our respects to their Elders past, present and emerging.

Editors

- Susan Muirhead, RN, RM, RIPRN, CNC, Office of Rural and Remote Health, Queensland Health
- Danielle Jess, RN, RM, RIPRN, CNC, Office of Rural and Remote Health, Queensland Health

Assistant editor

- Sean Booth, RN, RIPRN, CNC, Office of Rural and Remote Health, Queensland Health

Editorial support

- Tazz Harding, Program support officer, Office of Rural and Remote Health, Queensland Health

Editorial committee

- Dr Yvonne Doveren (Chair), Medical Lead, Primary Health Care, RFDS Cairns
- Dr Francois Pretorius (Deputy Chair), Chief Medical Officer, Ochre Health, ACRRM Representative
- Lyn Byers, RN, RM, NP, Remote Primary Health Care Manuals (CARPA - Editorial Committee Chair)
- Maree Cummins NP, Nurse Manager, Aeromedical Training & Clinical Resources, RFDS Qld Section
- Adam Hogan, Senior Pharmacist & Team Leader, Atherton Hospital
- Nathan Holdforth, WO1, Command Warrant Officer, Joint Health Command, ADF
- Dr Richard Loizou, CMDR, Royal Australian Navy, ADF
- Michael Maw NP, Director, The Mordun Group and Institute of Education and Training, NSW
- Dr Jacki Mein, Public Health Medical Officer, Communicable Diseases/Sexual Health, TPHS Cairns
- Michelle Mutzelburg, RIPRN Educator, Cunningham Centre
- David Nicholls, Aboriginal and/or Torres Strait Islander Health Practitioner - C, Apunipima Cape York Health Council
- Lachlan Parker, A/Director, Clinical Policy & Innovation, Qld Ambulance Service
- Jason Phieler, RIPRN, Acute NUM, COVID-19 Clinical Lead, Lorne Community Hospital, VIC
- Josh Stafford, RIPRN, DON, Lockhart River Primary Health Care Centre
- Alecia Staines, Consumer Representative, Health Consumers Qld

Proxy committee representatives

- Janelle Dockray, Senior Outreach Pharmacist, Thursday Island Hospital
- Chloe Mins, Clinical Pharmacist, Thursday Island Hospital
- Bonnie Grant, Senior Pharmacist, Weipa Integrated Health Service
- Trish Heinrich, Quality Manager, Nhill Acute Ward, West Wimmera Health Service, VIC

Clinical reviewers

- The *Primary Clinical Care Manual* editorial committee gratefully acknowledges the contribution of expert clinicians, end users and other stakeholders who participated in the review and development of the 11th edition

Section 1. Patient assessment and transport

- Kerri O'Connor, NUM, Maternal Child Youth Health, NWHHS
- Dr Paul Butel, MO, RFDS Mt Isa, SMO/Consultant, ED Logan Hospital
- Maree Cummins, NP, Nurse Manager, Aeromedical Training & Clinical Resources, RFDS Qld Section
- Retrieval Services Qld, Aeromedical Retrieval & Disaster Management Branch
- Dr Charles Ellis-Hallett, Medical Lead, Primary Health Care, Charleville Base, RFDS Qld Section

Section 2. Pain, nausea and vomiting

- A/Prof Deepak Doshi, Chief Medical Officer, WMHHS
- Dr Chathu Herath, Specialist Paediatrician, Gladstone Hospital
- A/Prof Luke Lawton, Director of Emergency Medicine, TUH, JCU College of Medicine & Dentistry
- Melanie Price, NP, Capella Primary Healthcare Centre, CQHHS
- Dr Isaac Hohaia, Director of Medical Services South Burnett, Rural Health and Aged Care, DDH

Section 3. Emergency

- A/Prof Ulrich Orda, Director of Emergency, Mt Isa Hospital, Adjunct A/Prof JCU
- Dr Paul Butel, MO, RFDS Mt Isa, SMO/Consultant, ED Logan Hospital
- Bronwen Burr, Nurse Educator, Nursing & Midwifery Education Team, TCHHS
- Melanie Price, NP, Capella Primary Healthcare Centre, CQHHS
- Dr Richard Loizou, CMDR, Royal Australian Navy, ADF
- Dr Christa Bell, Emergency Physician and Paediatrician, Children's ED, GCUH & Robina Hospital
- Maree Cummins, NP, Nurse Manager, Aeromedical Training & Clinical Resources, RFDS Qld Section
- Michael Maw, NP, Director, The Mordun Group and Institute of Education and Training, NSW
- A/Prof Luke Lawton, Director of Emergency Medicine, TUH, JCU College of Medicine & Dentistry
- Qld Paediatric Sepsis Program:
 - Kate Weller, Manager
 - Dr Adam Irwin, Medical Co-Chair
 - Dr Paula Lister, Medical Co-Chair
- Dr Julia Clark, Paediatric Infection Specialist, Qld Children's Hospital
- Dr Paul Lane, A/Director Patient Safety, Safety and Quality Unit, TPCH
- Vikrant Kalke, Principal Project Officer, Qld Sepsis Program
- Richard Smith, NP, Marie Rose Centre, North Stradbroke Island
- Dr Fahid Hashem, Staff Specialist, Endocrinology & General Medicine, GCUH
- Dr Robert Gluer, Director of Cardiology, Toowoomba Base Hospital
- Emily Brownlee, Clinical Research Nurse, RN, Emergency & Trauma Centre, RBWH
- Laura Stephensen, RIPRN, A/Nurse Researcher, Emergency & Trauma Centre, RBWH
- A/Prof Andrew Wong, Director Neurology and Stroke, RBWH, UQ Faculty of Medicine
- Dr Graeme Maw, Senior Staff Specialist, Emergency Department, TUH
- Michael Handy, A/Director of Trauma & Orthopaedics, RBWH
- Dr Elizabeth Vujchick, General Burns and Trauma Surgeon, RBWH
- Dr Stephen Johnston, GPwSI ENT, TCHHS Ear Nose & Throat Service, Weipa Hospital
- A/Prof Bernard Whitfield, Director OHNS, Division of Surgery, Logan & Beaudesert Health Service
- Anette Smith, A/CNC, Clinical Coordination Hub, ENT Outreach Service, TCHHS
- Dr Adam Holyoak, Medical Superintendent, Thursday Island Hospital

- Dr Isaac Hohaia, Director of Medical Services, Sth Burnett, Rural Health & Aged Care, DDH
- Wendy Cannon, RIPRN, DON, Chillagoe PHCC
- Prof Michael Muller, Burns Trauma General Surgery, RBWH
- A/Prof Daniel Carroll, Senior Staff Specialist, Dept of Paediatric Surgery, TUH
- Dr Katina Breeze, Senior Staff Specialist, QCH ED
- Dr Clinton Gibbs, Clinical Director (North), Retrieval Services Qld
- Dr Preety George, Medical Officer, RFDS Cairns
- Dr Andrea Miller, Rural Generalist, Adult Internal Medicine/Renal, Cape York Kidney Care
- Dr Erik Wood, A/Deputy Director, ED Redcliffe Hospital
- Carol Wylie, Pharmacist Consultant, Manager, Qld Poisons Information Centre, QCH
- Nimrata Kaur, RN, MN, Clinical Specialist, Intraosseous & Vascular Access, Teleflex Medical Australia & NZ
- Child Protection & Forensic Medical Services, QCH:
 - Renae Majcen, Program Manager
 - Dr Emma-Jane Roper, Senior Medical Officer
- Dr Les Griffiths, Forensic Medical Officer, Clinical Forensic Medical Unit, Qld Health
- Rachael Brown, Principal Program Officer, Child and Family Services, Dept. of Children, Youth Justice and Multicultural Affairs
- Jos Middleton, Manager, Far North Mental Health, RFDS Qld Section
- Elizabeth Morter, Manager, Cairns Sexual Assault Service (Adult), True Relationships, Cairns

Section 4. General

- Dr Peter Osborne, Director Oral Health Services, Office of the Chief Dental Officer, CEQ
- Dr Katherine Lewis, Principal Dentist, Oral Health, Sunshine Coast Hospital
- Professor Hugh Taylor, AC, Indigenous Eye Health Unit, University of Melbourne
- Shelley Walters, CNC Ophthalmology, Primary Health Care, Thursday Island Hospital
- School of Optometry & Vision Science, Faculty of Health; Centre for Vision and Eye Research, QUT:
 - Dr Shelley Hopkins, BOptom, PhD
 - Dr Emily Pieterse, BAppSc (Optom), BApp Sc (Med Sc), Grad Cert (Oc Ther), PhD
- Epidemiology & Research Unit, Communicable Diseases Branch, Department of Health Qld
- Roslyn Everett, RIPRN, Stanthorpe Qld
- Dr Adam Holyoak, Medical Superintendent, Thursday Island Hospital
- Dr Louise Craig, Executive Clinical services, Apunipima Cape York Health Council
- Dr Lara Wieland, SMO TCHHS, SMO Apunipima Cape York Health Council
- Dr Emma Wawn, Emergency Physician, Director Hospital in the Home, TUH
- Sara Noonan, Technical Advisor, RHD Australia, Menzies School of Health Research, Darwin
- RHD Register and Control Program, Qld:
 - Kylie McKenna, Manager
 - Georgina Hughes, CNC
 - Louise Axford-Haines, CNC
- Benjamin Ward, Senior Podiatrist, Cairns High Risk Foot Team, Cairns Diabetes Centre
- Jessica Anderson, Inpatient Podiatrist, Diabetic Foot Disease Inpatient Coordinator, Cairns Diabetes Centre
- Jennifer Tidboald, CN, Wound Management/Stomal Therapy Dept, CHHS
- Kerri O'Connor, NUM, Maternal child Youth Health, NWHHS

- Carol Wylie, Pharmacist Consultant, Manager, Qld Poisons Information Centre, QCH
- David Nicholls, Aboriginal and/or Torres Strait Islander Health Practitioner - C, Apunipima Cape York Health Council
- Josslyn Tully, Manager Health Worker Service, TCHHS Indigenous Health
- Dr Richard Gair, Director of Cairns PHU, Tropical Public Health Service Cairns
- Dr Annie Preston-Thomas, PHU Medical Officer, Tropical Public Health Service Cairns
- Juliet Esmonde, Public Health Nurse, Communicable Disease Control Cairns

Section 5. Mental health and alcohol withdrawal

- Dr Matthew Coates, Consultant Psychiatrist, Staff Specialist Mental Health, Mental Health & ATODS, Cooktown & Thursday Island
- Dr Manoj George, Consultant Psychiatrist & Psychogeriatrician, Clinical Lead for Older Person's Mental Health, Ipswich Hospital
- Stephen Lewis, NP, Community Mental Health, DDHHS
- Janet Martin, Director Clinical Governance, Office of the Chief Psychiatrist Mental Health Alcohol & Other Drugs Branch, CEQ

Section 6. Obstetric and neonatal

- Joanne Leamy, Clinical Coordinator, Sexual Health, TCHHS
- Cecily Labuschewski, CN Women's Health, Cherbourg Hospital
- Sharon Young, NP, Mobile Sexual & Women's Health, SWHHS
- Sue McPherson, NP, Midwife, Women's Health Unit, MHHS
- Audra Davis, CMC, Maternity Project Officer, THHS
- A/Prof Greg Duncombe, Discipline of Obstetrics and Gynaecology, Faculty of Medicine, UQ, Clinical Director of Maternal Fetal Medicine, SCUH
- Rukhsana Aziz, CMC, WMHHS
- Rhonda Taylor, RN, M, MMid, CMC, Birth Suite/Birth Centre, TUH
- QuMid Project, Retrieval Services Qld:
 - Meredith Lovegrove, CMC
 - Justine Powell, CMC
 - Anita Parnemann, CMC
 - Deb Fifield, CMC
- Dr Christopher King, Senior Specialist, Clinical Director, Dept Obstetrics & Gynaecology, NWHHS
- A/Prof Thangeswaran Rudra, Senior Staff Specialist, RBWH, Academic Lead, University of Qld
- Lesley Mallard, Nurse Manager, Cairns Primary Health Care, RFDS Qld Section
- Dr Saliya Ovitigalage, Staff Specialist, Obstetrics & Gynaecology, Hervey Bay & Maryborough Hospitals
- Megan Benson, Midwifery Nurse Educator, Learning & Development, SWHHS
- Yolande Thomas, Midwifery Nurse Educator, Learning & Development, SWHHS
- Christine Latimer, CNC, Neonatal Retrievals ANTS-NQ, TUH
- Dr Susan Ireland, Staff Specialist, Neonatal, Neonatal Unit, TUH
- Donna Hovey, RN, CWHHS
- Lynette Chapple, A/CNC, Neonatal Retrievals, Neonatal Unit, TUH
- Cheryl-Anne Murphy, RN, Midwife, Redcliffe Hospital
- Jeanette Tyler, CN, Midwifery Consultant, RBWH
- Kristina Palmer-Field, CN, Midwifery Consultant - Lactation, RBWH

- Claire Harper, Midwifery Group Practice Midwife, RBWH
- Dr Kirsty Devine, Staff Specialist, Neonatal, TUH

Section 7. Sexual and reproductive health

- Dr Amanda Blinco, Regional Medical Officer, True Relationships and Reproductive Health
- Joanne Leamy, Clinical Coordinator, Sexual Health, TCHHS
- Dr Darren Russell, Director of Sexual Health, Cairns Sexual Health Service
- Therese Howard, Public Health Nurse, Qld Syphilis Surveillance Service, Tropical Public Health Service Cairns
- Dr Jacki Mein, Public Health Medical Officer, Communicable Diseases/Sexual Health, TPHS Cairns
- Dale Thompson, NP, Mt Isa Sexual Health, NWHHS
- Karen Brown, Nurse Educator, Nursing & Midwifery Education Team, DDH
- Fiona McFarlane, Public Health Nurse - Sexual Health/COVID-19, TPHS Cairns
- Sharon Young, Mobile Sexual & Women's Health Nurse Practitioner, SWHHS
- Katie Edmondson, CNC, Contact Tracing Support, Townsville Sexual Health Service
- Penny Kenchington, NP, Townsville Sexual Health Service
- Colette Cashman, Public Health Nurse - HIV, Tropical Public Health Service Cairns
- Suzanne Connor, Public Health Nurse, Tropical Public Health Service Cairns
- Lucy Thallon, Public Health Nurse, Tropical Public Health Service Cairns
- Australasian Society for HIV, Viral Hepatitis and Sexual Health Medicine (ASHM)

Section 8. Paediatrics

- Dr Stephen Johnston, GPwSI ENT, TCHHS Ear Nose & Throat Service, Weipa Hospital
- A/Prof Bernard Whitfield, Director OHNS, Division of Surgery, Logan & Beaudesert Health Service
- Anette Smith, A/CNC, Clinical Coordination Hub, ENT Outreach Service, TCHHS
- Deadly Ears Program:
 - Matthew Brown, Director
 - Rosie Borey, A/CNC
 - Amanda Wood, CNC
- Dr Venkatesh Aithal, Director & Consultant Audiologist, Audiology Dept, TUH, Adjunct Senior Lecturer, UQ
- Dr Chathu Herath, Specialist Paediatrician, Gladstone Hospital
- Kerri O'Connor, NUM, Maternal Child Youth Health, NWHHS
- Dr Andrew White, Clinical Director, Paediatrics, TUH, A/Prof JCU
- Dr Lara Wieland, SMO TCHHS, SMO Apunipima Cape York Health Council
- Wendy Cannon, RIPRN, DON, Chillagoe PHCC
- A/Prof Deepak Doshi, Chief Medical Officer, WMHHS
- Dr Helen Pedgrift, Public Health Registrar, Tropical Public Health Service
- Dr Andrea Miller, Rural Generalist - Adult Internal Medicine/Renal, Cape York Kidney Care, TCHHS
- Sara Noonan, Technical Advisor, RDH Australia, Menzies School of Health Research, Darwin
- RHD Register and Control Program, Qld:
 - Kylie McKenna, Manager
 - Georgina Hughes, CNC
 - Louise Axford-Haines, CNC
- Raeleigh Bryant, CYMHS Director Occupational Therapy, CHQHHS

- Child Protection & Forensic Medical Services, QCH:
 - Renae Majcen, Program Manager
 - Dr Emma-Jane Roper, Senior Medical Officer
- Rachael Brown, Principal Program Officer, Child and Family Services, Dept. of Children, Youth Justice and Multicultural Affairs

Section 9. Immunisations

- Ann Richards, Public Health Manager, South, TCHHS
- Joanne Leamy, Clinical Coordinator, Sexual Health, TCHHS
- Marita Box, RN, RM, Grad Dip Child Family & Community Health
- Susan Muirhead, RN, RM, RIPRN, CNC, Office of Rural and Remote Health, Queensland Health
- Danielle Jess, RN, RM, RIPRN, CNC, Office of Rural and Remote Health, Queensland Health

Section 10. Appendices

- Adam Hogan, Senior Pharmacist & Team Leader, Atherton Hospital
- Josh Stafford, RIPRN, DON, Lockhart River PHCC
- Sara Noonan, Technical Advisor, RHD Australia, Menzies School of Health Research, Darwin
- RHD Register and Control Program, Qld:
 - Kylie McKenna, Manager
 - Georgina Hughes, CNC
 - Louise Axford-Haines, CNC

Queensland Statewide Antimicrobial Stewardship Program

- Dr Kathryn Daveson, A/Director
- Dr Trent Yarwood, Director
- Stephen Nocher, CNC
- Dr Kevin O'Callaghan, Staff Specialist
- Nicolette Graham, Clinical Pharmacist Lead, Paediatrics
- Dion Zunker, Senior Pharmacist

End user working group

- Richard Smith, NP, Marie Rose Centre, North Stradbroke Island
- Laura Stephensen, RIPRN, A/Nurse Researcher, Emergency & Trauma Centre, RBWH
- Nicci Maher, RIPRN, DON, Facility Manager, Eidsvold MPHS
- Colleen Murphy, District Clinical Nurse Educator, Longreach Hospital
- Karen Cooke, RIPRN, DON, Facility Manager, Nanango Hospital
- Janet Jerram, RN, RIPRN, Gympie Hospital
- Debbie McConnel, Nurse Educator, General & Maternity, Proserpine Hospital
- Loren McIlroy, Flight Nurse (Midwifery), RFDS Qld Section
- Scott Windsor, RIPRN, A/DON, Burketown PHCC
- Travis Cole, Nurse Educator - Emergency, TUH
- Lear Langley, RIPRN, CN, Gin Gin Hospital
- Roslyn Everett, RIPRN, Stanthorpe, Qld

Introduction

The Primary Clinical Care Manual (PCCM) supports and enables rural, remote and isolated clinicians to provide evidence-based, quality and safe care for people living in these areas. The PCCM has been developed and reviewed according to principles of the National Health and Medical Research Council's guideline development

The PCCM and collaborative practice

- The PCCM promotes a collaborative approach to patient care. The collaborative practice relationship incorporates the dual notions of collaboration and delegation
- The defining characteristics of the collaborative practice relationship using the PCCM in the rural and isolated context are:
 - mutual respect and acknowledgement of each profession's role, scope of practice and unique contribution to health outcomes
 - clear protocols and guidelines for clinical decision making that comply with relevant legislation and are supported by the health facility and the health organisation
 - clearly defined levels of accountability with an acceptance that joint clinical decision making is an integral component of collaborative practice
 - a belief that the best health outcomes are achieved when well prepared health professionals work in collaboration and partnership in both practice and educational settings

Recognising and responding to acute deterioration

- The PCCM supports the use of Early Warning and Response System (EWARS) tools. In Queensland, use age and patient appropriate **rural and remote** EWARS tools as per local policy:
 - Q-ADDS - adult
 - MEWT - maternity
 - CEWT - paediatric
 - NEWT - neonatal (≤ 28 days old)
- In jurisdictions outside of Queensland use local EWARS tools

Endorsing the PCCM in Queensland

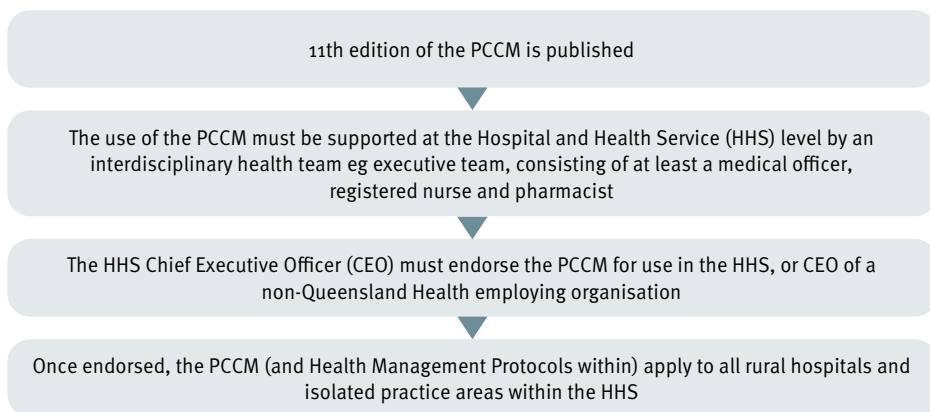

Authority to administer and supply medicines

- Authority for clinicians to administer and supply medicines is provided by the medicines and poisons law within the state or territory of practice. Clinicians are advised to familiarise themselves with the relevant legislation, check for updates/changes and adhere to local policies for using medicines
 - The legislation provides definitions and conditions related to a person's authority to use medicines (eg administer, supply, give a treatment dose, rural hospital, isolated practice area)
 - Clinicians must practice within their individual scope and in accordance with conditions and circumstances of practice relevant to their authority
- **RN supplying** - S2 or S3 (Qld). RNs are authorised to **administer** (give a single dose to take immediately) any S2 or S3 medicines without an order. To **supply** (give 1 or more doses to be taken at a later time) a medicine at a defined rural hospital or isolated practice area, an RN is required to obtain an order, plus meet requirements in Schedule 7, Part 3, Division 4 of the *Medicines and Poisons (Medicines) Regulation 2021* <https://www.legislation.qld.gov.au/view/whole/html/inforce/current/sl-2021-0140>
 - **RIPRN supplying** - RIPRNs (Qld) are authorised to **administer and supply** any S2 or S3 medicine without an order or supporting HMP. This includes S2 and S3 medicines not included in the PCCM

Clinicians with extended authority to use medicines

Queensland - extended practice authority (EPA)

- The PCCM contains Health Management Protocols to support the expanded practice of clinicians practicing under an 'extended practice authority' (EPA) in defined rural hospitals and isolated practice areas, including:
 - Registered nurses (RN):
 - part A - if the RN in the rural hospital or isolated practice area has a document stating their credentialed scope of clinical practice to perform a 'specified service' that is approved by the Hospital and Health Service the RN works for
 - part B - Rural and Isolated Practice Registered Nurse (RIPRN)
 - part C - Sexual or Reproductive Health (SRH)
 - part D - Immunisation Program Nurse (IPN)
 - Midwives (MID)
 - Aboriginal and Torres Strait Islander Health Practitioners (ATSIHP)
 - Authorised Indigenous Health Workers (IHW)
 - Queensland Ambulance Service - Isolated Practice Area Paramedics (IPAP)
- Refer to each EPA for conditions and circumstances of practice under that EPA. See <https://www.health.qld.gov.au/system-governance/licences/medicines-poisons/medicines-poisons-act/legislation-standards>

Victoria - RIPRNs

- The PCCM supports the practice of Rural and Isolated Practice Registered Nurses (RIPRN) in Victoria
- An RN (without RIPRN) must adhere to the relevant medicines legislation in Victoria
- For more information see <https://www.health.vic.gov.au/rural-health/rural-and-isolated-practice-endorsed-registered-nurse>

Australian Defence Force (ADF)

- The PCCM supports practice of AHPRA registered health service personnel within the ADF
- For more information, refer to the Defence Health Manual and approved Service extended practice authorities to supply, carry and administer medications

Other states or territories

- If practicing elsewhere, clinicians are still able to use the PCCM if their employer authorises them to do so. Clinicians must be familiar with the relevant state and territory medicines and poisons legislation and ensure they practice within their legal authority

Health Management Protocols and Clinical Care Guidelines

- Each topic in the PCCM is either a Health Management Protocol (HMP) or a Clinical Care Guideline (CCG)
- HMPs are required for clinicians who are practicing with an extended practice authority in Queensland. They are the same as a CCG, but also include a **drug (medicine) box** providing details of the medicine authorised to be administered or supplied

Example of HMP in topic title

- HMPs are easily identified with the letters HMP in the topic title. CCGs are all other topics

Example of a Health Management Protocol - **HMP in title**

HMP Anaphylaxis - adult/child

Example of a Clinical Care Guideline - **no HMP in title**

Drowning/submersion - adult/child

Drug (medicine) boxes

- Instructions in drug (medicine) boxes advising authorities of clinicians, eg proceed or consult a medical officer (MO) or nurse practitioner (NP), are **based on Queensland authorisation to use medicines**
- The boxes are not intended to contain all information required for safe administration or supply of the medicine
- Clinicians should:
 - refer to the current *Australian Medicines Handbook (AMH)* or other adult or paediatric pharmacology resource prior to using medicines for additional information such as adverse effects, interactions and contraindications
 - be aware of contraindications and known side effects and advise the patient accordingly
 - source additional consumer medicine information (CMI) as relevant eg <https://www.nps.org.au/medicine-finder>
 - practice within their individual scope
 - consult MO, NP or pharmacist as needed
 - adhere to local policies and any other legislative requirements in regards to medicines
- **Schedules of medicines (S2, S3, S4, S8)** are located in the top left corner of each drug (medicine) box. These are according to the current Standard for Uniform Scheduling of Medicines and Poisons <https://www.tga.gov.au/publication/poisons-standard-susmp>

Drug (medicine) box examples

Example 1 - extended authority in Queensland (Qld)

- Always located within an HMP. Identifies which clinicians have extended authority (in Qld) and details if the clinician can proceed or requires an order
- **Note:** does not include Qld RNs with authority under Part A of the RN EPA. This will be determined by their individual documented credentialed scope of practice

Queensland clinicians who have extended authority identified here
Note abbreviations:

- **ATSIHP** - Aboriginal and Torres Strait Islander Health Practitioner
- **IHW** - Authorised Indigenous Health Worker
- **IPAP** - Isolated Practice Area Paramedic
- **MID** - Midwife
- **RIPRN** - Rural and Isolated Practice RN
- **SRH** - Sexual or Reproductive Health RN
- **IPN** - Immunisation Program RN

Clinicians are advised if they are required to obtain an order or are authorised to proceed without an order

S ₄	Metronidazole			Extended authority	
				ATSIHP/IHW/IPAP/RIPRN/SRH	
ATSIHP, IHW, IPAP and RN must consult MO/NP					
RIPRN and SRH may proceed					
Form	Strength	Route	Dose	Duration	
Tablet	200 mg, 400 mg	Oral	400 mg bd	7 days	
Offer CMI: Avoid alcohol for 24 hours after taking. Take with food to reduce stomach upset. May cause nausea, anorexia, abdominal pain, vomiting, diarrhoea, metallic taste, dizziness or headache					
Pregnancy: Safe to use. Give in divided doses if possible					
Management of associated emergency: Consult MO/NP					

Example 2 - unscheduled medicine

- Not related to an extended authority. An order may or may not be required

Queensland clinicians are advised if they are required to obtain an order or are authorised to proceed without an order

Left blank

Unscheduled	Thiamine				
ATSIHP, IHW, IPAP, RIPRN and RN may proceed					
Form	Strength	Route	Dose	Duration	
Injection	300 mg/3 mL	IM	Adult 300 mg	stat	
Note: Give thiamine before administering glucose for hypoglycaemia. Giving glucose in thiamine deficiency may precipitate Wernicke encephalopathy					
Management of associated emergency: Consult MO/NP					

Example 3 - prescribing guide

- Not related to an extended authority

Must be ordered by an authorised prescriber.
Only to be administered by clinicians who are authorised to administer medicines on an order as per usual scope of their profession eg RN, midwife

Prescribing guide identified

Unscheduled	Calcium gluconate			Prescribing guide
RIPRN and RN only. Must be ordered by an MO				
Form	Strength	Route	Dose	Duration
Injection	2.2 mmol/10 mL	IV	Adult 30 mL Child 0.6 mL/kg (max. 30 mL)	stat Inject slowly over 5–10 minutes in a large peripheral vein
Offer CMI: To neutralise effects of hydrofluoric acid				
Note: High-risk medicine and is rapidly fatal in overdose. Extravasation can cause tissue necrosis				
Contraindication: Subcut and IM route				
Management of associated emergency: Consult MO/NP				

Patient assessment and transport

Patient presentation - adult and child

General principles¹

- The first priority is to assess whether the patient is seriously ill and needs immediate management, or is less acutely sick giving time to get a full history
- Always ask open questions
- In children, pay particular attention to history from parent/carer where available

Rapid assessment

- **D**anger
- **R**esponse
- **S**end for help if unresponsive
- **A**irway - compromised
- **B**reathing - not breathing, significant respiratory distress
- **C**irculation - pulse absent, slow, rapid or profuse bleeding
- **D**isability - **A**lert, **V**oice, **P**ain, **U**nresponsive
- Rapid history, allergies
- Vital signs - RR, SpO₂, HR, BP, T - use appropriate Q-ADDS/CEWT/MEWT (Qld) or local EWARS
- Consider BGL

Any COVID-19 signs/symptoms

- For the latest information on infection control, testing and management refer to **local policy, or** <http://disease-control.health.qld.gov.au/condition/837/2019-ncov> (Qld) or your state/territory guidelines
- Also see *Australian guidelines for the clinical care of people with COVID-19* <https://covid19evidence.net.au/#living-guidelines>

Is patient immediately at risk

Yes

Perform immediate stabilising or life saving measures. See [Basic life support, p. 46](#) [Advanced life support, p. 48](#) Or other topic relevant to urgent presentation

Consult MO/NP as soon as circumstances allow

No

Note: if trauma related eg fall/hit by an object/motor vehicle accident, promptly assess against [Criteria for early notification of trauma for interfacility transfer \(inside front cover\)](#)

If meets criteria contact ☎ RSQ 1300 799 127 or RFDS 1300 697 337

If outside Qld, refer to local early notification process

Get history and do physical examination as relevant. See [History and physical examination - adult, p. 17](#) or [History and physical examination - child, p. 480](#)

Form a clinical impression

Select appropriate topic to guide further assessment and management

Adult presentation

History and physical examination - adult

Recommend

- If child, see [History and physical examination - child, p. 480](#)
- Ensure a culturally safe environment. As appropriate, be guided by local health workers
- Document your findings clearly, concisely and in logical sequence - use this section to assist
- Offer opportunistic health promotion, screening and brief intervention for lifestyle modification(s) during visit as appropriate.^{1,2} For screening tools and checks, see the *Chronic conditions manual* <https://www.health.qld.gov.au/rrcsu/clinical-manuals/chronic-conditions-manual-ccm>

Background

- The history is the most powerful tool for identifying the likely diagnosis in most cases¹
- Types of history:²
 - **complete** - comprehensive history of the patient's past and present health status. Usually done at initial visit in a non-emergency situation
 - **focused/problem centred** - shorter and specific to the patient's current presenting concern
 - **follow up** - evaluation of problem from preceding visit
 - **emergency** - urgent, rapid collection of crucial information compiled concurrently with life-threatening measures. Take a comprehensive history once patient is stabilised

Related topics

[History and physical examination - child, p. 480](#)
[Mental health emergency, p. 336](#)

[STI/BBV assessment, p. 445](#)
[Traumatic injuries, p. 134](#)

Vital signs - adult approximate normal values^{1,2}

Temperature (T) (oral, tympanic) ³	35.5–37.5
Heart rate (HR)	60–100 beats/minute
Respiration rate (RR)	12–20 breaths/minute
Blood pressure (BP)	Systolic < 130, diastolic < 85
O ₂ saturation (SpO ₂) ⁴	≥ 94%
Conscious level (Alert, Voice, Pain, Unresponsive)	Alert
Capillary refill time (CRT) ³	≤ 2 seconds
Blood glucose level (BGL) ⁵	4.0–7.8

Step 1: Obtain history of the presenting concern/problem^{1,6}

- Taking the history is the first step in making a diagnosis
- Use the history to guide the physical examination/further investigations
- An accurately acquired history will usually suggest the diagnosis. The physical examination and investigations should be used to confirm your diagnostic impression

History of the presenting concern/problem^{1,6}	
Presenting concern/ problem	<ul style="list-style-type: none"> • Ask what the problem is • Use open ended questioning
<p>For each symptom ask about (as relevant)</p> <p>Use SOCRATES mnemonic</p>	<ul style="list-style-type: none"> • Ask about length of illness and details of each symptom(s) • Site - where is the symptom - localised or diffuse • Onset: <ul style="list-style-type: none"> – gradual, rapid or sudden – continuous or intermittent – what were they doing when it started • Character eg if pain: <ul style="list-style-type: none"> – sharp, dull, burning, stabbing, cramp like, crushing, tingling • Radiation - (if localised) does it travel elsewhere • Alleviating factors - does anything make it better eg sitting up, medicine(s), analgesia • Timing: <ul style="list-style-type: none"> – when did it first begin, duration – have they had it before – any increase in severity • Exacerbating factors - does anything make it worse eg movement, exercise • Severity: <ul style="list-style-type: none"> – does it interfere with sleep or normal activities – if pain - mild, moderate or severe OR severity on scale of 1–10
Associated/other symptoms	<ul style="list-style-type: none"> • eg nausea, vomiting, photophobia, headache, appetite, urine, bowels, energy • Ask specifically about fever, pain, shortness of breath (SOB), diarrhoea, weight loss
Treatment ± medicine(s) taken during this illness	<ul style="list-style-type: none"> • What, how much, when, how often, effectiveness
<ul style="list-style-type: none"> • Ask if there are any other concerns • Consider possible differential diagnosis • Subsequently use closed ended questions to confirm or refute your differential diagnoses 	

Step 2: Ask about past history^{1,6}

- Review and update past history in medical record each visit. As appropriate, check *My Health Record* <https://www.myhealthrecord.gov.au>
- Consider past history that may assist with differential diagnosis this visit
- Always ask about allergies and medicines

Past history ^{1,6}	
Past medical and surgical history	<ul style="list-style-type: none"> • Significant illnesses in the past • Ask about - diabetes, hypertension, angina and heart attacks, epilepsy, asthma, mood, mental health problems • Previous hospital admissions, operations or injuries - where, when, why • Is patient immunocompromised eg:⁷ <ul style="list-style-type: none"> – diabetes, chronic kidney disease or hepatitis, alcoholism, malnutrition, liver failure, cancer, no spleen, lupus, multiple sclerosis, rheumatoid arthritis, HIV, Down syndrome, corticosteroids, chemotherapy
Family history	<ul style="list-style-type: none"> • Health problems in siblings and parents eg diabetes, hypertension, heart disease, stroke, epilepsy, asthma, cancer, mental health
Social history	<ul style="list-style-type: none"> • Usual GP + contact details if available • Job, living conditions, who else lives at home and what responsibilities do they have in the family. Means of communication for contact/follow up eg phone • Who their partner is or if they are in a relationship • Gender identification and pronouns patient identifies with eg her/him • Smoking/ever smoked - how many a day, ever tried giving up; e-cigarette use • Alcohol - what, how much + often. Express in standard drinks per day or week • Recreational drugs • Recent overseas travel (if infectious disease possible) - where/when • Diet, exercise
Medicines Also see Best possible medication history, p. 560	<ul style="list-style-type: none"> • Regular and prn medicines - prescribed/over-the-counter, complementary, alternative, bush medicines, vitamins, oral/other contraceptive (females): <ul style="list-style-type: none"> – generic name, dose, route, frequency – explore adherence and any barriers to taking medicines as prescribed – recently changed/course completed • If patient has medicines with them, check against medical record
Allergies Adverse medication reactions	<ul style="list-style-type: none"> • Allergies/reactions + type of reaction (anaphylaxis, skin reaction, other) to: <ul style="list-style-type: none"> – medicines – other eg honey bee stings, sticking plaster, food – is adrenaline (epinephrine) autoinjector used eg EpiPen® • Check medical record + document allergies/adverse reactions⁹ • Check medic alert jewellery/accessories eg key ring, USB, shoe tag, anklet, watch, tattoo⁸
Immunisations	<ul style="list-style-type: none"> • Check if up-to-date, including COVID-19 vaccination status • Offer opportunistic Immunisations, p. 554 as appropriate
Opportunistic health checks (offer or refer as appropriate)	<ul style="list-style-type: none"> • Check if due for routine health checks eg STI/BBV tests, p. 448, Cervical Screening Test, mammogram, bowel screening • See the <i>Chronic conditions manual</i> https://www.health.qld.gov.au/rccsu/clinical-manuals/chronic-conditions-manual-ccm for adult health checks

Step 3: Do physical examination^{1,6}

- Most information will be gained from history taking. Use this information to guide examination
- **In an adult who is not sick:**
 - examine the relevant system first
 - proceed to further examination if required. Be guided by your findings
- **In a sick adult:**
 - examine the relevant system first followed by ALL other systems
- Use a systematic approach to physical examination

Physical examination - adult^{1,6}

Vital signs	<ul style="list-style-type: none"> • RR, HR, BP, T, SpO₂ • Conscious state - GCS/AVPU, p. 562 • If indicated: <ul style="list-style-type: none"> – BGL – capillary refill time (≤ 2 seconds) <p style="text-align: center;">Document on appropriate Q-ADDS (Qld) or local EWARS</p> <p style="text-align: center;">If pregnant/postnatal, use appropriate Q-MEWT rural and remote tool Calculate score. Act on score if indicated</p>
General appearance	<ul style="list-style-type: none"> • Do they look sick/not sick (well) • Observe: <ul style="list-style-type: none"> – posture, mobility – any ↑ work of breathing (WOB), breathlessness – conjunctiva and nail beds - are they pale – lips, tongue and fingers - are they blue – general skin colour - pale/jaundiced – agitation, distressed – body/breath odours – sweating – are they well nourished • Weight ± height, BMI and waist measurement
Hydration	<ul style="list-style-type: none"> • Eyes - normal or sunken • Mouth and tongue - wet or dry • Skin turgor - normal or reduced. Pinch skin - normal skin returns immediately on release (normal can be reduced in elderly) • Dry axillae • Recent weight loss/gain

Physical examination - adult^{1,6}(continued)

Skin	<ul style="list-style-type: none"> • Check the whole body in a sick patient: <ul style="list-style-type: none"> – consider removing clothing to underwear • Look for: <ul style="list-style-type: none"> – rashes - vesicular, macular, papular, petechiae, purpura – signs of infection - redness, swelling, tenderness – bruising, unexplained or unusual marks – general pigmentation - areas where skin is lighter or darker • Any skin lesions or sores: <ul style="list-style-type: none"> – colour, shape, size, location, distribution on body – non-blanching – vesicles present – exudate eg clear, pus, bloody – any family members/close contacts with similar lesions • Palpate/feel skin: <ul style="list-style-type: none"> – temperature, dryness/moisture, clamminess – any tender/enlarged lymph nodes in the neck, axillae or groin
Cardiovascular system	<ul style="list-style-type: none"> • Also see Chest pain assessment, p. 103 • Any: <ul style="list-style-type: none"> – pain/pressure in neck, chest, arms – SOB on exertion – evidence of oedema, particularly feet, hands, face or sacrum • Check skin: <ul style="list-style-type: none"> – colour - pink, white, grey, mottling. Compare trunk with limbs – temperature - hot, warm, cool or cold. Compare trunk with limbs • Central perfusion - blanch skin over the sternum with your thumb for 5 seconds. Time how long it takes the colour to return • Peripheral perfusion - blanch the skin on a finger or toe for 5 seconds. Time how long it takes for the colour to return • Look for distended neck veins • If trained in auscultation listen to heart sounds
Respiratory system	<ul style="list-style-type: none"> • Most information is gained from simple observation • Inspect anterior/posterior chest - equal chest expansion, abnormal chest movement, ↑ WOB, use of accessory muscles, tracheal tug • Can they talk in full sentences, single words or unable to talk at all • Measure RR over 1 minute - note rhythm, depth and effort of breathing • Listen for extra noises - cough (loose, dry, muffled ± sputum), wheeze, stridor, hoarseness • Auscultate for air entry into both lung fields: <ul style="list-style-type: none"> – equal, adequate – any wheeze or crackles - on inspiration or expiration • Percuss lung fields - dull, resonant, hyper-resonant • Can they lie flat without breathlessness

Physical examination - adult^{1,6}(continued)

<p>Gastrointestinal/ reproductive system</p> <p>Consider cultural safety/sensitivity</p>	<ul style="list-style-type: none"> • Inspect abdomen for scars, distension, hernias, bruising, masses • Auscultate bowel sounds in all 4 quadrants - present or absent • Palpate abdomen: <ul style="list-style-type: none"> – soft or firm – obvious masses – tender to touch. Identify abdominal quadrant and exact area – guarding or rigidity even when the patient is relaxed – rebound tenderness - press down and take your hand away very quickly, is pain greater when you do this • Change of bowel habits • Ask women: <ul style="list-style-type: none"> – date of last normal menstrual period – abnormal vaginal bleeding or discharge • Do pregnancy test in females of reproductive age with abdominal pain • In men: <ul style="list-style-type: none"> – if relevant check the testes - any redness, swelling or tenderness – ask about penile discharge • See abdominal examination, p. 197 for detailed assessment
<p>Nervous system</p>	<ul style="list-style-type: none"> • Assess conscious state. See GCS/AVPU, p. 562 • Any dizziness, fainting, blackouts, problems with speech, vision, weakness in arm/leg, altered sensation, neck stiffness • Assess orientation to time, place and person: <ul style="list-style-type: none"> – ask - name, date of birth, location, time, date, year • Check: <ul style="list-style-type: none"> – pupils - size, symmetry, reaction to light – for asymmetry of tone and power - compare each side of the face and limbs – if indicated, test touch and pain sensation - using cotton wool and the sharp end of the percussion hammer – test finger nose coordination and if possible observe the patient walking
<p>Musculoskeletal system</p>	<ul style="list-style-type: none"> • Ask if any painful or stiff joints or muscular pain • Observe gait • Inspect joints for redness, swelling or lacerations over or near a joint
<p>Eyes</p>	<ul style="list-style-type: none"> • As indicated, test the Visual acuity, p. 278 of each eye • Inspect: <ul style="list-style-type: none"> – eyes and surrounding structures - any redness, discharge or swelling – pupils - equal in size, regular in shape, reaction to light – eye movements • See Eye assessment, p. 276 for detailed assessment

Physical examination - adult ^{1,6} (continued)	
Ears, nose and throat	<p>Ears</p> <ul style="list-style-type: none"> Inspect - pinna - any redness, swelling, nodules Any obvious swelling or redness of the ear canal. If there is, looking with an otoscope will be painful Using otoscope, inspect: <ul style="list-style-type: none"> canal - any redness, swelling, discharge, foreign bodies (insects/objects) eardrum - normal, redness, dullness, bulging/retraction, fluid, bubbles, perforations or discharge Check behind the ear (mastoid) for redness, swelling, pain See Ear assessment, p. 519 for detailed assessment <p>Nose</p> <ul style="list-style-type: none"> Feel for facial swelling (sinuses), pain Any discharge or obvious foreign body <p>Throat</p> <ul style="list-style-type: none"> Inspect - lips, buccal mucosa, gums, palate, tongue, throat for: <ul style="list-style-type: none"> colour changes, swelling, bleeding, pus, fissures tonsils - redness, enlargement, pus teeth and gums
Urine	<ul style="list-style-type: none"> Check urine in all sick patients and if: <ul style="list-style-type: none"> abdominal pain (+ do pregnancy test if female of reproductive age) urinary symptoms diabetes Do urinalysis Note colour - normal, dark or blood stained, cloudy Does it smell normal

Step 4: Consider differential diagnosis

- If unsure, collaborate with MO/NP

Step 5: Select *Health Management Protocol (HMP)* or *Clinical Care Guideline (CCG)*

- To guide further assessment and management
- Document the page number of the HMP/CCG referred to in the medical record

Step 6: Order/collect pathology if indicated

- RIPRN:¹⁰
 - may order pathology as per the PCCM
 - name and signature of the MO, NP or RIPRN must be on pathology form or follow local protocol for electronic ordering
 - if RIPRN orders pathology, they are responsible for following up the result
 - consult MO/NP if results are abnormal/concerned about results
- Other clinical staff may be able to request pathology if there is a local agreement in place between the director of the clinical unit and Pathology Qld or local health service
- Write or record on electronic request 'copy of report to...' RFDS/other collaborative health provider on the pathology form as appropriate

- Point of care testing (PoCT) is available in some facilities eg i-STAT
- See Pathology Qld for:
 - pathology test list
 - rural and remote pathology request forms
 - see <https://www.health.qld.gov.au/healthsupport/businesses/pathology-queensland/healthcare>
- If outside Qld refer to local pathology services

Step 7: Collaborate with MO/NP as needed

- Always consult MO/NP if you are unsure
- Have Q-ADDS/CEWT/MEWT score completed
- Use [ISOBAR, p. 25](#) to guide your communication
- Check your local facility guidelines to find out who to contact - during and after hours:
 - **if in doubt call RSQ**

Queensland contacts may include		
Local/on-site MO/NP	<ul style="list-style-type: none"> • Check contact details/on call roster at your workplace 	
Retrieval Services Queensland (RSQ)	<ul style="list-style-type: none"> • 24 hour telehealth, coordination and emergency medical advice • For critically unwell, high acuity patients eg if local doctor not available, or if RSQ is your first point of contact 	<p>1300 799 127</p> <p>Keep your video conferencing equipment switched on at all times. RSQ will make a video conference call. No need to use remote control</p> <p>https://qheps.health.qld.gov.au/rsq</p>
Royal Flying Doctor Service (RFDS) (Queensland Section)	<ul style="list-style-type: none"> • 24 hour routine and emergency medical advice, support and coordination for primary health care facilities where RFDS provide GP and aeromedical retrieval services 	<p>1300 697 337</p> <p>(1300MYRFDS)</p>
Telehealth Emergency Management Support Unit (TEMU)	<ul style="list-style-type: none"> • For lower acuity, non-critical clinical support and advice via video conference • 24 hour, 7 day a week nursing support to rural and remote nursing staff in Queensland Health facilities • Medical and subspecialty support may be available depending on locally agreed pathways 	<p>1800 11 44 14</p> <p>https://qheps.health.qld.gov.au/temsu</p>

Consulting with MO/NP/retrieval co-ordinator¹

- Be clear and methodical
- Write your findings down first, time permitting
- Advise early if you think the patient may need evacuation
- Say what you think is wrong. Your assessment is important

I

Identify yourself **AND** identify name and spelling of receiving MO/NP

- I am ... (your name and role)
- I am calling from ... (location)

S

Situation and **status** - why are you calling

- I have a patient ... (name, age and gender)
- I think the patient is/has ... (clinical impression/suspected diagnosis/unsure but worried)
- Who is ... (stable/unstable/deteriorating/improving)

O

Observations

- Most recent observations
- The Q-ADDS/MEWT/CEWT score is ... (or if outside Qld, local Early Warning and Response System score)
- General appearance
- Weight

B

Background

- History of presenting problem, relevant past history
- Evaluation - physical examination, findings, investigation findings
- Allergies
- Current medicines
- I have ... (taken the following actions eg given O₂, inserted IVC, started IV sodium chloride 0.9%)

A

Agree to a plan

- I am wanting ... (advice, orders, evacuation)
- Level of urgency is ...
- Agree on plan of action with MO/NP/retrieval co-ordinator

R

Recommendations and **read back**

- Confirm shared understanding of what needs to happen - who is doing what and when
- Read back critical information
- Identify parameters for review or escalation
- Identify any risks

Patient retrieval/evacuation

1. Who to contact

- Usually the MO/NP, or Director of Nursing (DON) if possible, will arrange evacuation if required
- Be guided by local facility policy as to which retrieval service to contact:
 - RSQ 1300 799 127
 - RFDS 1300 697 337 if the community is normally serviced by the RFDS (for advice and evacuation). RFDS will advise RSQ of evacuation requirement
- **If you think a patient may need evacuation/retrieval, contact the relevant retrieval service EARLY:**
 - even if transport requirement not confirmed
 - this helps allocate resources
- Notify change of clinical condition of patient if worsening or improving:
 - flight priority can always be reassessed

Retrieval Services Queensland (RSQ) 1300 799 127

- Retrieval Services Queensland:
 - provides clinical coordination for aeromedical transfer for patients from parts of Northern NSW to the Torres Strait
 - utilises multiple government and non-government organisations to achieve aeromedical coverage of Queensland - eg RFDS Qld, QAS, QGAir Helicopter Rescue, Life Flight Retrieval Medicine
 - provide specialist medical and nursing coordinators in adult, paediatric, neonatal and high-risk obstetrics
 - returns patients to referring centres where aeromedical transfer is required
- **Emergency retrieval and transport criteria of patient:**
 - meets early notification of trauma criteria. See [Criteria for early notification of trauma for interfacility transfer \(inside front cover\)](#)
 - requires aeromedical evacuation
 - Q-ADDS/CEWT/MEWT \geq 6 or E
 - > 2 hours/200 km by road to receiving hospital
 - requires medical escort
 - all neonate/high-risk obstetric, critically ill/injured adult and paediatric patients
- For further information <https://qheps.health.qld.gov.au/rts>

Royal Flying Doctor Service (Queensland Section) (RFDS) 1300 697 337

- The Royal Flying Doctor Service in Queensland provides access to primary health care and aeromedical services across the state
- RFDS emergency retrieval service operates 24 hours a day, seven days a week
- In addition to aeromedical retrievals of the critically ill or injured, the RFDS also delivers a broad range of essential primary and preventative healthcare services, including telehealth, mental health, oral health and health promotion

2. Retrieval preparation

Retrieval preparation		
Documentation	<ul style="list-style-type: none"> • Complete retrieval/RFDS Aeromedical retrieval checklist • Ensure documentation goes with patient including: <ul style="list-style-type: none"> – pre-hospital documentation – referral letter – copy of nursing/medical records – pathology results – recent set of clinical observations – up-to-date ECG (especially patient with chest pain) – x-rays – if digital radiology available, electronically transfer x-ray(s) to receiving facility 	
Handover location	<ul style="list-style-type: none"> • Handover location will be determined during the retrieval coordination process • If patient stabilised and prepared, handover at airport/airstrip may occur • Critical and unstable patients will be reviewed at the referring facility by the retrieval team prior to transport 	
Patient escort and baggage Space and weight restrictions apply	<ul style="list-style-type: none"> • If room, an escort may be carried at the discretion of the pilot: <ul style="list-style-type: none"> – name, weight of escort required • Maximum baggage allowance is 1 small bag with a weight of 5 kg • Medical aids/additional baggage at the pilot's discretion • Confirm no cigarette lighters in luggage 	
General preparation		
Consideration	Requirements	Rationale
Allergies/ identification	<ul style="list-style-type: none"> • Apply ID bands if available 	<ul style="list-style-type: none"> • Rapid correct identification
Weight, height + widest point	<ul style="list-style-type: none"> • If > 120 kg, measure width at widest point eg shoulder or hips as per RSQ Bariatric sizing chart (Qld) https://qheps.health.qld.gov.au/rsq/forms 	<ul style="list-style-type: none"> • Assists planning transport
Analgesia	<ul style="list-style-type: none"> • Give analgesia as clinically indicated prior to transfer • See Acute pain, p. 32 	<ul style="list-style-type: none"> • Movement of the patient may exacerbate pain
Antiemetic	<ul style="list-style-type: none"> • Parenteral antiemetic essential if: <ul style="list-style-type: none"> – head, spinal, or penetrating eye injury • Consider for history of motion sickness or general nausea • Give 30 minutes prior to transfer • See Nausea and vomiting, p. 40 	<ul style="list-style-type: none"> • Vomiting may exacerbate certain clinical conditions by raising ICP and intraocular pressure (IOP) • Puts airway at risk • Motion sickness common in aeromedical environment
Intravenous cannula (IVC)	<ul style="list-style-type: none"> • Ensure most patients have at least 1 IVC • IVC x 2 in critically ill/disturbed patients 	<ul style="list-style-type: none"> • IV access may be difficult during flight due to space restrictions and turbulence
Urinary catheter (IDC)	<ul style="list-style-type: none"> • Get patients to empty their bladder prior to transfer • Insert IDC if is/may be incontinent 	<ul style="list-style-type: none"> • No toilet facilities on aircraft • Use of bedpans is avoided due to limitations of space and waste disposal

General preparation (continued)		
Consideration	Requirements	Rationale
Parenteral medicine infusion	<ul style="list-style-type: none"> Prior to transfer prepare infusions using compatible equipment, if possible, when using RFDS or other retrieval services 	<ul style="list-style-type: none"> Time is saved if infusions are prepared prior to RFDS arrival
Nasogastric tube (NGT) or orogastric tube (OGT)	<ul style="list-style-type: none"> Ensure NGT/OGT inserted in: <ul style="list-style-type: none"> – all ventilated patients – patients with bowel obstruction 	<ul style="list-style-type: none"> Allow for drainage of stomach contents and reduce risk of vomiting and aspiration
Nicotine patch	<ul style="list-style-type: none"> Offer to patients who are smokers 	<ul style="list-style-type: none"> Patient comfort
Specific medical conditions		
Consideration	Requirements	Rationale
Mental illness/disturbed behaviour	<ul style="list-style-type: none"> Reliable IV access. If possible IVC x 2 Complete RFDS risk assessment <i>Transfer of disturbed patients including patient with a mental illness</i> Sedation and physical restraint may be required. Seek medical advice 	<ul style="list-style-type: none"> For aviation safety, special requirements apply to transportation of patients showing signs of disturbed behaviour, or regarded as being a danger to themselves or others
Infectious conditions	<ul style="list-style-type: none"> Always advise retrieval coordinator of infectious conditions COVID-19 risk assessment 	<ul style="list-style-type: none"> Limited ability to isolate patients in aircraft
Spinal injury	<ul style="list-style-type: none"> Transport on vacuum mattress Insert IDC Insert NGT if have altered LOC 	<ul style="list-style-type: none"> To maintain stabilisation
Bowel obstruction	<ul style="list-style-type: none"> Insert NGT - leave on free drainage or attach anti-reflux valve (do not spigot) Give parenteral antiemetic and adequate analgesia prior to transfer 	<ul style="list-style-type: none"> Trapped gas will expand in volume at altitude and cause pain. NGT will allow gas to escape and reduce vomiting
Pneumothorax	<ul style="list-style-type: none"> Ensure intercostal catheter in place Connect to Heimlich valve or Portex® ambulatory chest drain system Suspected pneumothorax should be excluded, if possible, by appropriate imaging 	<ul style="list-style-type: none"> Trapped gas in the pleural cavity will expand at altitude and may result in respiratory compromise Underwater seal drains are avoided due to the risk of retrograde flow during transfer
Penetrating eye injury	<ul style="list-style-type: none"> Give antiemetic to all patients with proven or suspected eye injury Patients may be transported at reduced cabin altitude 	<ul style="list-style-type: none"> Trapped gas in the globe will expand at altitude and potentially worsen the injury Vomiting may also exacerbate injury by raising intraocular pressure

 Royal Flying Doctor Service			RFDS Aeromedical Retrieval Checklist		
Date and time of request for retrieval/transport				ETA (will be confirmed in flight)	
PATIENT TRANSPORT DETAILS					
Patient Name:		Patient Weight (kg): Complete Bariatric sizing chart if > 120kg		<input type="checkbox"/> Valuables - Specify:	
Date of Birth:		Sex: M <input type="checkbox"/> F <input type="checkbox"/>		<input type="checkbox"/> Small bag <5kg <i>Any other luggage must be approved by RFDS flight crew</i>	
Address:			Escort (<i>must be approved by RFDS flight crew</i>)		Approval <input type="checkbox"/> Weight (kg)
Diagnosis			Escort Name		Escort Relationship to Patient
Infectious Condition (e.g. MRSA)		Yes <input type="checkbox"/> No <input type="checkbox"/> Specify:		Next of Kin	
Mobility		<input type="checkbox"/> Able to manage stairs		<input type="checkbox"/> Requires Stretcher	
PLEASE NOTE: ■ Please advise RFDS MO or Clinical Coordinator immediately if clinical status deteriorates ■ Any patient with a fear of flying; who is claustrophobic; who is confused, agitated or aggressive must be discussed in full with the RFDS MO or RSQ Clinical Coordinator.					
REFERRAL DETAILS					
Referring facility			Referring Clinician		
Receiving facility			Receiving MO		
CLINICAL INFORMATION (✓ where applicable)					
Infusion concentrations and rates must be documented on a fluid order sheet and a copy sent with the patient.					
	Size	Site	Date Inserted	Infusion(s)	
IV Cannula (1)					
IV Cannula (2) (see General Preparation section)					
<input type="checkbox"/> Toilet prior to flight	<input type="checkbox"/> Urinary Catheter	<input type="checkbox"/> ICC	<input type="checkbox"/> Chest drainage bag	<input type="checkbox"/> Fracture Immobilisation	
<input type="checkbox"/> Gastric Tube (Free Drainage for Flight)	<input type="checkbox"/> Other (Specify)		<input type="checkbox"/>		
Medicines given prior to transfer must be documented on a medication sheet and a copy sent with the patient Ensure adequate analgesia and antiemetic is given if necessary					
Medication given prior to flight			Dose and route given		Time given
Analgesia:					
Antiemetic:					
Sedative:					
Other:					
DOCUMENTATION					
All patients must be accompanied by the appropriate documentation					
Copies/originals of all the following <i>must</i> accompany			Other documentation that <i>may</i> be relevant during transfer		
LETTER: <input type="checkbox"/> Medical <input type="checkbox"/> Surgical		<input type="checkbox"/> Current Medication Sheet <input type="checkbox"/> Fluid Orders <input type="checkbox"/> Fluid Balance Chart <input type="checkbox"/> ECGs <input type="checkbox"/> Pathology Results <input type="checkbox"/> ARP/AHD		<input type="checkbox"/> Inpatient Notes <input type="checkbox"/> Emergency Dept. Flow Sheet <input type="checkbox"/> QAS Report Form <input type="checkbox"/> Theatre Notes <input type="checkbox"/> Immunisation Status <input type="checkbox"/> PTSS Form	
OBSERVATION FORMS: <input type="checkbox"/> Vital Signs <input type="checkbox"/> Neurological Observations <input type="checkbox"/> Blood Glucose Levels				<input type="checkbox"/> QAS MATT Form <input type="checkbox"/> Request for Assessment PATHOLOGY SPECIMENS <input type="checkbox"/> IATA Packing Instruction 650	
HANDOVER					
Handover location and road transport details will be determined by RFDS/RSQ during coordination of the retrieval					
<input type="checkbox"/> Hospital Handover OR		<input type="checkbox"/> RFDS to arrange ambulance OR		Discuss any questions with the RFDS Medical Officer or RSQ Clinical Coordinator, and/or refer to Primary Clinical Care Manual.	
<input type="checkbox"/> Airport Handover		<input type="checkbox"/> Hospital to arrange ambulance			
Additional Comments:				Name:	
				Signature:	

Page intentionally left blank

Pain, nausea and vomiting

Acute pain

HMP Acute pain - adult/child

1. May present with

- Acute pain

2. Immediate management

- If chest pain, go to [Chest pain assessment, p. 103](#)
- **If severe pain:**
 - get rapid history + check for allergies
 - contact MO/NP urgently
 - **adult** - insert IVC + give IV morphine or fentanyl
 - if IVC delay - consider alternative routes eg IM/subcut, inhalation, intranasal
 - **child** - consider intranasal fentanyl. **Note:** must be skilled in the use of this. Use is off-label
- If severe pain + looks sick/'worst I've ever felt' - screen for [Sepsis, p. 64](#)
- If sudden onset severe headache/'worst headache of life' - go to [Headache, p. 127](#)
- If abdominal pain still give analgesia. **Note:** will not mask physical signs/hinder diagnosis

3. Clinical assessment¹

- The most useful diagnostic approach to acute pain is to take a detailed and systematic history
- Ask about:
 - **Site** - where is it
 - **Onset** - when did it start:
 - sudden or gradual
 - result of trauma/activity/cold/stress
 - **Characteristics** eg sharp, throbbing, aching, burning, stabbing
 - **Radiation** - does it spread anywhere else
 - **Associated symptoms** eg nausea, vomiting, sweating, fever
 - **Timing** - duration, constant or intermittent:
 - has anything changed the pain
 - ever had this pain before, how often does it occur
 - **Exacerbating or relieving factors:**
 - eg rest, medicines, eating, position changes, ice/splinting
 - **Severity** - at rest, on movement:
 - mild, moderate, severe
 - scale from 0–10 (0 = no pain, 10 = worst pain imaginable)
 - if child consider FLACC or FACES²
- Ask about:
 - any pain relief already given/taken prior to presentation eg by carer, self, ambulance staff:
 - when, what, dose, how effective
 - pain relief used in past - what worked/did not work, side effects
- Get past history, including:
 - current medicines, over-the-counter medicines
 - opioid use (if any)
- Do vital signs
- If child - do weight, bare weight if < 2 years

Pain assessment scales²⁻⁴

FLACC pain scale - 2 months–7 years (or non-verbal person)			
Observe with legs + body uncovered for 2–5 minutes			
	0	1	2
Face	No particular expression or smile	Occasional grimace or frown, withdrawn, disinterested	Frequent to constant quivering chin, clenched jaw
Legs	Normal position or relaxed	Uneasy, restless, tense	Kicking or legs drawn up
Activity	Lying quietly, normal position, moves easily	Squirming, shifting, back and forth, tense	Arched, rigid or jerking
Cry	No cry (awake or asleep)	Moans or whimpers, occasional complaint	Crying steadily, screams, sobs, frequent complaints
Consolability	Content, relaxed	Reassured by touching, hugging or being talked to, distractable	Difficult to console or comfort

Calculate score: 0 = relaxed + comfortable, 1–3 = mild discomfort, 4–6 = moderate pain, 7–10 = severe discomfort/pain

FACES 4–12 years

“These faces show how much something can hurt. This face [*point to left-most face*] shows no pain. The faces show more and more pain [*point to each from left to right*] up to **this** one [*point to right-most face*]. It shows very much pain. Point to the face that shows how much you hurt [*right now*]”



0 2 4 6 8 10

Clinician to say ‘hurt’ or ‘pain’ (language child understands) - not words like ‘happy’ or ‘sad’

4. Management

- Consult MO/NP if:
 - severe pain even if settled after initial analgesia
 - fever, persistent tachycardia or tachypnoea, or hypotension
 - analgesia is not effective
 - unable to find cause of pain
 - recurrence of pre-existing condition
 - suspected opioid seeking

Analgesia

- Consider medicine(s) already given
- Use step wise approach (below)
- Some causes may require alternative treatment/considerations eg:⁵
 - Head injuries, p. 143 - only give opioids as per MO/NP
 - Headache, p. 127
 - Renal colic, p. 206 - give ketorolac
 - bites and stings - hot water immersion may be effective
 - pregnant woman in Labour 1st stage, p. 400
 - eyes - oxybuprocaine may be indicated. See FB in eye, p. 281
 - Managing injection pain, p. 563
 - if Abdominal pain, p. 196 - still give analgesia (will not mask physical signs/hinder diagnosis)
 - suspected fractures or severe soft tissue injuries immobilisation can ↓ pain significantly

Step wise approach to acute pain management^{2,5,6}

Severity	Analgesia - if not allergic	Practice points
1–3 Mild	Step 1 Non-pharmacological options AND/OR paracetamol	<ul style="list-style-type: none"> • The paracetamol content of all medicines must be considered. Advise max. dosing to take at home
4–6 Moderate	Step 2 As for step 1 AND/OR Ibuprofen AND/OR Oxycodone (adults only)	<ul style="list-style-type: none"> • Combination of paracetamol + ibuprofen is more effective than the use of either alone • Consider oxycodone only if pain is not adequately relieved by paracetamol ± ibuprofen
7–10 Severe	Step 3 As for step 2 AND/OR Further dose of oxycodone OR Morphine or fentanyl	<ul style="list-style-type: none"> • Check/monitor sedation score • Consider intranasal fentanyl for child • Note: IM/subcut absorption may be impaired if poor perfusion eg hypovolaemia, shock • Preferably titrate via IV route

Also consider - **Methoxyflurane** (eg Pentrox®) or **Nitrous oxide** (eg Entonox®) for quick procedures < 10 minutes eg laceration repair, trauma eg while transferring in ambulance etc

Non-pharmacological options^{1,4}

- Ice, massage, heat pack
- Elevation + splinting of injuries
- Repositioning, distraction, imagery
- Reassurance - explain cause of pain + expected outcome to relieve anxiety
- If infant/young child - breastfeeding, low lighting, sucrose, bubbles, cuddling carer/parent

Monitor effect of analgesia

- Repeat pain scale:^{1,4}
 - **mild/moderate pain** - 30–60 minutely as clinically indicated
 - **severe pain** - 10 minutely for 1st 30 minutes, then as required
- Do vital signs as appropriate + give antiemetic if Nausea and vomiting, p. 40
- **Note:** if given subcut, monitor for at least 2 hours due to delayed absorption/adverse effects

Sedation score⁷

- Patient must be woken to assess sedation

Score	Description	Action
0	Awake	<ul style="list-style-type: none"> • Nil
1	Mild - easy to rouse, able to keep eyes open for 10 seconds	<ul style="list-style-type: none"> • Increase monitoring of vital signs, sedation + pain score • Recheck score before giving potentially sedating medication
2	Moderate - rousable but unable to keep eyes open for 10 seconds Early respiratory depression	<ul style="list-style-type: none"> • Give O₂ to maintain SpO₂ ≥ 94% • Stay with patient • Do not give further opioids/sedating medications • Do 15 minutely vital signs, sedation + pain score until sedation score < 2 • Contact MO/NP promptly
3	Severe - difficult to rouse or un-rousable	<ul style="list-style-type: none"> • Stay with patient + call for help • Support airway/breathing + give O₂ to maintain SpO₂ ≥ 94% • Give naloxone, p. 39 if opioid was given • Contact MO/NP urgently • 5 minutely vital signs, sedation + pain score until sedation score < 2

S2	Ibuprofen		Extended authority ATSIHP/IHW/IPAP
ATSIHP, IHW, IPAP, MID and RIPRN may proceed			
RN may administer; for supply see RN supplying, p. 11			
Form	Strength	Route	Dose
Tablet	200 mg 400 mg	Oral	Adult and child ≥ 12 years 200–400 mg
Oral liquid	100 mg/ 5 mL		Child > 3 months–11 years 5–10 mg/kg (max. 400 mg) <i>Round down to the nearest measurable dose</i>
Duration			
stat Then 6–8 hourly as needed			
Max. 48 hours supply (or 1 bottle of liquid)			
Offer CMI: Do not take if dehydrated eg due to vomiting or diarrhoea. Take with a glass of water. If upsets stomach take with food. May cause nausea, indigestion, GI bleeding, diarrhoea, headache, dizziness, fluid retention or hypertension			
Note: If renal impairment, taking diuretics, ACEIs, or ARBs consult MO/NP. Use with caution if asthma, cardiovascular disease or ↑ cardiovascular risk, taking lithium or anticoagulants			
Pregnancy: May ↑ rate of miscarriage. Seek specialist advice for use in the 2nd half of pregnancy; do not use during the last few days before expected birth			
Contraindication: Dehydration, active peptic ulcer disease or GI bleeding, severe renal, heart or liver failure, coagulation disorders			
Management of associated emergency: Consult MO/NP. See Anaphylaxis, p. 82			

8

S2	Paracetamol			Extended authority ATSIHP/IHW/IPAP
ATSIHP, IHW, IPAP, MID and RIPRN may proceed				
RN may administer; for supply see RN supplying, p. 11				
Form	Strength	Route	Dose*	Duration
Tablet	500 mg	Oral	Adult and child ≥ 12 years 500 mg–1 g (max. 8 tablets/4 g in 24 hours)	stat Then 4–6 hourly as required
Oral liquid	120 mg/5 mL 100 mg/mL		Child > 1 month–11 years 15 mg/kg (max. 1 g) <i>Round down to nearest measurable dose</i> (max. 60 mg/kg in 24 hours. Do not exceed 4 g in 24 hours)	Max. 48 hours supply (or 1 bottle of liquid)
Suppository	125 mg 250 mg 500 mg	PR	Adult and child ≥ 12 years 500 mg–1 g	stat
			Child > 1 month–11 years 15 mg/kg (max. 1 g) <i>Round down to nearest strength</i>	Further doses on MO/NP orders
<p>Offer CMI: Too much paracetamol can cause liver damage. No more than 4 g should be given to an adult patient in 24 hour period. Doses should not be given more frequently than 4–6 hours. Check paracetamol content of other medicines being taken eg over-the-counter medicines, cough + cold products</p> <p>Note: If hepatic impairment consult MO/NP. *Reduce dose if risk factors for toxicity ie Adult: (dehydration, alcohol use, under-nutrition, anticonvulsants, elderly/frail) - if ≥ 50 kg, ↓ max. dose to 3 g/24 hours; if < 50 kg, give 15 mg/kg (max. 4 doses/24 hours). Child: (fever, dehydration, under-nutrition, or if < 5 kg) - ↓ max. dose to 45 mg/kg/24 hours (do not exceed 3 g/24 hours). Also see Guideline for safe paracetamol use https://www.health.qld.gov.au/clinical-practice/guidelines-procedures/medicines/safety</p> <p>Management of associated emergency: Consult MO/NP. Recognise + treat suspected Paracetamol toxicity, p. 218 without delay. Contact Poisons Information Centre ☎ 131 126 9-11</p>				

S8	Oxycodone			Extended authority ATSIHP/IHW/RIPRN
ATSIHP, IHW and RN must consult MO/NP				
RIPRN may proceed				
Form	Strength	Route	Dose	Duration
Tablet (immediate release)	5 mg	Oral	Adult only 5 mg	stat Repeat after 4 hours if needed Further doses on MO/NP order
<p>Offer CMI: May cause nausea, vomiting, itch, drowsiness, dizziness, headache, constipation, low BP when moving to standing, indigestion or dry mouth</p> <p>Note: If elderly/frail, renal or hepatic impairment, acute alcoholism or delirium tremens seek MO/NP advice. Monitor sedation score + RR</p> <p>Pregnancy: One dose is safe. Consult MO/NP if ongoing need</p> <p>Contraindication: Acute or severe bronchial asthma or other obstructive airways disease, head injuries, raised ICP, respiratory depression</p> <p>Management of associated emergency: Consult MO/NP. See Anaphylaxis, p. 82. Give naloxone if overdose 6,12</p>				

S8	Morphine		Extended authority ATSIHP/IHW/MID/RIPRN		
ATSIHP, IHW and RN must consult MO/NP					
RIPRN may proceed EXCEPT for pregnant women					
MID may proceed for intrapartum use only. IM/subcut routes only					
Form	Strength	Route	Dose		Duration
Injection	10 mg/mL	IM/Subcut Note: start at lower end of dose range, titrate to response + sedation score	Adult only		stat Further doses on MO/NP order
			Age (years)	mg	
			< 40	7.5–10	
			40–60	5–10	
			60–70	2.5–7.5	
			70–85	2.5–5	
		> 85	2–3		
		IV Dilute with 9 mL water for injections to make a concentration of 1 mg/mL	Adult only 0.5–2 mg increments (max. 10 mg) Give lower dose if > 70 years ¹³		stat Inject slowly over 4–5 minutes Repeat every 5 minutes if needed based on response + sedation score (max. 10 mg). Further doses on MO/NP order
Offer CMI: May cause nausea, vomiting, itch, drowsiness, dizziness, headache, constipation, low BP when moving to standing, dry mouth, sweating or dysphoria					
Note: Monitor sedation score + RR. Use with caution in > 70 years + significant renal or liver disease (reduce dose). Fentanyl is more appropriate in renal disease					
Contraindication: Acute or severe bronchial asthma or other obstructive airways disease, head injuries, raised ICP					
Management of associated emergency: Consult MO/NP. See Anaphylaxis, p. 82 . Give naloxone if overdose					

6,13,14

S8	Fentanyl		Extended authority ATSIHP/IHW/RIPRN			
ATSIHP, IHW and RN must consult MO/NP						
RIPRN may proceed for adult. If child - must consult MO/NP unless circumstances do not allow, in which case consult MO/NP as soon as circumstances allow						
Form	Strength	Route	Dose		Duration	
Injection	100 microg/ 2 mL	Subcut	Adult only		stat Further doses on MO/NP order	
			Age (years)	microg		
			< 40	100		
			40–60	75–100		
			60–70	40–100		
			70–85	40–75		
		> 85	30–50			
		IV	Use undiluted or add sodium chloride 0.9% to facilitate slow injection	Adult only		stat Inject slowly over 3–5 minutes
		10–20 microg increments (max. 100 microg)		Repeat every 5–10 minutes if needed based on response + sedation score (max. 100 microg)		
		Intranasal* Use mucosal atomiser device (MAD)	Note: IHW + ATSIHP may NOT administer intranasal	Child 1–12 years		stat Divide dose between nostrils to minimise swallowing + effects eg sneezing
1.5 microg/kg (max. 100 microg) Note: add 0.1 mL to initial dose to accommodate MAD dead space	May repeat after 5–10 minutes on MO/NP order					
Offer CMI: May cause rash, bradycardia, drowsiness, dizziness, headache, low blood pressure when moving to standing or dry mouth						
Note: Monitor sedation score + RR. *Intranasal is off-label use - ensure documentation + evaluation is undertaken as per CATAG guiding principles for the quality use of off-label medicines www.catag.org.au . Use with caution if > 70 years						
Contraindication: Acute or severe bronchial asthma or other obstructive airways disease, concurrent use with MAO inhibitors, head injuries, raised ICP						
Management of associated emergency: Consult MO/NP. See Anaphylaxis, p. 82 . Give naloxone if overdose						

6,15,16

S4	Nitrous oxide + oxygen (Entonox®)			Extended authority ATSIHP/IHW/RIPRN/SRH
ATSIHP, IHW and RN must consult MO/NP				
RIPRN may proceed. SRH may proceed for adults only				
Form	Strength	Route	Dose	Duration
Premix gas	Nitrous oxide 50% + oxygen 50%	Inhalation	Adult + child > 4 years self administered as needed	short-term use only
Offer CMI: Patient must self administer ie hold the mouthpiece or mask (not clinician or parent). Pain relief after 5–8 breaths + wears off quickly. May cause dizziness, nausea and brief disinhibition				
Note: Use with caution if opioid given				
Contraindication: Heart failure, severe cardiac impairment, may worsen/cause myocardial depression. Air containing cavities eg middle ear occlusion, abdominal distension, pneumothorax - risk of ↑ pressure ± volume in cavities				
Management of associated emergency: Consult MO/NP. Give oxygen if overdose				17,18

S4	Methoxyflurane			Extended authority ATSIHP/IHW/RIPRN
ATSIHP, IHW and RN must consult MO/NP				
RIPRN may proceed				
Form	Strength	Route	Dose	Duration
Inhalation solution	99.9%	Inhalation	Adult + child ≥ 6 years 3 mL	stat Can repeat after 20 minutes (max. 6 mL/day)
Offer CMI: Pain relief after 6–10 breaths + continues for several minutes after stopping. May cause mild dizziness, drowsiness or headache				
Note: Self-administered with supervision. Only use if conscious + cooperative. Use in well ventilated area to minimise non-patient exposure. Do not use on consecutive days or exceed 15 mL/week				
Contraindication: Susceptibility to malignant hyperthermia				
Management of associated emergency: Consult MO/NP. See Anaphylaxis, p. 82				17,19

S3	Naloxone			Extended authority ATSIHP/IHW
ATSIHP, IHW, RIPRN and RN may proceed				
Form	Strength	Route	Dose	Duration
Injection	400 microg/mL	IV	Adult 100–200 microg	stat Can repeat every 2 minutes (max. 10 mg)
		IM	Adult 400 microg Child 10 microg/kg (max. 400 microg)	stat Can repeat in 5 minutes/as per MO/NP
Nasal spray	1.8 mg/actuation	Intranasal	Adult + child 1.8 mg (1 spray into 1 nostril)	stat Can give 2nd dose (using new device) into other nostril after 2–3 minutes
Note: Repeat doses until patient is more awake and breathing adequately. Patient should improve in 1 minute. Failure to respond may indicate another cause of unconsciousness. The duration of naloxone is short (15–30 minutes) compared to opioids. Continue observation + monitor RR. May cause an acute withdrawal syndrome in those with opioid dependence ie anxiety, agitation, tachycardia, confusion, seizures, pulmonary oedema or arrhythmias				
Pregnancy: Do not use in opioid dependent women, risk of withdrawal in fetus				
Management of associated emergency: Consult MO/NP. See Anaphylaxis, p. 82				6,20

5. Follow up

- Patients needing morphine/fentanyl will likely need evacuation for further management
- If not evacuated, follow up as per MO/NP + likely cause of pain
- If supplied with paracetamol or ibuprofen + further pain relief is needed after 48 hours, consult MO/NP

6. Referral/consultation

- Consult MO/NP if further analgesia is needed + max. dose has been given

Nausea and vomiting

HMP Nausea and vomiting - adult/child

Recommend

- Always consider life-threatening causes eg bowel obstruction, mesenteric ischaemia, acute pancreatitis + myocardial infarction¹
- Offer antiemetic for aeromedical retrieval prophylaxis

Background

- In the absence of abdominal pain, significant headache or recent initiation of certain medicines, nausea + vomiting is usually caused by self-limiting viral gastroenteritis¹

1. May present with

- Nausea ± vomiting

2. Immediate management

- If related to chest pain, go to [Chest pain assessment, p. 103](#)

ALERT suspect [Button battery, p. 80](#) in all children if vomiting blood. A button battery lodged in the oesophagus can burn a hole through to the aorta causing catastrophic haemorrhage

3. Clinical assessment

Check for red flags^{1,2}

- | | |
|---|---|
| • Prolonged vomiting | • Severe headache, altered LOC |
| • Looks very unwell/very drowsy | • Isolated vomiting, lack of nausea |
| • Significant weight loss | • History of head trauma/injury |
| • Abdominal distension or tenderness | • Bulging fontanelle - infant/young child |
| • Rectal bleeding | • Child - T > 39 or 38 if < 3 months of age |
| • Green, bile or blood/coffee grounds vomit | • Projectile vomiting if 3–6 weeks of age. See Pyloric stenosis, p. 544 |
| • Fever, neck stiffness, confusion | • ↑ BGL |

- Always try to identify the cause of the nausea/vomiting
- Get history, including:¹

- frequency of vomiting
- timing in relation to eating
- food eaten in last 24 hours - could it be food poisoning
- similar symptoms in family members/close contacts
- pregnancy
- exposure to toxins/poisons/bites/stings
- recent illicit drug use, alcohol/hangover related
- recent travel
- Ask about other symptoms eg:¹
 - chest pain, heartburn
 - headache, vertigo or dizziness
 - last bowel motion, any diarrhoea
 - related to motion/travel
 - dysuria or frequency of urine
 - fever
- Get past history, including:¹
 - current medicines, over-the-counter medicines, previous antiemetics
 - recent initiation of a new medicine(s)
 - diabetes
 - abdominal surgery
- Do vital signs
- BGL if cause unknown or history of diabetes:¹
 - ↑ BGL with nausea ± vomiting - may indicate [DKA, p. 89](#)
 - ↓ BGL consider [Hypoglycaemia, p. 91](#) as cause
- Do physical examination, including:
 - [Hydration assessment - adult, p. 200](#) or [child, p. 535](#)
 - plus as determined from history taking eg:
 - [abdominal examination, p. 197](#)
 - urinalysis. **Note:** urinalysis cannot reliably exclude UTI in infants + young children
 - pregnancy test if female of reproductive age
 - if child do weight, bare weight if < 2 years

4. Management

- Urgently contact MO/NP if:
 - any red flags
- Contact MO/NP if:
 - child/infant, also see [Child with vomiting, p. 492](#)
 - no obvious cause/unsure
 - suspected poisoning
 - patient has re-presented
- If pregnant - seek advice from midwife/MO/NP - avoid antiemetic if possible:^{1,3}
 - severe vomiting that starts in late pregnancy may indicate [Preeclampsia, p. 386](#)
 - if hyperemesis gravidarum (extreme morning sickness) MO/NP may order ondansetron
- Otherwise, treat cause if known - be guided by relevant topic
- If probable gastroenteritis ± dehydrated, see [Gastroenteritis - adult, p. 200](#) or [Gastroenteritis - child, p. 535](#)

- Offer antiemetic as needed for initial symptom relief of nausea + vomiting:
 - monitor effect - contact MO/NP if not effective

S4	Metoclopramide			Extended authority
ATSIHP, IHW and RN must consult MO/NP				
MID and RIPRN may proceed				
Form	Strength	Route	Dose	Duration
Tablet	10 mg	Oral IM IV	Adult ≥ 20 years 10 mg	stat
Injection	10 mg/2 mL			Inject IV dose slowly over at least 3 minutes Further doses on MO/NP order
Offer CMI: May cause drowsiness, dizziness or headache. Avoid driving or operating heavy machinery if affected. Report uncontrolled or repeated body movements eg face, mouth or tongue				
Note: If renal impairment seek MO/NP advice				
Contraindication: Parkinson's disease, pheochromocytoma + conditions where ↑ GI motility may be harmful eg GI obstruction or perforation				
Management of associated emergency: Consult MO/NP. See Anaphylaxis, p. 82 . If extrapyramidal adverse effects + acute dystonic reaction (within minutes to days) treat with benztropine				

4

S4	Ondansetron			Extended authority
ATSIHP, IHW, MID and RN must consult MO/NP				
RIPRN may proceed (max. 4 mg IV, 8 mg oral)				
Form	Strength	Route	Dose	Duration
Orally disintegrating tablet	4 mg	Oral	Adult 4–8 mg	stat
			Child > 6 months–16 years Oral 8– < 15 kg - 2 mg 15–30 kg - 4 mg > 30 kg - 8 mg IV 0.15 mg/kg (max. 8 mg)	Inject IV dose slowly over at least 5 minutes, or 15 minutes if > 75 years Further doses on MO/NP orders
Injection	4 mg/2 mL	IV		
Offer CMI: Put tablet on top of tongue to dissolve, then swallow. May cause dizziness or headache				
Note: If child - useful if related to gastroenteritis/unable to tolerate oral fluids. If adult - use for non-specific nausea + vomiting is off-label. Ensure documentation + evaluation is undertaken as per CATAG guiding principles for the quality use of off-label medicines www.catag.org.au . Seek MO/NP advice if hepatic impairment, phenylketonuria, prolonged QT interval or risk factors for prolonged QT interval				
Management of associated emergency: Consult MO/NP. See Anaphylaxis, p. 82				

5,6

S ₄	Benzatropine			Extended authority ATSIHP/IHW/MID/RIPRN
ATSIHP, IHW and RN must consult MO/NP				
RIPRN may proceed. MID may proceed with oral dose only				
Form	Strength	Route	Dose	Duration
Tablet	2 mg	Oral	Adult only	stat
Injection	2 mg/2 mL	IM	1–2 mg	Further doses on MO/NP order
Offer CMI: May cause drowsiness, dizziness or blurred vision. May increase effects of alcohol				
Contraindication: GIT or urinary obstruction, myasthenia gravis				
Management of associated emergency: Consult MO/NP. See Anaphylaxis, p. 82				
				7,8

5. Follow up

- As per MO/NP + cause of nausea/vomiting

6. Referral/consultation

- As above

Page intentionally left blank

Emergency

Resuscitation

Basic life support (BLS) - adult/child DRSABCD resuscitation, the collapsed patient

Recommend¹⁻⁴

- Good quality CPR and reducing time to defibrillation are the highest priorities in resuscitation from sudden cardiac arrest
- Airway takes precedent over any injury, including possibility of spinal injury - handle gently with no twisting or bending of spinal column or neck¹
- If pregnant, once CPR in progress put padding such as a towel under the woman's right hip to tilt the hips about 15–30°, but leave her shoulders flat
- Child/infant - central pulse palpation may be used to assess circulation. If a pulse cannot be definitely identified within 10 seconds (or HR < 60 with signs of poor circulation) start CPR⁵

Background²

- Agonal breaths (occasional irregular gasps) are common in early stages of cardiac arrest

1. May present with²

- Sudden collapse
- Unresponsive and absent or abnormal breathing eg gasping

2. Immediate management¹⁻⁶

- **DRSABCD** as per **Basic life support flowchart**
- **Danger** - check the environment/patient surroundings are safe before proceeding. PPE as needed
- **Response** - verbal and tactile stimuli (talk and touch)
- **Send for help** - shout for help. If help not arrived in 1 minute go get help⁵ + contact MO/NP/RSQ
- **If trauma related** control [catastrophic haemorrhage, p. 134](#)
- **Airway** (leave person in position found):^{1,5}
 - open using **head tilt–chin lift** or **jaw thrust** (if neck injury, only use jaw thrust) +
 - child - head in 'sniffing position'
 - infant < 1 year - head in neutral position
 - **if fluid/matter obstructs airway** at any time:
 - use suction if available OR if unavailable, roll on to side to clear airway¹
 - if visible material, remove if possible eg using rescuer's fingers¹
- **Breathing:**
 - **Look** (movement of chest/abdomen), **Listen** (for breath sounds), **Feel** (air on rescuer's cheek)⁵
 - if unresponsive but breathing normally, see [Unconscious patient, p. 60](#)
- **If unresponsive + breathing absent or NOT normal, place on firm surface and start CPR:**
 - 30 compressions: 2 ventilations² (adult + child) **OR**
 - if paediatric BLS trained - **child:** 2 ventilations (first): 15 compressions⁵
 - 100–120 compressions per minute
- **Defibrillation - attach automated external defibrillator (AED) as soon as available and follow prompts:**
 - **adult and child > 8** use adult pads. **Child 1–8** use paediatric pads (or adult size if not available)
 - continue CPR + minimise interruptions to chest compressions

- alternate person doing compressions when AED advises to stop (eg to analyse rhythm/shock) or if fatigued
- **Get ALS trained clinician(s) if available**
- Continue CPR until responsive, normal breathing returns, or MO/NP instructs otherwise

3. Clinical assessment - see Immediate management

4. Management

- Control bleeding, protect from weather + other first aid measures depending on circumstances

Basic life support flowchart

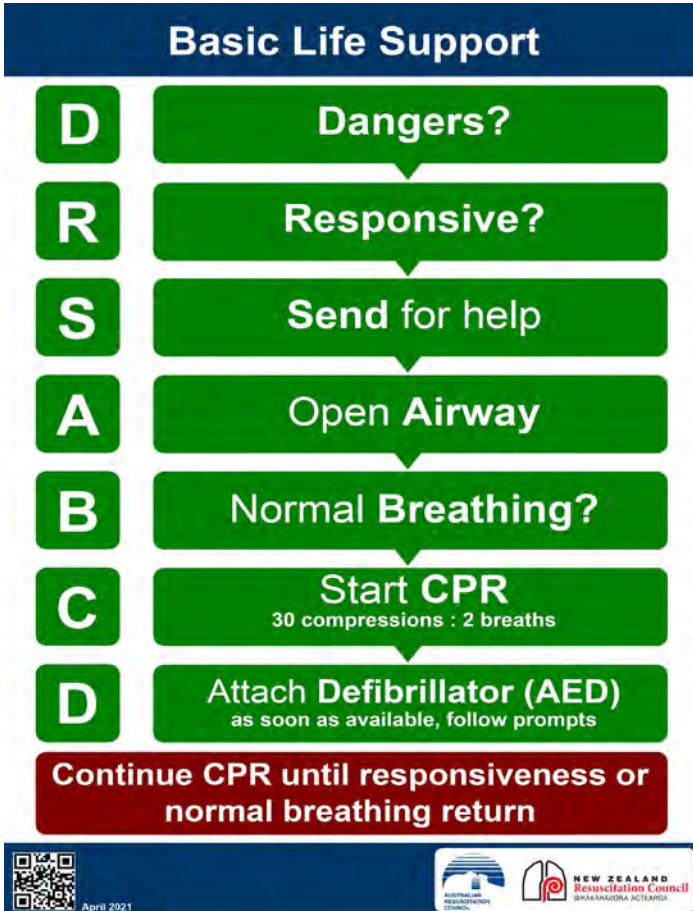

5. Follow up

- According to patient's condition/presentation

6. Referral/consultation

- As above

Advanced life support (ALS) - adult/child

Recommend¹

- As soon as possible use ALS treatments to supplement BLS
- Good quality CPR and reducing time to defibrillation are the highest priorities in resuscitation
- Child/infant - central pulse palpation may be used to assess circulation. If a pulse cannot be definitely identified within 10 seconds (or HR < 60 with signs of poor circulation) start CPR²
- In Qld, refer to **Children's resuscitation emergency drug dosage (CREDD)** <https://www.childrens.health.qld.gov.au/qpec-paediatric-resuscitation-tools/#tab-6ff1bb73468033104a2>

1. May present with^{1,2}

- Sudden collapse
- Unresponsive and absent or abnormal breathing eg gasping

2. Immediate management¹⁻³

- **DRSABCD** + when able, contact MO/NP/RSQ
- **If trauma related⁴** control [catastrophic haemorrhage, p. 134](#)
- **CPR:**
 - **adult** - 30 compressions: 2 ventilations
 - **child/infant** - 2 ventilations (first): 15 compressions
 - 100–120 compressions per minute (**1 loop**)
- **Attach defibrillator pads + assess rhythm as soon as defibrillator available**

If **SHOCKABLE** rhythm - VF or pulseless VT

- **Administer a single shock:**
 - adult and child > 8 years: **as per AED** or if manual defibrillator **200 joules** for all shocks³
 - infant and child to 8 years: **4 joules/kg**. See [Estimated weight \(kg\) based on age, p. 49](#)
- **Immediately resume CPR for 2 minutes:**
 - unless responsiveness or breathing normally
- **After 2 minutes** reassess rhythm:
 - direct treatment as per rhythm eg if shockable administer another shock
- **Continue above loop** (ie shock, CPR for 2 minutes, reassess rhythm, treat as per rhythm)
- **Give IV/intraosseous:**^{2,5}
 - **adrenaline (epinephrine)** after **2nd shock** then every 2nd loop of CPR (3–5 minutely)
 - **amiodarone** after **3 shocks** on MO/NP order

If **NON-SHOCKABLE** rhythm - asystole or Pulseless Electrical Activity (PEA)¹

- Continue CPR - do not shock
- **Give adrenaline (epinephrine) IV/intraosseous** + then every 2nd loop of CPR (3–5 minutely)^{2,5}

ALS interventions - do during CPR in all cases (minimising interruptions to CPR)^{1,2}

- 100% O₂ when available
- IV or [Intraosseous, p. 57](#) access
- Consider airway adjuncts eg oro/nasopharyngeal airway, [LMA, p. 56](#) (once inserted, continue CPR without breaks for ventilation)
- Waveform capnography (end-tidal CO₂) monitoring if available

S3	Adrenaline (epinephrine)			Extended authority NIL
MID, RIPRN and RN may proceed				
Form	Strength	Route	Dose	Duration
Injection	1:10,000 (1 mg/10 mL) OR if unavailable dilute 1:1,000 (1 mg/mL) with 9 mL sodium chloride 0.9%	IV/ Intraosseous	Adult 1 mg	stat then every 2nd loop (3–5 minutely) Rapid injection Then flush with sodium chloride 0.9% (small bolus for child; 20–30 mL for adult)
	Child Birth (term)–18 years 10 microg/kg (max. 1 mg) Note: 10 microg = 0.1 mL adrenaline (epinephrine) 1:10,000			
Management of associated emergency: Consult MO/NP				2,5,6

S4	Amiodarone			Prescribing guide
MID, RIPRN and RN only. Must be ordered by an MO/NP				
Form	Strength	Route	Dose	Duration
Injection	150 mg/ 3 mL	IV/Intraosseous Dilute in 20 mL of glucose 5% (see CREDD for child dilution)	Adult 300 mg Repeat dose of 150 mg can be considered	stat after 3rd shock Inject over 1–2 minutes Then flush with glucose 5% (small bolus for child; 20–30 mL for adult)
			Child 1 month–18 years 5 mg/kg (max. 300 mg) Can be repeated	
Note: Incompatible with sodium chloride 0.9%. If necessary the dose can be injected undiluted and followed immediately with at least 20 mL glucose 5% or sodium chloride 0.9%				
Management of associated emergency: Contact MO/NP				2,5,7

Estimated weight (kg) based on age ⁸										
Birth (term)	1 month	2 months	3 months	4 months	6 months	9 months	1 year	2 years	3 years	4 years
3.5	4	5	6	7	8	9	10	12	14	16
5 years	6 years	7 years	8 years	9 years	10 years	11 years	12 years	13 years	14 years	
18	20	22	25	28	30	35	40	45	50	

Look for + correct reversible causes in collaboration with MO/NP^{1,2}

- Get rapid history from witnesses if able:
 - physical circumstances
 - medicines/allergies
 - precipitating events/symptoms
- Consider 4 Hs and 4 Ts:
 - **Hypoxaemia** - 100% O₂ via bag-valve-mask
 - **Hypovolaemia** - rapid IV sodium chloride 0.9% 20 mL/kg. Stop obvious bleeding/other causes
 - **Hyper/hypokalaemia + metabolic disorders**. Consider i-STAT - UE + BGL
 - **Hyper/hypothermia**:⁹
 - ↓ T - remove wet clothing/rewarm as per [Hypothermia, p. 186](#)
 - ↑ T - rapid cooling as per [Hyperthermia, p. 188](#)
 - **Tension pneumothorax** - do [Needle decompression, p. 141](#)
 - **Tamponade**

- **Toxins/poisons/drugs** - if possible remove source ± Poisons Information Centre ☎ 13 11 26
- **Thrombosis** pulmonary/coronary. If adult with suspected PE, p. 125 MO/NP may consider fibrinolysis

3. Clinical assessment

- See **Immediate management**

4. Management

- Be guided by MO/NP as to when to cease CPR + in consultation with family if present
- **Prolonged CPR recommended in some circumstances** eg:
 - poisonings - get advice from toxicologist if possible¹⁰
 - electrical injury, lightning strike - fixed and dilated pupils may be transient¹¹
 - box jellyfish stings¹²
 - drowning¹³
 - hypothermia - until rewarmed to T at least 32 or as per MO/NP¹⁴
 - if PE and fibrinolysis given⁵

Return of spontaneous circulation (ROSC)

- Suspect ROSC if regular respiratory effort, movement, or readings from monitors compatible with ROSC/pulse. Check for a pulse, if palpable continue with post resuscitation care, otherwise continue CPR¹⁵

Post resuscitation care^{16,17}

- Commences once ROSC occurs:
- Re-evaluate patient - ABCDE
- Urgent evacuation
- In collaboration with MO/NP, monitor/do:
 - vital signs:
 - SpO₂ - aim for 94–98%
 - systolic BP - aim for > 100 (adult). As guided by MO/NP for child
 - temperature - aim for 36–37.5 (if still unresponsive can be as low as 32)
 - avoid **Hyperthermia**, p. 188 + treat aggressively if occurs¹⁷
 - BGL frequently. As needed, see **Hypoglycaemia**, p. 91
 - ECG + continuous cardiac monitoring
 - ± chest x-ray
- MO/NP may consider antiarrhythmic to prevent recurrent VF
- Assess for resuscitation related injuries + continue to investigate for reversible causes

5. Follow up¹

- Sensitive, professional debriefing of people involved in resuscitation is valuable
- Provide support for family members
- If required, see **Patient death in absence of MO**, p. 561

6. Referral/consultation

- Always contact MO/NP

Advanced Life Support for Adults

<p>During CPR</p> <ul style="list-style-type: none"> Airway adjuncts (LMA / ETT) Oxygen Waveform capnography IV / IO access <p>Plan actions before interrupting compressions (e.g. charge manual defibrillator)</p> <p>Drugs</p> <p>Shockable</p> <ul style="list-style-type: none"> * Adrenaline 1 mg after 2nd shock (then every 2nd loop) * Amiodarone 300mg after 3 shocks <p>Non Shockable</p> <ul style="list-style-type: none"> * Adrenaline 1 mg immediately (then every 2nd loop) <p>Consider and Correct</p> <ul style="list-style-type: none"> Hypoxia Hypovolaemia Hyper / hypokalaemia / metabolic disorders Hypothermia / hyperthermia Tension pneumothorax Tamponade Toxins Thrombosis (pulmonary / coronary) 	<p>Post Resuscitation Care</p> <p>Re-evaluate ABCDE</p> <p>12 lead ECG</p> <p>Treat precipitating causes</p> <p>Aim for: SpO2 94-98%, normocapnia and normoglycaemia</p> <p>Targeted temperature management</p>
--	--

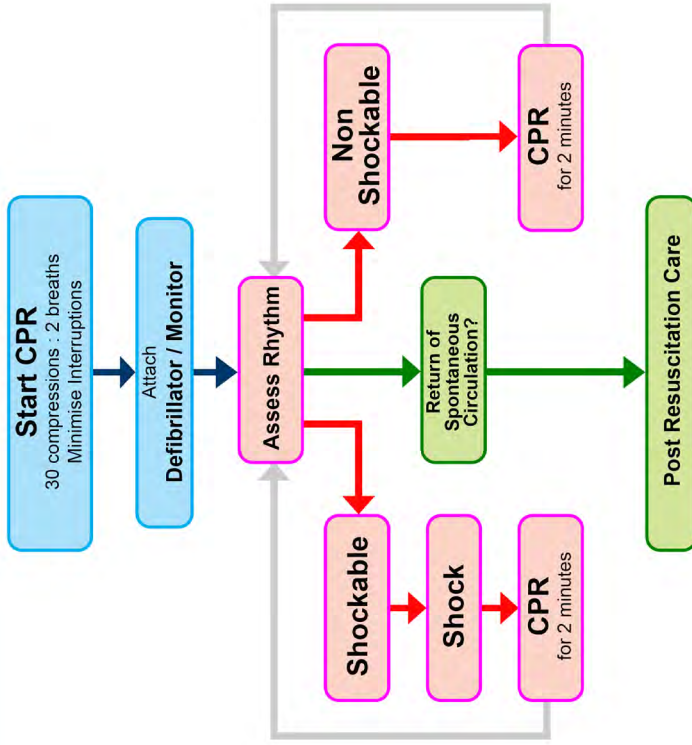

January 2016



Advanced Life Support for Infants and Children

<p>During CPR</p> <ul style="list-style-type: none"> Airway adjuncts (LMA / ETT) Oxygen Waveform capnography IV / IO access <p>Plan actions before interrupting compressions (e.g. charge manual defibrillator to 4 J/kg)</p> <p>Drugs</p> <p>Shockable</p> <ul style="list-style-type: none"> * Adrenaline 10 mcg/kg after 2nd shock (then every 2nd loop) * Amiodarone 5mg/kg after 3 shocks <p>Non Shockable</p> <ul style="list-style-type: none"> * Adrenaline 10 mcg/kg immediately (then every 2nd loop) <p>Consider and Correct</p> <ul style="list-style-type: none"> Hypoxia Hypovolaemia Hyper / hypokalaemia / metabolic disorders Hypothermia / hyperthermia Tension pneumothorax Tamponade Toxins Thrombosis (pulmonary / coronary) 	<p>Post Resuscitation Care</p> <ul style="list-style-type: none"> Re-evaluate ABCDE 12 lead ECG Treat precipitating causes Re-evaluate oxygenation and ventilation Targeted Temperature Management
---	--

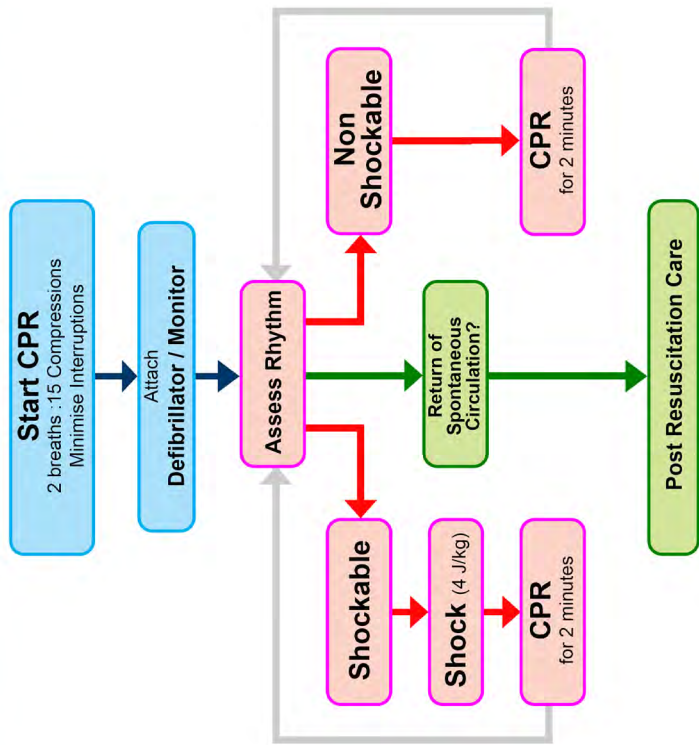



Oxygen delivery

Oxygen delivery - adult/child

Recommend

- Oxygen is a therapeutic intervention + should only be given if clinically indicated¹

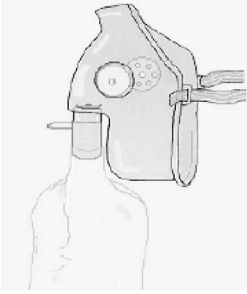
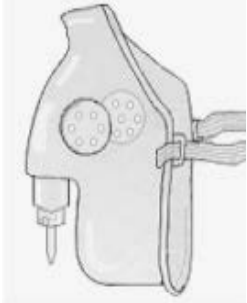
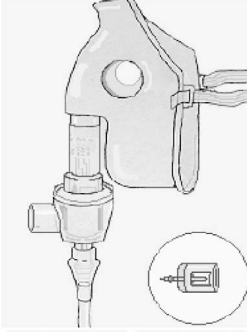
Oxygen use in specific scenarios ¹⁻³		
Scenario	Recommendation	Target SpO ₂
Shock Major trauma Sepsis Other critical illnesses	<ul style="list-style-type: none"> • Give high flow O₂ with non-rebreathing mask at 15 L/minute until stable 	≥ 94%
Acute stroke	<ul style="list-style-type: none"> • Give if SpO₂ < 92% 	
Hypotension	<ul style="list-style-type: none"> • Give until hypoxia can definitely be excluded 	
Carbon monoxide poisoning eg house fire	<ul style="list-style-type: none"> • 15 L/minute O₂ with non-rebreather mask for 6 hours • Keep at rest to minimise O₂ needs • Pulse oximetry is unreliable + may give false normal or high reading 	
Suspected decompression illness or pulmonary barotrauma after diving	<ul style="list-style-type: none"> • Give near 100% O₂ as soon as possible + even if pulse oximetry indicates ↑ SpO₂ • Continue until advised by MO/NP 	
Paraquat poisoning Previous treatment with Bleomycin	<ul style="list-style-type: none"> • Do not routinely administer O₂ - can be hazardous • Only give if arterial O₂ saturation falls below 90% 	88–92%
Patients at risk of hypercapnic respiratory failure (HRF) eg <ul style="list-style-type: none"> • Previous HRF • COPD, bronchiectasis, cystic fibrosis • History of heavy smoking • Obstructive sleep apnoea • BMI > 40 • Severe kyphoscoliosis or ankylosing spondylitis • Neuromuscular disorders with respiratory muscle weakness • Use of opioids, benzodiazepines • Patients with acute asthma who are tiring 	<ul style="list-style-type: none"> • Do not routinely administer O₂ - can be hazardous • Normal SpO₂ is sometimes 90–92% • Excess O₂ can lead to elevated SpO₂ > 95% which ↓ respiratory drive leading to under-ventilation • Use capnometry if available 	88–92%

Oxygen delivery systems ^{1,4,5}			L/minute
<p>Non-rebreathing mask (mask with reservoir)</p>	<ul style="list-style-type: none"> • Partial or full non-rebreathing • High flow device • Ensure O₂ flow keeps reservoir inflated 		8–15
<p>Simple face mask (Hudson mask)</p>	<ul style="list-style-type: none"> • If require > 10 L/minute use non-rebreathing mask 		5–10
<p>Venturi face mask</p>	<ul style="list-style-type: none"> • Colour coded dilution jets delivering various % of high flow O₂ • Select the appropriate jet + O₂ flow rate according to manufacturer's instructions 		As per manufacturer's instructions
<p>Nasal prongs</p>	<ul style="list-style-type: none"> • Neonate max. 1 L/minute • Child < 2 years max. 2 L/minute • Child > 2 years—adult max. 4 L/minute • If requires more than 4 L/minute use a face mask 		0.125–4

Continuous positive airway pressure (CPAP) if skilled^{5,6}

- Use local guidelines eg > 16 years Qld Ambulance Service *Respiratory/non-invasive ventilation - CPAP* <https://www.ambulance.qld.gov.au/CPPTable.html>
- **Indications:**
 - acute pulmonary oedema
 - life-threatening asthma
- **Only use if:**
 - GCS > 8, conscious +
 - able to protect own airway + manage respiratory secretions
- **Set up equipment** as per manufacturer's instructions
- **Ensure a good seal:**
 - check that inner circumference of air cushion of face mask encompasses bridge of nose, side of mouth + lower border of bottom lip with mouth slightly open⁵
- **Oxygen flow rate:**
 - adult - initially 8 L/minute to generate 5 cm H₂O of CPAP. Gradually increase to max. 15 cm H₂O
 - < 16 years - consult MO/NP
- Maintain SpO₂ 90% or as per MO/NP
- Stay with patient where possible
- Nurse sitting up or semi recumbent. Consider side lying if obese abdomen or pregnant

Monitor closely:

- Continuous:
 - SpO₂
 - cardiac monitoring
- Chest sounds, chest wall movement, accessory muscle use
- Patient comfort, skin integrity under mask/straps + mouth/eye care prn
- **Monitor for:**
 - nausea/vomiting (risk of aspiration)
 - gastric distension
 - ↓ BP
 - [Pneumothorax, p. 140](#)

Laryngeal mask airway (LMA) insertion

LMA - adult/child

Instructions for i-gel® supraglottic airway¹ (concept is similar for other LMAs - check first)

- See i-gel training and guidance videos <https://au.intersurgical.com/info/igel-videos>
- Select appropriate i-gel size
- Lubricate back, sides + front of cuff with thin layer of lubricant
- If using i-gel O₂® check supplementary O₂ port is capped²

Age	i-gel® size
Neonate 2–5 kg	1.0
Infant 5–12 kg	1.5
Child 10–25 kg	2.0
25–35 kg	2.5
Adult 30–60 kg	3
50–90 kg	4
90+ kg	5

If adult and no c-spine injury suspected, extend head with neck flexed¹



- Grasp i-gel along the bite block + position so that the cuff outlet is facing towards the chin
- Place patient's head in the 'sniffing position'
- Open the mouth by gently pressing the chin
- Introduce soft tip into the mouth towards hard palate
- Glide i-gel downwards + backwards along hard palate with a continuous but gentle push until a definitive resistance is felt
- No need to insert fingers into patient's mouth
- **Do not apply excessive force**
- A black line across the bite block indicates approx. position of teeth when positioned correctly
- The tip of the i-gel should be located in the upper oesophageal opening (**a**) and the cuff against the laryngeal framework (**b**). The teeth resting on the bite block (**c**)
- **Secure i-gel** by taping maxilla to maxilla
- If patient no longer tolerates i-gel or unable to ventilate effectively, remove it

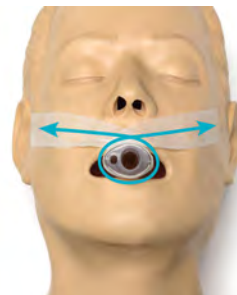
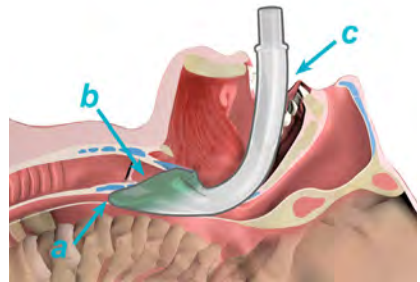

Also see Qld Ambulance Service Clinical Practice Procedure - supraglottic airway - i-gel®
<https://www.ambulance.qld.gov.au/CPPTable.html>

Images used with permission of ©Intersurgical Ltd, UK

Intraosseous access



HMP Intraosseous access - adult/child

Recommend

- Use if urgent need for fluids/medications + difficult/failed IVC access¹
- Pain from intraosseous infusion under pressure is more severe than insertion²
- **Check for contraindications:**²
 - fracture in or adjacent to the target bone
 - excessive tissue ± absence of adequate anatomical landmarks
 - infection at site
 - previous significant orthopaedic procedure at the site, prosthetic joint
 - intraosseous access/attempted access in targeted bone within last 48 hours
- **Prepare equipment + site:**
 - select site + needle set, as per **Insertion guide** (next page)^{1,2}
 - clean site using antiseptic + aseptic technique
 - **note:** lidocaine (lignocaine) is not usually needed for insertion of intraosseous needle
 - if responsive to pain, **before infusion** prime extension set with lidocaine (lignocaine) 1% approx. 1 mL (10 mg)¹
- **Insert intraosseous needle** (instructions next page)
- **Once inserted:**^{1,3}
 - place stabilising dressing over the hub
 - aspirate for blood/bone marrow. The inability to withdraw/aspirate blood does not mean unsuccessful insertion, consider re-trying after the flush
 - attach primed extension set + flush with lidocaine (lignocaine) 1% OR sodium chloride 0.9% if unresponsive
 - connect fluids. Infusion may need to be pressurised to get desired rate ie pressure bag or pump

S4	Lidocaine (lignocaine)			Prescribing guide		
MID, RIPRN and RN only. Must be ordered by an MO/NP						
Form	Strength	Route	Dose	Duration		
Injection	1% 50 mg/ 5 mL	Intraosseous	Adult 40 mg	Remember to calculate including dose in primed IV extension Give over 2 minutes, allow to dwell in intraosseous space for 1 minute, then rapidly flush with sodium chloride 0.9% child 5 mL adult 10 mL		
			Child < 16 years 0.5 mg/kg (max. 40 mg)			
			Additional half doses			
			Adult 20 mg	Give over 1 minute Repeat doses as per MO/NP max. of once in 45 minutes		
Child < 16 years 0.25 mg/kg (max. 20 mg)						
Note: Monitor for extravasation, hypersensitivity + other side effects with each injection ie dizziness, paraesthesia, nystagmus, rash, drowsiness, confusion, seizures, ↓RR, ↓HR, ↓BP						
Management of associated emergency: Consult MO/NP. See Anaphylaxis, p. 82 1,3						

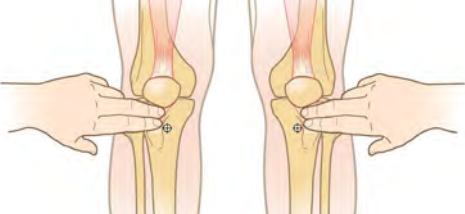
Insertion guide

<p style="text-align: center;">Needle set</p> <ul style="list-style-type: none"> • Select needle set based on patient weight, anatomy + clinical judgment 	<ul style="list-style-type: none"> • 45 mm needle set (yellow hub) proximal humerus > 40 kg + patients with excessive tissue over any insertion site • 25 mm needle set (blue hub) > 3 kg • 15 mm needle set (pink hub) approx. 3–39 kg
<p style="text-align: center;">Proximal humerus²</p> <ul style="list-style-type: none"> • Place patient's hand over the abdomen, place your palm on the shoulder anteriorly. The 'ball' under your palm is the general target area. Aim needle set tip downward at approx. 45° angle • Note: abduction of arm after placement will dislodge needle 	 <p>An illustration showing a hand placed over the shoulder of a patient. A blue crosshair marks the target area on the proximal humerus. A hand is shown holding a needle set, aiming it towards the target area at a downward angle.</p>
<p style="text-align: center;">Proximal tibia²</p> <ul style="list-style-type: none"> • Extend the leg, feel for flat aspect of tibia • Approx. 3 cm (1–2 cm in infant/child) below the patella + approx. 2 cm medial (1 cm in infant/child) to the tibial tuberosity along the flat aspect of the tibia (depending on anatomy). Aim needle set tip at a 90° angle to the bone 	 <p>Two illustrations showing the proximal tibia. The left one shows a hand palpating the tibia just below the patella. The right one shows a hand holding a needle set, aiming it perpendicular to the tibia.</p>
<p style="text-align: center;">Distal tibia²</p> <ul style="list-style-type: none"> • Approx. 3 cm (infant 1 cm/1 finger) above most prominent aspect of medial malleolus. Feel for anterior and posterior borders of tibia to assure that insertion site is in the flat centre of the bone + 90° or perpendicular to the surface of bone 	 <p>An illustration showing a hand palpating the distal tibia, specifically the area above the medial malleolus. A needle set is shown aiming perpendicular to the bone.</p>
<p style="text-align: center;">Distal femur²</p> <ul style="list-style-type: none"> • Secure site with leg outstretched to ensure knee does not bend. Feel for patella, insertion site is just proximal to superior border (max. 1–2 cm) and approx. 1–2 cm medial 	 <p>An illustration showing the distal femur. A red crosshair marks the insertion site just proximal to the superior border of the patella. A dashed line indicates the location of the growth plate. A hand is shown holding a needle set, aiming it towards the target area.</p>

Arrow EZ-IO Vascular Access System images courtesy of Teleflex

How to insert Arrow EZ-IO® device²

- Attach needle set to driver + remove safety cap
- Push needle tip through the skin until tip touches the bone:
 - before pressing the trigger, **check** at least 1 black line is visible above the skin to confirm adequate needle set length
- Gently drill. Immediately stop advancing + release the trigger when you feel a ‘pop’ or ‘give’ as the needle set enters the medullary space:
 - do **NOT** pull/jerk back on the driver when releasing the trigger
- Hold the hub + pull the driver straight off needle set. Continue to hold hub in place while twisting the stylet off with anticlockwise rotations
- **See instructions + video** at <https://www.teleflex.com/anz/en/product-areas/emergency-medicine/intraosseous-access/arrow-ez-io-system/clinical-resources/index.html>

Manual insertion

- Hold the needle set with the catheter hub and stylet as 1 piece. Ensure stylet + hub stay screwed together
- Rotate clockwise/anticlockwise while applying gentle, moderate steady downward pressure without rocking the needle set. Allow rotation + pressure to penetrate the bone cortex, not excessive force
- **Child** - stop when change of pressure or resistance felt as a ‘pop’ or ‘give’ indicating entry to medullary space
- **Adult** - advance needle set approx. 1–2 cm after entry into medullary space, which is felt as a change in resistance; in the proximal humerus for most adults the needle set should be advanced 2 cm or until hub is flush or against the skin

After insertion

- **Monitor closely + contact MO/NP if:**^{1,2}
 - intraosseous lidocaine (lignocaine) is not sufficient + the patient is still in pain:
 - MO/NP may consider systemic analgesia
 - change in patient’s response to medications
 - ↓ flow rate/alarms on infusion pump
 - fever or signs of:
 - extravasation/infiltration at site
 - [Compartment syndrome, p. 160](#) in limb

Critical emergencies

Unconscious/altered level of consciousness - adult/child

Recommend

- Unconsciousness is a medical emergency - early stability + diagnosis are vital¹
- Assume a serious cause until proven otherwise¹

1. May present with²

- Unconscious/altered level of consciousness (LOC)

2. Immediate management²

- **DRSABCD** as per [BLS, p. 46](#)
- Assist patient onto the ground/bed + position on side
- Do NOT leave sitting in a chair or put head between their knees
- Open airway - airway takes precedence over any injury:
 - handle gently, avoid twisting or forward movement of head + spine
 - use head tilt/chin lift for adult + child > 1 years
 - infant - keep head neutral
- **Call for help + contact MO/NP urgently**
- Stop any bleeding
- **Do:**
 - vital signs:
 - note pattern + regularity of breathing:¹
 - deep, laboured (Kussmaul respiration) - often associated with [DKA, p. 89](#)
 - shallow with extremely ↓ RR - seen in opioid overdose
 - hyperventilation
 - give O₂ if required to maintain SpO₂ ≥ 94%
 - BGL - if < 4 treat immediately. See [Hypoglycaemia, p. 91](#)
 - insert IVC x 2
 - neurological observations ie:³
 - [GCS, p. 562](#) - if ≤ 8 requires secured airway, consider [LMA, p. 56](#) until patient can be intubated¹
 - pupil size + reaction to light
 - motor response in limbs
 - fontanelle in infant
 - continuous cardiac monitoring + ECG
 - screen for [Sepsis, p. 64](#)
 - If hypotensive, give rapid IV sodium chloride 0.9% 10–20 mL/kg. See [Shock, p. 62](#)

3. Clinical assessment

- Do not leave patient alone if possible
- Constantly re-check for any change, including:^{2,4}
 - airway for any signs of obstruction eg:
 - laboured/noisy breathing, or no sound of breathing
 - ↑ WOB eg intercostal recession, nasal flaring in infants
 - abdomen moves in/out, but loss of natural rise of chest

- [GCS, p. 562](#) - if drops ≥ 2 points urgently contact MO/NP
- **Get rapid history** from friends/relatives or bystanders:¹
 - was the loss of consciousness witnessed
 - when/what happened prior/what were they doing
 - prior headache/chest pain/other symptom
 - ingestions, IV drug use
 - trauma
 - seizures/abnormal movements
- **Look for clues/causes eg:**¹
 - trauma
 - signs of stroke
 - overdose eg suicide note, empty medicine packet(s), needle + syringe
 - if suspected opioid give [naloxone, p. 221](#)
 - see [Toxicology assessment, p. 212](#)
 - alcohol or substance/drug use
 - **note:** if alcohol intoxication suspected, continue to look for other causes¹
 - infection, especially the elderly
 - bruising/minor injuries
 - snake bite/other envenomation. If suspected see [Bites and stings, p. 222](#)
 - indications of known allergies eg jewellery/accessory eg key ring, USB stick, shoe tag, anklet, watch, tattoo

Possible causes of altered LOC ¹	
Neurological	Metabolic
<ul style="list-style-type: none"> • Head injury/trauma, consider non-accidental injury in child • Stroke • Seizure/post seizure • Meningitis, encephalitis • Epilepsy • Tumour 	<ul style="list-style-type: none"> • Hypo/hyperglycaemia • Intoxication - alcohol, inhalants • Poisoning or overdose • Sepsis • Electrolyte derangement • Encephalopathy • Liver failure, kidney failure
Low oxygen/hypoxia	Heart + circulation
<ul style="list-style-type: none"> • Airway obstruction, respiratory failure • Choking/foreign body • Allergy/anaphylaxis • Croup/epiglottitis • Asthma/COPD • Burns • Toxic gas/smoke/steam inhalation • Drowning/near drowning • Pneumonia • PE, pulmonary oedema 	<ul style="list-style-type: none"> • Hypotension • Trauma/haemorrhage • GI bleed • Ectopic pregnancy • Ruptured aortic aneurysm • Cardiac arrest/arrhythmia • Intracranial haemorrhage • Hypo/hyperthermia

- **Get past history** as able (from relatives/friends/medical records):
 - known underlying illness eg epilepsy, diabetes, cancer
 - allergies
 - medications eg anticoagulants
 - recent surgery/hospitalisation

- **Do physical examination**, including:¹
 - urinalysis + pregnancy test if female of reproductive age
 - listen to chest - any wheeze, crackles
 - head to toe examination - check for:
 - any odour eg fruity sweet smelling breath. **Note:** acetone - similar to paint thinner or nail polish remover - may indicate [DKA, p. 89](#)
 - skin eg rash, drug injection sites, puncture wounds
 - remove all clothing as you move down, maintain privacy + keep patient warm
- **Take bloods/i-STAT:**¹
 - FBC, lactate, glucose, UE, calcium, LFT, coagulation studies
 - toxicology screen including paracetamol, salicylate + blood alcohol level

4. Management

- Ongoing management as per MO/NP, which may include:
 - chest x-ray, eFAST (if trained/available)
 - evacuation + treatment according to suspected cause

5. Follow up

- According to possible cause - as per MO/NP

6. Referral/consultation

- As above

Shock - adult/child

Background

- Shock is a loss of effective circulation resulting in impaired tissue oxygen + nutrient delivery and causes life-threatening organ failure. Any seriously ill or seriously injured patient is at risk of developing shock¹
- Causes include - sepsis, anaphylaxis, major haemorrhage, large fluid loss + rarely obstruction of cardiac outflow + cardiogenic failure¹

1. May present with^{1,2}

- **Signs of shock:**
 - ↓ LOC
 - ↓ perfusion - mottled or pale skin, cool extremities, capillary refill > 2 seconds ± clammy
 - ↑ HR, ↑ RR

2. Immediate management

- **DRSABCD**
- Call for help + urgently contact MO/NP when able
- If signs of shock + suspected anaphylaxis:
 - give IM adrenaline (epinephrine) 1:1,000 (see [Anaphylaxis, p. 82](#) for doses)
 - repeat every 5 minutes if needed
- Lie the person down, if unconscious place on side¹
- **Start resuscitation**
- Give O₂ 15 L/minute via non-rebreather mask^{1,2}

- Insert IVC x 2 eg 18 G or **Intraosseous**, p. 57 if 2 failed attempts
 - take bloods/i-STAT - VBG, lactate, UE, glucose. **Note:** if lactate > 2 inform MO/NP
- **Rapidly give bolus IV sodium chloride 0.9%:**²⁻⁴
 - **adult** 250–500 mL, **child** 20 mL/kg
 - reassess + repeat if no improvement in HR, LOC or perfusion
- If persisting signs of shock after fluid bolus x 2 - urgently contact MO/NP +
 - consider **Sepsis**, p. 64 if suspected or no other cause of shock identified, initiate sepsis pathway + give broad spectrum antibiotics^{2,3}
- Monitor:
 - vital signs, **GCS**, p. 562, capillary refill time
- Continuous cardiac monitoring²
- Look for cause of shock:
 - haemorrhage eg:
 - **Ectopic pregnancy**, p. 371 - do pregnancy test
 - **Traumatic injuries**, p. 134
 - **note:** if haemorrhagic shock MO/NP may order **Tranexamic acid**, p. 139 - give within 3 hours
 - **Upper GI bleeding**, p. 203, **Button battery**, p. 80, **Rectal bleeding**, p. 204
 - large fluid loss eg **Gastroenteritis** - adult, p. 200 or **Gastroenteritis** - child, p. 535
 - sepsis/septic shock, anaphylaxis, brain/spinal injuries
 - cardiac dysfunction³ eg **ACS**, p. 107
 - blockage of blood flow in/around the heart eg **PE**, p. 125

3. Clinical assessment

- Get rapid history, ask about:
 - recent illness, nausea/vomiting, diarrhoea
 - decreased urine output
 - immunocompromised
 - underlying conditions eg cancer, heart disease, diabetes
 - any medications
 - recent drugs or alcohol
- Do physical assessment, including:
 - listen to chest - any wheeze, crackles
 - ECG - send for urgent review by MO/NP
 - urinalysis
 - check skin - any rash, wounds, bruising
 - abdomen:
 - listen to bowel sounds - present/absent - if absent, consider **Bowel obstruction**, p. 205
 - palpate for any tenderness, guarding, rigidity, rebound tenderness, masses

4. Management

- Ongoing management as per MO/NP + likely cause of shock

5. Follow up

- As per MO/NP

6. Referral/consultation

- As above

HMP Sepsis/septic shock - adult/child

Recommend

- Sepsis is a medical emergency - early recognition + rapid treatment is imperative for survival. Consider in every patient with fever or acute illness^{1,2}
- Initial presentation can be vague. Always have a high index of suspicion in neonates, young infants, the elderly and immunocompromised patients
- If suspected sepsis - initiate treatment + investigations until sepsis has been excluded
- Use rural + remote sepsis pathways:
 - **adult** <https://clinicalexcellence.qld.gov.au/priority-areas/safety-and-quality/sepsis/sepsis-resources/adult-sepsis-pathways>
 - **child** <https://www.childrens.health.qld.gov.au/chq/health-professionals/sepsis/>
 - if outside of Qld use local pathways

Background

- Sepsis = infection + organ dysfunction^{1,2}
- Children can have sepsis with normal BP. Hypotension is a late sign of shock
- Neonates + infants < 1 year are at highest risk as immature immune systems are unable to ward off severe infections
- Elevated lactate > 2 may indicate the severity of sepsis + is used to follow the therapeutic response

1. May present with

Screen ALL patients for sepsis if ANY of the following:^{1,2}

- Looks sick/toxic, may report 'the worst I've ever felt'
- You suspect they may have sepsis
- Has a suspected infection
- Unexplained severe pain or restlessness in children
- Patient, family or carer/parent has concerns
- Signs of clinical deterioration eg Q-ADDS or CEWT score ≥ 4
- Fever or hypothermia - $T < 35.5$
- Altered behaviour, confusion OR ↓ LOC
- < 3 months

2. Immediate management^{1,2}

- Do vital signs, including BP +
 - conscious level - AVPU, p. 562
 - BGL
 - weight - bare weight if < 2 years
- **If ≥ 16 years** - check for ANY Risk factors for sepsis
- **If < 16 years** - go to **Step 1 - Check for ANY features of severe illness**
- For paediatric oncology patients use the clinical pathway *Initial management of suspected neutropenic sepsis* https://qheps.health.qld.gov.au/__data/assets/pdf_file/0026/2629700/SW796_v2.00_032021.pdf

Risk factors for sepsis²

- Aboriginal and Torres Strait Islander, Pacific Islander or Maori
- Chronic disease eg diabetes or congenital condition
- Malnourished or frail
- Indwelling medical device
- Recent trauma or surgery, invasive procedure, wound - < 6 weeks
- Postpartum/miscarriage
- IV drug use or alcoholism
- Re-presentation within 48 hours
- Immunocompromised, asplenia, neutropenia, unimmunised:
 - T \geq 38.5 x 1 OR 38 x 2 - 1 hour apart AND suspected neutropenia OR chemotherapy given < 2 weeks, **suspect febrile neutropenia**
 - + use local guideline if available**, if not - continue screening

AND/OR

- Is there any reason to suspect an infection - respiratory tract, urinary, abdomen/GIT, skin/joint/prosthesis, central venous access device/PICC line, CNS/meningitis, new onset confusion, family members suspect infection, source unclear at present

YES

NO

Go to **Step 2 - check for any features of moderate illness** (next page)

Step 1. Check for ANY features of severe illness**Child < 16 years**

- Needs O₂ to keep SpO₂ \geq 92%
- Severe respiratory distress/tachypnoea/apnoea (CEWT respiratory score 3)
- Severe tachycardia or bradycardia (CEWT HR score 3)
- Hypotension (CEWT BP score \geq 2)
- Lactate \geq 2 if known
- Altered AVPU
- Non-blanching rash
- Hypothermia (CEWT temperature score 2)
- Capillary refill \geq 3 seconds
- Parental/clinician concern
- Cold extremities

 \geq 16 years–adult

- Systolic BP < 90 (or drop > 40 from normal)
- Lactate \geq 2 if known
- Non-blanching rash/mottled ashen/cyanotic
- RR \geq 25
- Needs O₂ to keep SpO₂ \geq 92%
- HR \geq 130
- Evidence of new or altered mental state
- Not passed urine in 18 hours
- Recent chemotherapy

NO

ANY features of severe illness

Go to **Step 2 - check for any features of moderate illness** (next page)

YES

Patient HAS sepsis or septic shock until proven otherwise
Consult MO urgently
See Step 3 (next page)

Step 2. Check for ANY features of moderate illness

Child < 16 years ¹	≥ 16 years–adult ²
<ul style="list-style-type: none"> Moderate respiratory distress/tachypnoea (CEWT respiratory score 2) Moderate tachycardia (CEWT HR score 2) Unexplained pain or restlessness Low BGL Reduced urine output 	<ul style="list-style-type: none"> RR 21–24 HR 90–129 OR new dysrhythmia Systolic BP 90–99 Not passed urine in last 12–18 hours T < 35.5 or ≥ 38.5 Relatives concerned about mental state Acute deterioration in functional ability

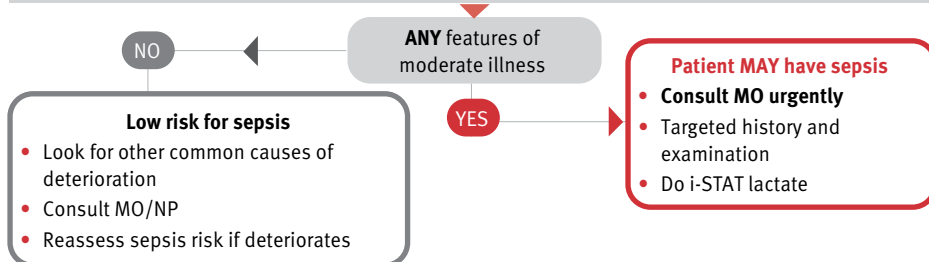

Step 3: If ANY indications this is likely sepsis or septic shock^{1,2}

- Call for help
- Consult MO urgently:**
 - senior MO to diagnose sepsis where possible
 - arrange early evacuation
 - use sepsis rural + remote pathways if available
- Maintain SpO₂ ≥ 94%** (88–92% if COPD). Give O₂ if needed
- Insert IVC x 2 or Intraosseous, p. 57** if 2 failed attempts
- Do lactate**
- Take bloods** unless this will delay antibiotics > 1 hour:
 - < 16 years:**
 - blood cultures - aim for 2–6 mL (1 aerobic bottle)
 - lactate/VBG + FBC. If possible add CHEM20 or LFT, UEG, CMP, CRP
 - BGL
 - ≥ 16 years–adult:**
 - blood cultures - 2 sets from 2 sites (2 sets of aerobic + anaerobic bottles)
 - lactate, FBC, UEC, BGL, LFT, lipase, VBG
 - if septic shock add coagulation studies
- Check allergies**
- Give IV/intraosseous antibiotics within 1 hour - do not delay:**
 - local patterns of resistance to be considered
 - target to source of infection if known
 - use sepsis rural + remote pathways for guidance
 - give antibiotics with shorter infusion times first
 - note:** MRSA infection risks - chronic underlying disease eg renal failure, diabetes, immunosuppression, chronic wounds or dermatitis, living in close quarters or communities with high MRSA prevalence, known colonisation with MRSA

Empirical antibiotics - if unknown source + not allergic MO/NP may order

- **< 2 months:**¹
 - cefotaxime PLUS ampicillin
 - if at risk of MRSA ADD vancomycin
- **2 months–16 years:**¹
 - cefotaxime
 - if at risk of MRSA ADD vancomycin
- **If child has septic shock/critically ill REPLACE above with:**¹
 - cefotaxime PLUS gentamicin PLUS vancomycin
- **> 16 years–adult:**²
 - gentamicin PLUS flucloxacillin
 - if at risk of MRSA ADD vancomycin
 - if meningitis cannot be excluded ADD ceftriaxone. See [Meningitis, p. 72](#)

If timely IV/intraosseous access not possible - IM route can be used for most antibiotics

Guidelines for max. mL for IM injection					
Muscle	0–18 months	18 months–3 years	3–6 years	6–15 years	> 15 years
Vastus lateralis	0.5 mL	1 mL	1.5 mL	1.5–2 mL	2–2.5 mL
Deltoid	Not recommended	*0.5 mL	0.5 mL		1 mL
Ventrogluteal		*1 mL	1.5 mL	1.5–2 mL	2–2.5 mL
*Gluteus maximus		1 mL	1.5 mL	1.5–2 mL	2–2.5 mL
*Not recommended if other sites are available					
Volumes of up to 2.4 mL in 1 injection are used in exceptional circumstances with documented informed consent where the risk of muscle necrosis is discussed with the patient/carer					

Additional considerations ALL ages^{1,2}

- During November to May (tropic wet season) - areas north of Mackay, Tennant Creek, Port Hedland:
 - **< 16 years** - follow empirical antibiotic recommendations above based for age + risk factors. Contact MO urgently to review clinical status + revise antibiotics according to the Qld paediatric sepsis pathway <https://www.childrens.health.qld.gov.au/chq/health-professionals/sepsis/>
 - **> 16 years** - MO may consider replacing antibiotic regimen above with meropenem AND vancomycin
 - for patients with significant underlying conditions who are known to be colonised with antibiotic-resistant organisms, follow empirical antibiotic recommendations above, but contact MO or infectious diseases urgently for advice
- If meningitis cannot be excluded, see [Meningitis, p. 72](#) for empirical antibiotic choices
- If encephalitis suspected ADD aciclovir. See [Meningitis, p. 72](#)

MO/NP may order IV/intraosseous sodium chloride 0.9%

- **< 16 years:**¹
 - give rapid fluid bolus 10–20 mL/kg
 - observe for hepatomegaly (enlarged liver)
 - assess response including HR, perfusion, lactate, LOC
 - MO/NP may order:
 - repeat up to 40–60 mL/kg within 1st hour
 - if hypoglycaemic - 2 mL/kg glucose 10%

- **≥ 16 years—adult:**²
 - consider weight, cardiac function, comorbidities + current volume status
 - give rapid fluid bolus 250–500 mL over 5 minutes if clinically indicated
 - assess response + give further bolus if indicated
 - further IV fluids on MO/NP orders (do not exceed 30 mL/kg without senior MO input)

3. Clinical assessment^{1,2}

- Ask about recent history of:
 - illness, operations/hospitalisation, postpartum, skin infections
 - antimicrobial use within the last 3 months - which one(s), what for
 - travel - where to/when
- Past history - diabetes, immunosuppressive medications, chemotherapy
- Ask about/look for source of infection, **note:** source might be unclear:
 - cough, sputum, breathlessness - pneumonia is the most common cause of sepsis
 - listen to chest for:
 - air entry
 - crackles or wheeze
 - dysuria, frequency:
 - do urinalysis + MSU for MCS + pregnancy test if possible
 - abdominal pain, distension
 - listen for bowel sounds - paralytic ileus may be present
 - cellulitis, septic arthritis, infected wound, device related infection
 - neck stiffness, photophobia, non-blanching rash, new onset confusion, headache, vomiting, nausea. See [Meningitis, p. 72](#)
- Check all skin surfaces for:
 - bruising/bleeding
 - rash at pressure points + under clothing. **Note:** petechiae + purpura do not fade on pressure
- Check vaccination status

4. Management^{1,2}

- Reassess + monitor response to resuscitation:
 - re-check lactate - aiming for < 2
 - do frequent:
 - vital signs - aiming for sBP in adult ≥ 100
 - capillary refill time
 - [AVPU, p. 562](#)
- Monitor fluid balance + urine output aiming for:
 - > 1 mL/kg for < 16 years/child
 - > 0.5 to 1.0 mL/kg/hour for ≥ 16 years/adult
 - consider IDC as appropriate

If no or limited improvement MO may consider:

- **< 16 years** - inotropes (on ICU specialist advice):
 - adrenaline (epinephrine) infusion - use 1 mL of 1:1000 adrenaline (epinephrine) (1 mg/mL). Mix with 49 mL glucose 5% for final concentration 0.02 mg/mL
 - infuse at 0.05–0.5 microg/kg/minute
- **≥ 16 years—adult** - vasopressors for hypotension:
 - noradrenaline (norepinephrine) 5 microg/minute

MO will urgently seek specialist/RSQ advice if patient STILL has:

- Persistent tachypnoea, hypotension, tachycardia
- Lactate ≥ 2 - adult + child
- Altered LOC despite resuscitation
- If patient critically ill at any time

S4	Cefotaxime			Extended authority ATSIHP/IHW	
ATSIHP, IHW, RIPRN and RN must consult MO/NP					
Form	Strength	Route	Dose	Duration	
Injection	1 g 2 g	<p>IV/Intraosseous</p> <p>Reconstitute 1 g vial with 9.6 mL water for injections to give concentration of 100 mg/mL</p> <p>OR</p> <p>2 g vial: add 9 mL water for injections to give concentration of 200 mg/mL</p> <p>THEN</p> <p>Dilute dose with sodium chloride 0.9% to concentration of 150 mg/mL or weaker</p>	<p>Infant and child</p> <p>≤ 16 years</p> <p>50 mg/kg (max. 2 g)</p>	<p>stat</p> <p>IV/Intraosseous</p> <p>Inject slowly over at least 3–5 minutes</p>	
		<p>IM</p> <p><i>Can be given IM but is extremely painful</i></p> <p>Reconstitute 1 g vial with 2.6 mL OR 2 g vial with 5 mL water for injections to give concentration of 330 mg/mL</p>		<p>IM Child</p> <p>See Guidelines for max. mL for IM injection, p. 67</p> <p>Adult</p> <p>Inject deep into gluteal muscle. If volume > 4 mL divide + give in multiple sites</p>	
<p>Offer CMI: May cause diarrhoea, nausea, vomiting, pain at injection site, rash, headache or dizziness. Can cause severe diarrhoea (colitis) due to <i>C. difficile</i></p>					
<p>Note: Rapid IV injection < 1 minute can cause life-threatening arrhythmias</p>					
<p>Contraindication: Severe hypersensitivity to penicillins, carbapenems and cephalosporins. Do not mix with aminoglycosides eg gentamicin</p>					
<p>Management of associated emergency: Consult MO/NP. See Anaphylaxis, p. 82</p>					1,3,4

S4	Ampicillin			Extended authority ATSIHP/IHW	
ATSIHP, IHW, RIPRN and RN must consult MO/NP					
Form	Strength	Route	Dose	Duration	
Injection	500 mg 1 g	<p>IV</p> <p>500 mg vial: add 4.7 mL water for injections (OR 1 g vial with 9.3 mL) to give concentration of 100 mg/mL</p>	<p>Neonate and infant</p> <p>< 2 months</p> <p>50 mg/kg (max. 2 g)</p>	<p>stat</p> <p>IV</p> <p>Inject dose < 1 g over 3–5 minutes, otherwise over 10–15 minutes</p>	
		<p>IM</p> <p>500 mg vial: add 1.7 mL water for injections (OR 1 g vial with 3.3 mL) to give concentration of 250 mg/mL</p>		<p>IM</p> <p>See Guidelines for max. mL for IM injection, p. 67</p>	
<p>Offer CMI: May cause rash, diarrhoea, nausea and pain at the injection site</p>					
<p>Contraindication: Severe hypersensitivity to penicillins, carbapenems and cephalosporins. Do not mix with aminoglycosides eg gentamicin</p>					
<p>Management of associated emergency: Consult MO/NP. See Anaphylaxis, p. 82</p>					5

S4	Vancomycin			Extended authority ATSIHP/IHW/IPAP
ATSIHP, IHW, IPAP, RIPRN and RN must consult MO/NP				
Form	Strength	Route	Dose	Duration
Injection	500 mg 1 g	IV/Intraosseous Reconstitute 500 mg vial with 10 mL of water for injections (20 mL to 1 g) to give concentration of 50 mg/mL THEN Dilute dose in sodium chloride 0.9% to make concentration of at least 5 mg/mL CANNOT be given IM	> 1 month 15 mg/kg (max. 750 mg) > 16 years to adult 30 mg/kg loading dose Use Actual <i>Body Weight</i>	stat IV/Intraosseous Infuse over at least 60 minutes Max. rate for doses over 500 mg is 10 mg/minute
		Note: Use see eTG for subsequent dosing or dosing in obese adults. Give through securely fastened IVC as extravasation may cause tissue necrosis. Do not infuse faster than recommended rate - can cause severe reactions ie profound hypotension + 'red-man syndrome' eg fever, chills, erythema, facial + upper torso rash, may be followed by hypotension, angio-oedema + itch. If 'red-man syndrome' decrease/stop infusion + contact MO/NP		
Management of associated emergency: Consult MO/NP. See Anaphylaxis, p. 82				6

S4	Flucloxacillin			Extended authority ATSIHP/IHW/IPAP
ATSIHP, IHW, IPAP, RIPRN and RN must consult MO/NP				
Form	Strength	Route	Dose	Duration
Injection	500 mg 1 g	IV/Intraosseous Reconstitute 500 mg vial with 10 mL OR 1 g vial with 15–20 mL water for injections	> 16 years to adult 2 g	stat IV/Intraosseous Inject slowly over 6–8 minutes IM Inject deep into large muscle. No more than 1 g in each site
		IM Reconstitute 500 mg vial with 2 mL (1 g vial with 2.5 mL) water for injections OR lidocaine (lignocaine) 1%		
Offer CMI: May cause diarrhoea, nausea and pain at the injection site				
Note: Rapid IV injection may cause seizures				
Contraindication: Severe hypersensitivity to penicillins, carbapenems and cephalosporins				
Management of associated emergency: Consult MO/NP. See Anaphylaxis, p. 82				7

S4	Meropenem			Prescribing guide	
RIPRN and RN only. Must be ordered by an MO/NP					
Form	Strength	Route		Dose	Duration
Injection	1 g	IV/Intraosseous Reconstitute with 20 mL water for injections Shake well before use		> 16 years to adult 1 g	Inject over 5 minutes
Offer CMI: May cause nausea, vomiting, headache or phlebitis of IVC site					
Note: Risk of seizures - use cautiously if CNS infections, renal dysfunction or history of seizure disorders. Not for IM injection					
Contraindication: Severe hypersensitivity to penicillins, carbapenems and cephalosporins					
Management of associated emergency: Consult MO/NP. See Anaphylaxis, p. 82 8					

S4	Gentamicin			Extended authority ATSIHP/IHW/IPAP	
ATSIHP, IHW, IPAP, RIPRN and RN must consult MO/NP					
Form	Strength	Route	Dose	Duration	
Injection	10 mg/mL 80 mg/2 mL	IV/ Intraosseous Child Dilute with sodium chloride 0.9% to convenient volume (ie to 10 mg/mL or weaker) Adult Dilute to 20 mL with sodium chloride 0.9% to enable slow injection if required	Term neonate ≤ 1 month 5 mg/kg Child > 1 month to < 10 years 7.5 mg/kg (max. 320 mg) Child 10 years to < 16 years 6 mg/kg (max. 560 mg) OR if critically ill/septic shock 7 mg/kg (max. 640 mg)	IV/Intraosseous Child Infuse over 20–30 minutes Adult Inject slowly over 3–5 minutes	
		IM	≥ 16 years to adult 5 mg/kg IBW/AdjBW (max. 500 mg) OR for septic shock 7 mg/kg IBW/AdjBW (max. 700 mg)	IM Child See Guidelines for max. mL for IM injection, p. 67 Adult Inject into large muscle. No more than 4 mL at each site	
Note: Rapid IV injection may result in ototoxicity/vestibular toxicity. IV gentamicin is inactivated by cephalosporins + penicillins. Flush line well before giving gentamicin or give at separate sites to prevent inactivation. Adult - dose according to Ideal Body Weight (IBW) or actual body weight, which ever is less. Where actual body weight is > 20% of IBW, use Adjusted Body Weight (AdjBW). For adjusted dosing calculations or with known or likely pre-existing renal impairment see eTG or <i>Aminoglycoside dosing in adults</i> (May 2018) https://www.health.qld.gov.au/__data/assets/pdf_file/0019/713323/aminoglycoside-guidelines.pdf Can be given as a single dose in adults with sepsis, regardless of age. Child - use IBW to calculate dose, unless actual body weight is lower. If > 20% over IBW use IBW. Determine IBW by using corresponding weight for height percentile on a growth chart https://www.rch.org.au/childgrowth/about_child_growth/Growth_charts/					
Contraindication: Previous vestibular/auditory toxicity with aminoglycosides, severe allergic reaction to aminoglycoside, myasthenia gravis. Use with caution if > 80 years, pre-existing vestibular/auditory impairment, renal impairment/rapidly changing function, other nephrotic agents					
Management of associated emergency: Consult MO/NP. See Anaphylaxis, p. 82 9					

5. Follow up

- As per MO/NP

6. Referral/consultation

- Urgent treatment + evacuation/hospitalisation required
- Further doses of antibiotics required in 6–8 hours - contact MO/NP if still waiting to be evacuated

HMP Meningitis - adult/child

Recommend

- Meningitis is a medical emergency. Early recognition + treatment is imperative^{1,2}
- If suspected, but lumbar puncture cannot be done \leq 30 minutes, give IV antibiotics^{1,2}
- Do NOT use hyponatraemic solutions eg glucose 4% with sodium chloride 0.18% or sodium chloride 0.45% - ↑ risk of cerebral oedema
- Suspect meningitis if sick child with no obvious source of infection
- Parents/carers may notice early, subtle changes in child's LOC - do not ignore their concerns
- Meningococcal infection is a notifiable disease ⓘ **notify Public Health Unit within 6 hours**

Background

- Children often present with non-specific symptoms and not the classic triad of fever, headache + neck stiffness²
- Meningitis is an inflammation or infection of the membranes that surround the brain + spinal cord. It can lead to serious long-term neurological complications + death
- Viral meningitis is more common than bacterial meningitis, but is usually less severe

1. May present with¹

- Typically presents with acute history of fever, neck stiffness + altered conscious state ±
 - headache, photophobia + nausea or vomiting - often prominent¹
 - petechial rash - very late sign + indicative of meningococcal sepsis
 - focal neurological deficit, seizures, shock
- Older children may present with any combination of the above² ±
 - upper or lower respiratory tract symptoms, myalgia + abdominal pain
- < 3 months - bulging fontanelle, high pitched cry, poor feeding, apnoea, seizures, vomiting²

2. Immediate management

- If fitting see [Fitting, p. 86](#) for midazolam dosing
- **Consult MO/NP urgently**
- Get rapid history + manage concurrently
- Do vital signs +
 - central capillary refill time
 - [GCS, p. 562](#)
 - BGL
- **Give O₂** to maintain SpO₂ \geq 94%
- **Insert IVC x 2 or Intraosseous, p. 57** if 2 failed attempts

- **Take bloods** unless this will delay antibiotics > 30 minutes:²⁻⁴
 - meningococcal PCR (adult 4 mL in mauve top tube; child 1 mL in EDTA pink top tube)
 - VBG, FBC, coagulation studies, LFT, UE, glucose
 - blood cultures:
 - if < 16 years - aim for 2–6 mL (1 aerobic bottle)
 - if > 16 years or adult - 2 sets from 2 sites (2 sets of aerobic + anaerobic bottles)
- **Correct BGL if needed:**
 - give glucose 10% 2 mL/kg - as per MO/NP²
- Check allergies
- **MO/NP will order antibiotics - give within 30 minutes - DO NOT DELAY**
- If child > 3 months + adult, give dexamethasone before or with 1st dose of antibiotic²
- If not allergic, MO/NP may order:^{3,4}
 - **neonate + infant < 2 months:**
 - ampicillin PLUS cefotaxime
 - **child ≥ 2 months + adult:**
 - ceftriaxone OR cefotaxime
 - if critically ill immunocompetent child ≥ 2 months MO/NP may ADD:
 - gentamicin PLUS vancomycin. See [Sepsis, p. 64](#) for dosing
 - if herpes simplex encephalitis suspected MO/NP may ADD aciclovir
 - if immunocompromised, > 50 years old, history of heavy alcohol consumption, pregnant or debilitated, to cover listeria MO/NP may ADD:
 - benzylpenicillin
- IM route can be used if timely IV/intraosseous access not possible
- **Start fluid resuscitation** as clinically indicated ≤ 30 minutes:²⁻⁴
 - give sodium chloride 0.9% 20 mL/kg fluid bolus
 - repeat if needed as per MO/NP
- Arrange urgent evacuation
- Consider [Sepsis, p. 64](#) as a differential diagnosis

3. Clinical assessment

- **Note:** apparent explanation for fever (eg pharyngitis, UTI or otitis media) does not rule out diagnosis²
- **Ask about:**
 - headache, irritability, fever, rash, neck stiffness, lethargy, confusion¹
 - immunisations - Hib, meningococcal, pneumococcal + check vaccination status
 - prior use of oral antibiotics (may modify clinical features)
- **Check for risk factors:**²
 - recent contact with a case of bacterial meningitis (especially in family)
 - recent contact with HSV 'cold sores' or confirmed enterovirus infection
 - recent overseas travel
 - maternal Group B Strep (GBS) colonisation if < 3 months
 - immunocompromised
 - recent neurosurgical procedure, penetrating head injury, ventriculoperitoneal (VP) shunt, cochlear implant
- **Weight** - bare weight if < 2 years
- **Do physical examination,** including:
 - listen to chest for air entry - any crackles, wheeze

- skin for rashes including at pressure points + under nappies/clothing:
 - petechiae or purpura (do not fade on pressure)
 - **note:** if child, rash may not appear until child is rehydrated²
- Hydration assessment - adult, p. 200 or child, p. 535
- ENT
- fontanelle in infants - any fullness, bulging
- **neck stiffness:**
 - with patient lying down, put hand behind head + gently raise
 - **note:** may not complain of neck stiffness, but with passive or active flexion - cannot touch chin to chest
- +ve Brudzinski's sign - reflex flexion of the hip + knee when the neck is passively flexed **OR**
- +ve Kernig's sign - pain along spinal cord ± resistance to knee extension when hip and knee are flexed to 90°
 - may indicate bacterial meningitis²

4. Management

- **Child** - use Qld paediatric sepsis rural and remote pathway <https://clinicalexcellence.qld.gov.au/priority-areas/safety-and-quality/sepsis/sepsis-resources/paediatric-sepsis-pathways> **AND**
 - also see *Meningitis - emergency management in children* <https://www.childrens.health.qld.gov.au/qpec-statewide-guidelines/>
 - careful management of fluid + electrolyte balance is important - discuss with paediatrician as soon as possible
- **Adult** - use Qld adult sepsis rural and remote pathway <https://clinicalexcellence.qld.gov.au/priority-areas/safety-and-quality/sepsis/sepsis-resources/adult-sepsis-pathways>
- Monitor closely until evacuation:
 - vital signs + BGL
 - give analgesia + antiemetic as needed
 - fluid balance
- Check timing of further antibiotic doses if evacuation is delayed/prolonged - contact with MO/NP

S ₄	Dexamethasone		Extended authority ATSIHP/IHW/IPAP/RIPRN	
ATSIHP, IHW, IPAP and RN must consult MO/NP				
RIPRN must consult MO/NP unless circumstances do not allow, in which case notify the MO/NP as soon as circumstances allow				
Form	Strength	Route	Dose	Duration
Injection	8 mg/2 mL 4 mg/mL	IV/Intraosseous Dilute in 10 mL sodium chloride 0.9%	Adult 10 mg	stat IV/Intraosseous Inject slowly over 3–5 minutes
		IM	Child > 3 months 0.15 mg/kg (max. 10 mg) only give IV route	IM Inject into gluteal muscle
Offer CMI: May cause transient perineal itching or burning				
Note: Give before or with first dose of antibiotic as benefit lost if given after first dose. Do not delay antibiotics if dexamethasone not available				
Contraindication: The vial formulation in patients with a known hypersensitivity to sulphites				
Management of associated emergency: Consult MO/NP. See Anaphylaxis, p. 82				2,5

S4	Ampicillin			Extended authority ATSIHP/IHW/IPAP	
ATSIHP, IHW, IPAP, RIPRN and RN must consult MO/NP					
Form	Strength	Route	Dose	Duration	
Injection	500 mg 1 g	<p>IV</p> <p>Reconstitute 500 mg vial with 4.7 mL water for injections (OR 1 g vial with 9.3 mL) to give a concentration of 100 mg/mL</p>	<p>Neonate and infant < 2 months</p> <p>50 mg/kg (max. 2 g)</p>	<p>stat</p> <p>IV</p> <p>Inject dose < 1 g over 3–5 minutes.</p> <p>Otherwise infuse over 10–15 minutes</p>	
		<p>IM</p> <p>Reconstitute 500 mg vial with 1.7 mL water for injections (OR 1 g vial with 3.3 mL) to give a concentration of 250 mg/mL</p>		<p>IM</p> <p>See Guidelines for max. mL for IM injection, p. 67</p>	
Offer CMI: May cause rash, diarrhoea, nausea and pain at injection site					
Contraindication: Severe hypersensitivity to penicillins, carbapenems and cephalosporins. Do not mix with aminoglycosides eg gentamicin					
Management of associated emergency: Consult MO/NP. See Anaphylaxis, p. 82					

6

S4	Cefotaxime			Extended authority ATSIHP/IHW	
ATSIHP, IHW, RIPRN and RN must consult MO/NP					
Form	Strength	Route	Dose	Duration	
Injection	1 g 2 g	<p>IV/Intraosseous</p> <p>Adult/2 g dose</p> <p>Reconstitute with 20 mL water for injections</p>	<p>Adult</p> <p>2 g</p> <p>Neonate and child</p> <p>50 mg/kg (max. 2 g)</p>	<p>stat</p> <p>IV/Intraosseous</p> <p>Inject slowly over at least 3–5 minutes</p>	
		<p>Child/part dose</p> <p>Reconstitute 1 g vial with 9.6 mL water for injections to give a concentration of 100 mg/mL</p> <p>OR</p> <p>2 g vial with 9 mL water for injections to give a concentration of 200 mg/mL</p> <p>THEN</p> <p>Dilute dose with sodium chloride 0.9% to a concentration of 150 mg/mL or weaker</p>		<p>IM</p> <p>Child</p> <p>See Guidelines for max. mL for IM injection, p. 67</p>	
		<p>IM</p> <p><i>Can be given IM but is extremely painful*</i></p> <p>Reconstitute 1 g vial with 2.6 mL OR</p> <p>2 g vial with 5 mL water for injections to give a concentration of 330 mg/mL</p>		<p>Adult</p> <p>Inject deep into gluteal muscle. If volume > 4 mL divide + give in multiple sites</p>	
Offer CMI: May cause diarrhoea, nausea, vomiting, pain at injection site, rash, headache or dizziness. Can cause severe diarrhoea (colitis) due to <i>C. difficile</i>					
Note: Rapid injection < 1 minute can cause life-threatening arrhythmias. *If IM is required ceftriaxone is the preferred agent					
Contraindication: Severe hypersensitivity to penicillins, carbapenems and cephalosporins. Do not mix with aminoglycosides eg gentamicin					
Management of associated emergency: Consult MO/NP. See Anaphylaxis, p. 82					

7,8

S ₄	Ceftriaxone			Extended authority ATSIHP/IHW/IPAP/RIPRN	
ATSIHP, IHW, IPAP and RN must consult MO/NP					
RIPRN must consult MO/NP unless circumstances do not allow, in which case notify the MO/NP as soon as circumstances allow					
Form	Strength	Route		Dose	Duration
Injection	1 g	IV/Intraosseous Adult Reconstitute 2 g with water for injections 40 mL		Adult 2 g	stat
		Child/part dose Reconstitute with water for injections 9.4 mL to give a concentration of 100 mg/mL If giving via infusion, dilute further in 40 mL sodium chloride 0.9%			Child > 1 months 50 mg/kg (max. 2 g)
		IM Reconstitute with lidocaine (lignocaine) 1% 2.3 mL to give a concentration of 350 mg/mL			IM Child See Guidelines for max. mL for IM injection, p. 67 Adult Inject deep into gluteal muscle. No more than 1 g in each site
Offer CMI: May cause rash, diarrhoea, nausea and pain at injection site					
Note: Rapid IV administration may result in seizures. Interacts with warfarin. ↓ dose in renal impairment					
Contraindication: Severe hypersensitivity to penicillins, carbapenems and cephalosporins. Do not use in neonates. Incompatible with calcium containing IV fluids eg Hartmann's. Do not mix with aminoglycosides					
Management of associated emergency: Consult MO/NP. See Anaphylaxis, p. 82					9,10

S ₄	Benzylpenicillin			Extended authority ATSIHP/IHW/IPAP	
ATSIHP, IHW, IPAP, RIPRN and RN must consult MO/NP					
Form	Strength	Route		Dose	Duration
Injection	600 mg 1.2 g	IV Reconstitute with water for injections: 600 mg vial with 5 mL 1.2 g vial with 10 mL THEN dilute in 100 mL sodium chloride 0.9%		Adult 2.4 g	stat
		IM Reconstitute 600 mg vial with 1.6 mL water for injections OR 1.2 g vial with 3.2 mL to give a concentration of 300 mg/mL			IV Infuse over at least 30 minutes
					IM Inject deep into large muscle. No more than 1 g in each site
Offer CMI: May cause diarrhoea, nausea and pain at the injection site					
Note: Rapid IV injection of large doses may cause seizures. Max. daily dose of 6 g in severe renal impairment					
Contraindication: Severe or immediate allergic reaction to a penicillin. Be aware of cross-reactivity between penicillins, cephalosporins and carbapenems					
Management of associated emergency: Consult MO/NP. See Anaphylaxis, p. 82					11

S4	Aciclovir			Prescribing guide
RIPRN and RN only. Must be ordered by an MO/NP				
Form	Strength	Route	Dose	Duration
Injection	250 mg 500 mg	IV/Intraosseous Reconstitute with water for injections: 250 mg with 10 mL 500 mg with 20 mL to give a concentration of 25 mg/mL THEN Dilute dose with sodium chloride 0.9% (max. concentration 5 mg/mL ie 250 mg to at least 50 mL or 500 mg to at least 100 mL) Shake to mix thoroughly	Neonate to < 12 years 20 mg/kg (max. 1000 mg) Note: dosing interval varies by age - seek specialist advice 12–16 years 10 mg/kg (max. 1000 mg) Adult 10 mg/kg	stat Infuse over at least 1 hour
		Offer CMI: May cause nausea, vomiting, diarrhoea, injection site reactions, hallucinations (high dose), headache or encephalopathy Note: Monitor injection site closely, extravasation can cause severe inflammation + necrosis. Stop the injection if redness/pain. Use in caution if neurological abnormalities. Adjust dose if renal impairment Management of associated emergency: Consult MO/NP. See Anaphylaxis, p. 82		

5. Follow up

- Chemoprophylaxis will be required for staff/close contacts of a patient with either meningococcal or Hib meningitis. Unvaccinated contacts of Hib meningitis < 5 years should be immunised as soon as possible. Public Health Unit will advise
- Refer for audiology assessment 6–8 weeks after discharge if bacterial meningitis¹³

6. Referral/consultation

- ① For all suspected or confirmed cases of meningitis or meningococcal disease notify the Public Health Unit within 6 hours

Choking (foreign body airway obstruction) - adult/child

Background

- Abdominal thrusts (Heimlich maneuver) are not recommended¹
- Consider foreign body aspiration in any infant/toddler with acute onset respiratory distress²

1. May present with^{1,2}

- Coughing
- Clutching the neck
- Extreme anxiety, agitation, gasping sounds
- Loss of voice, hoarseness, stridor
- Cyanosis, collapse

2. Immediate management¹⁻³

- Assess for effective cough

Effective cough (mild airway obstruction)

- Give reassurance
- Encourage coughing until foreign body is expelled
- Allow to position themselves
- Do not do back blows or chest thrusts while there is an effective cough
- Continue to check until recovery or deterioration

Ineffective cough and conscious (severe airway obstruction)

- Call for help
- **Do up to 5 sharp back blows:**
 - use the heel of your hand in the middle of the back between the shoulder blades
 - if infant - place in a head downwards position ie across your lap
- **If back blows unsuccessful, do up to 5 chest thrusts** - like chest compressions for CPR but sharper and delivered at a slower rate:
 - **infant** - place face up, back across your thigh
 - **child/adult** - sitting or standing position. **Support the patient's back when doing thrusts:**⁴
 - put your other hand on the patient's back OR on the back of the chair (if patient sitting) **OR**
 - get someone to stand behind patient to support the back **OR**
 - stand patient against a firm surface/wall **OR**
 - lie patient down

After each back blow or chest thrust, check to see if obstruction relieved

Aim is to relieve the obstruction rather than give all 5 blows/thrusts

- **If obstruction still not relieved and patient remains responsive:**
 - continue alternating 5 back blows with 5 chest thrusts

Unconscious or becomes unresponsive¹

- Call for help
- If solid material is visible in the mouth - remove
- Start CPR. See [BLS, p. 46](#)
- Urgently contact MO/NP

Foreign Body Airway Obstruction (Choking)

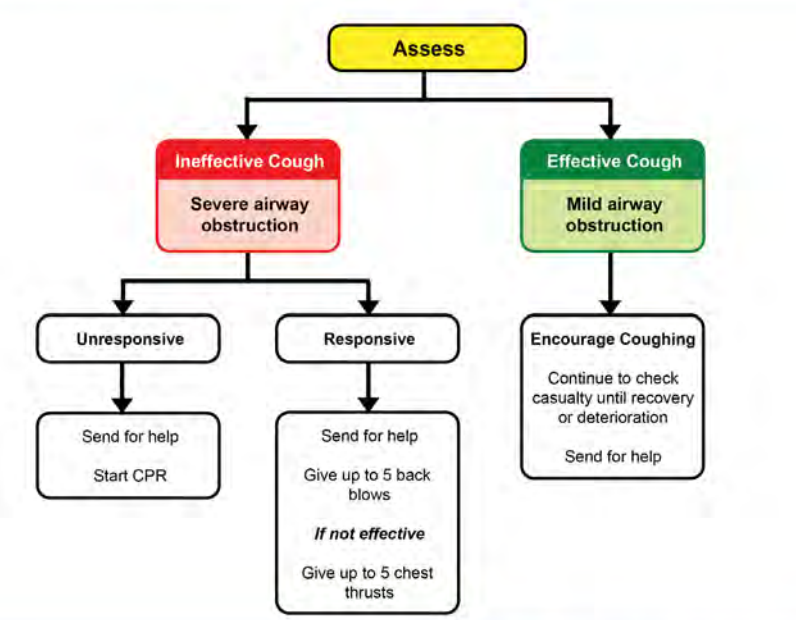

January 2016

3. Clinical assessment¹

- Get rapid history as able:
 - circumstances leading to choking eg eating, drinking, other
- Do vital signs
- Inspect chest for expansion, drawing in of spaces between ribs and clavicles
- Listen to the chest for air entry and added sounds (crackles or wheeze)

4. Management^{1,3}

- In cases of near (severe) choking or unseen positional foreign object:
 - consult MO/NP urgently
 - give O₂ to maintain SpO₂ ≥ 94%
 - prepare for evacuation
 - chest x-ray if indicated - on MO/NP orders
 - monitor vital signs
- If the choking episode is minor and the foreign body has been dislodged and removed:
 - if asymptomatic and chest findings normal, the patient can go home after a period of

- observation
 - if any concerns, contact MO/NP
- If choking as a result of a button battery, see [Button battery, p. 80](#)

5. Follow up

- If discharged, advise to be reviewed the next day:
 - consult MO/NP if the patient has any symptoms eg ↑ HR, ↑ T or any chest finding

6. Referral/consultation

- Consult MO/NP on all occasions of severe choking

Button battery ingestion/insertion - adult/child

Recommend^{1,2}

- A suspected or proven battery ingestion is a **time critical emergency - urgent x-ray needed**
- Suspect button battery ingestion in all children < 5 years of age with non-specific symptoms
- Promote button battery awareness eg <https://kidsafeqld.com.au/button-batteries/>

Background^{1,2}

- Button (disc) batteries cause burns resulting in life-threatening injuries
- **Failure to remove from the oesophagus within 2 hours can lead to perforation of the oesophagus, fistula (eg oesophageal-aortal/tracheal) and catastrophic haemorrhage**
- Oral honey may slow the development of a chemical burn for a swallowed button battery³

1. May present with^{1,2,4}

- Battery missing
- Seen to have been playing with battery
- Self reported by child (older)
- Gagging, gulp, cough or choking episode:
 - may be overheard when child swallows battery rather than directly observed
- Child may deny ingestion
- Very non-specific symptoms:
 - unexplained partial food refusal - may still take soft food/fluids
 - drooling or regurgitation
 - croup like cough
 - chest pain
 - upper GI bleeding (melaena/black stools; haematemesis - may mimic epistaxis):
 - may be small bleed initially, then catastrophic bleed
 - fever/vomiting/signs of infection without a clear focus
 - pain/grunting
- Bloody discharge from ear, nose, vagina, rectum - may have inserted battery

2. Immediate management

- If inhaled, see [Choking, p. 78](#)
- If haematemesis or melaena:
 - insert IVC x 2
 - get rapid history
 - urgently consult MO/NP
- Do vital signs

If ingestion (swallowed) suspected

- Contact the Poisons Information Centre (PIC) ☎ 13 11 26 (24 hours) urgently for advice
- Urgently contact MO/NP:
 - **urgent ‘neck to bottom’ x-ray required - even if asymptomatic¹**
 - if no x-ray facilities, will need urgent evacuation for x-ray
- If the x-ray shows battery is located in the hypopharynx (bottom of throat) or oesophagus:⁵
 - URGENT evacuation for removal via endoscopy required
- Give **oral honey** if ingestion suspected < 12 hours and:^{3,6}
 - child ≥ 12 months old
 - able to swallow
 - give 10 mL (2 teaspoons) every 10 minutes, up to 6 doses (or as guided by MO/NP)
- Keep nil by mouth otherwise
- If the battery is in the stomach or beyond:²
 - management will depend on factors such as age of child, symptoms, size of battery, time of suspected ingestion
 - MO/NP will advise
- Monitor vital signs

3. Clinical assessment

- Ask about - if known:
 - timing of ingestion
 - size of battery (if ≥ 2 cm, more likely to lodge in oesophagus)
 - was ingestion witnessed
 - what treatment (if any) has been tried at home
 - colour of stools, any blood in vomit, or any other signs/symptoms

4. Management

- Continue management of suspected swallowed battery in collaboration with MO/NP
- **If insertion suspected** eg into vagina, ear, rectum, nose:
 - consult MO/NP regarding urgent removal
 - x-ray may be required if unexplained nasal/ear/vaginal discharge and unable to visualise cause¹

5. Follow up

- As advised by MO/NP. **Note:** even after removal of a button battery, ongoing damage can occur⁷

6. Referral/consultation

- Always consult MO/NP

HMP Anaphylaxis - adult/child

Recommend¹

- Adrenaline (epinephrine) is first line treatment. Give without delay
- Anaphylaxis is potentially life-threatening and must be treated as a medical emergency
- Check for medic alert jewellery and accessories in emergency situations.² May look like normal jewellery or other accessory eg key ring, USB stick, shoe tag, anklet, watch or tattoo
- Fluid resuscitation is important if severe anaphylaxis with hypotension

Background

- See *ASCIA Guidelines - acute management of anaphylaxis* <https://allergy.org.au/hp/papers/acute-management-of-anaphylaxis-guidelines/>

1. May present with¹

- **ANY ONE of the following** (onset can range from minutes to hours after exposure to a substance):
 - difficult/noisy breathing
 - swelling of tongue
 - swelling/tightness in throat
 - difficulty talking ± hoarse voice
 - wheeze or persistent cough - usually sudden
 - persistent dizziness or collapse
 - pale and floppy (young children)
 - abdominal pain, vomiting - for insect sting or injected drug (medication) allergy
- **CONSIDER anaphylaxis in ANY acute onset:**
 - illness with typical skin features - itchy rash or red/flushing ± angio-oedema (swelling) **PLUS** involvement of respiratory ± cardiovascular ± persistent severe GI symptoms
 - **OR** hypotension or bronchospasm or upper airway obstruction where anaphylaxis is considered possible, even if typical skin features are not present

2. Immediate management¹ also see flowchart inside back cover

- **Remove allergen** if still present - **do not delay adrenaline (epinephrine) to do this:**
 - stop infusion of medicine/blood product
 - flick out insect stings; freeze tick with liquid nitrogen or ether containing spray
- **Call for help**
- **Lay patient flat. Do NOT allow to stand or walk** - can result in fatal hypotension
 - if breathing difficult allow to sit - with legs outstretched in front (not in chair):
 - lay flat again if ↓↓ BP or ↓↓ LOC or confusion
 - do not hold infants upright
 - if pregnant, put in left lateral position
- **Give IM adrenaline (epinephrine) into OUTER MID-THIGH WITHOUT DELAY**
 - repeat adrenaline (epinephrine) every 5 minutes as needed
 - if known **asthmatic with allergy** give adrenaline (epinephrine) **first**, then asthma reliever if **sudden breathing difficulty** (wheeze, persistent cough or hoarse voice) - even if no skin symptoms
- **Urgently consult MO/NP**

S ₃	Adrenaline (epinephrine)			Extended authority ATSHP/IHW		
ATSHP and IHW may proceed with up to 2 doses then must consult MO/NP						
MID, RIPRN and RN may proceed						
Form	Strength	Route	Dose		Duration	
Injection	1:1,000 1 mg/mL	IM Use 1 mL syringe with 22–25 G needle, 25 mm length or if very large adult, 38 mm length do NOT use insulin syringe	Adult and Child > 12 years 0.5 mg		stat Deep injection into outer mid-thigh Repeat every 5 minutes as required	
			Child ≤ 12 years 0.01 mg/kg (max. 0.5 mg)			
			Doses on approx. age/weight			
			Age (years)	Weight (kg)		Volume 1:1,000
			< 1	< 7.5		0.1 mL
			1–2	10		0.15 mL
			2–3	15		0.15 mL
			4–6	20		0.2 mL
			7–10	30		0.3 mL
10–12	40	0.4 mL				
> 12–adult	> 50	0.5 mL				
OR if using autoinjector eg EpiPen®, Anapen®						
Auto injector	0.15 mg	IM	7.5–20 kg (approx. 1–5 years) 0.15 mg			
	0.3 mg		> 20 kg (approx. > 5 years) 0.3 mg			
	0.5 mg		> 50 kg (approx. > 12 years) 0.3 mg OR 0.5 mg			
Offer CMI: May cause restlessness, anxiety or headache and palpitations in conscious patients						
Note: Instructions for autoinjector on device labels						
Management of associated emergency: Consult MO/NP						

1

When skills and equipment are available¹

- **Do NOT allow patient to walk or stand, even if they appear to have recovered**
- Cardiac monitor, ECG
- Monitor:
 - vital signs
 - for altered LOC and confusion. See [GCS/AVPU, p. 562](#)
- O₂ 6–8 L/minute if:
 - respiratory distress, ↓ LOC, or needs repeat doses of adrenaline (epinephrine)
 - consider O₂ if asthmatic, or chronic respiratory/cardiovascular disease
- Airway support if needed:
 - jaw thrust, oro/nasopharyngeal airway or bag-valve-mask with high flow O₂ will save most patients, even with airway swelling¹
- Insert IVC if adult (14–16 G) or hypotensive child

- If hypotensive:
 - IV sodium chloride 0.9% 20 mL/kg rapidly
 - + insert another IVC

If inadequate response to 2–3 adrenaline (epinephrine) doses OR deterioration

- MO/NP may consider:
 - **adrenaline (epinephrine) infusion** on advice of emergency medicine/critical care specialist
- If adrenaline (epinephrine) infusion NOT available or NOT effective **MO/NP may order for:**
 - **upper airway obstruction:**
 - nebulised adrenaline (epinephrine) 5 mL (5 ampoules of 1:1,000)
 - **persistent hypotension/shock:**
 - sodium chloride 0.9% - max. 50 mL/kg in the first 30 minutes
 - IV glucagon
 - **persistent wheeze:**
 - salbutamol 8–12 puffs (MDI) using a spacer OR 5 mg (NEB) as per [Asthma, p. 95](#)
 - oral prednisolone 1 mg/kg (max. 50 mg) as per [Asthma, p. 95](#) OR
 - IV hydrocortisone 5 mg/kg (max. 200 mg)
- **If airway not able to be maintained and SpO₂ falling consider** (if skills/equipment):
 - intubation - avoid prolonged attempts
 - cricothyrotomy
- **If cardiac arrest:**
 - see [ALS, p. 48](#)
 - do prolonged CPR
 - PLUS aggressive fluid resuscitation AND IV adrenaline (epinephrine) bolus

3. Clinical assessment[†]

- Get rapid history - from patient, relatives or friends:
 - food, medicine, sting/bite, herbal medicines, other exposures in the previous 6–8 hours
 - known allergies and reaction
 - any previous episodes, treatments used and effect
 - current medications, use of an autoinjector eg EpiPen®
- Do physical examination:
 - check affected body systems - skin changes, face, throat, breathing, HR, neurological state
- Monitor response to treatment - using simple palpable systolic BP:
 - palpate radial or brachial pulse. Note pressure at which this disappears
 - may be more difficult in children
 - **note:** infants can stay pale after 2–3 doses of adrenaline (epinephrine), which can resolve without further doses. Use BP to guide response
- Monitor for signs of over treatment:
 - hypertension or pulmonary oedema

S ₄	Hydrocortisone			Extended authority ATSIHP/IHW/IPAP
ATSIHP, IHW, IPAP, MID, RIPRN and RN must consult MO/NP				
Form	Strength	Route	Dose	Duration
Injection	100 mg	IV Reconstitute with 2 mL water for injections	5 mg/kg (max. 200 mg)	stat - inject over 30 seconds–5 minutes
Management of associated emergency: Consult MO/NP				1,3,4

S3	Adrenaline (epinephrine)			Prescribing guide
MID, RIPRN and RN only. Must be ordered by an MO/NP				
Form	Strength	Route	Dose	Duration
Injection	1:1,000 1 mg/mL	IV INFUSION only in separate IV line	1:1,000 (1 mL) Dilute in 1,000 mL sodium chloride 0.9%	Start infusion at ~ 5 mL/kg/hour (~0.1 microg/kg/minute) using a pump Titrate rate up or down according to response and side effects If pump not available, start at ~ 2 drops/second using standard giving set
Monitor continuously: ECG, SpO ₂ + frequent BP to maximise benefit and minimise risk of adrenaline (epinephrine) toxicity eg nausea, shaky, vomiting, tachycardia, but with normal BP DO NOT GIVE IV BOLUS of adrenaline (epinephrine) unless in cardiac arrest situation. Do not stop suddenly. Extravasation can cause ischaemia and necrosis				
Management of associated emergency: Consult MO/NP				1,5

4. Management¹

When stable

- Monitor closely for at least 4 hours after last dose of adrenaline (epinephrine):
 - relapse/protracted ± biphasic (two phase) reactions may occur
- BP, RR, HR, LOC - 15 minutely for 2 hours then hourly
- Evacuation/hospitalisation may be required if:
 - severe reaction eg required repeated doses of adrenaline (epinephrine) or IV resuscitation OR
 - severe/protracted anaphylaxis OR
 - has other concomitant illness eg asthma, arrhythmia OR
 - lives alone or remote from medical care OR
 - presents for medical care late in evening
- If not evacuated, continue to manage as per MO/NP instructions
- Document allergy in medical record

Patient advice prior to discharge

- Avoid being re-exposed to the allergic trigger
- If there is a risk of re-exposure (eg stings, food) **OR unknown cause** provide:
 - an autoinjector of adrenaline (epinephrine) on discharge, or script for an autoinjector
 - education of how and when to use the autoinjector
- Give an *ASCIA action plan for anaphylaxis* <https://www.allergy.org.au/hp/anaphylaxis/ascia-action-plan-for-anaphylaxis>
- Refer to Allergy and Anaphylaxis Australia <https://allergyfacts.org.au/allergy-anaphylaxis> for support
- Discuss medical alert jewellery

5. Follow up

- If not evacuated advise to be reviewed the next day, or earlier if concerned
- Advise to see MO/NP at next clinic

6. Referral/consultation

- Ensure referred to clinical immunology/allergy specialist¹
- Report adverse reaction to immunisation or medicine $\text{\textcircled{D}}$:
 - immunisation - in Qld use AEFI form <https://www.health.qld.gov.au/clinical-practice/guidelines-procedures/diseases-infection/immunisation/service-providers/adverse-event>. If outside of Qld use local reporting systems
 - medicine - report directly to the TGA <https://www.tga.gov.au/form/blue-card-adverse-reaction-reporting-form>

HMP Fitting - adult/child Convulsions, seizures

Recommend

- **Status epilepticus** is continuous seizure activity or repeated seizures without full recovery to normal LOC between episodes - **neurological emergency, aim to stop seizure urgently**^{1,2}

Background

- Most fits are brief + end within 1–3 minutes without needing midazolam²
- Febrile convulsions occur with rapid \uparrow T in early acute illness in child aged 6 months–6 years¹
- If child, also see *Status epilepticus; Febrile convulsions - emergency management in children* <https://www.childrens.health.qld.gov.au/qpec-statewide-guidelines/>

1. May present with

- Fitting eg:^{1,3}
 - sudden body stiffening, will fall if standing
 - jerking movements, head arching back
 - shallow breathing or may stop temporarily
 - dribbling, blood stained if tongue bitten
 - \pm fever in child
- Pregnant + fitting, see [Preeclampsia, p. 386](#) for magnesium sulphate infusion + ongoing management
- Post seizure - drowsy, confused, incontinent, agitated, noisy breathing if partial airway obstruction³

2. Immediate management

- **Fitting:**^{2,3}
 - protect patient's head + avoid restraining unless essential to avoid injury
 - lay down + turn on the side when practical
 - note the time
 - maintain airway - do not force mouth open or attempt to insert object
 - insert IVC if possible
 - do BGL - if < 4 **adult**, < 3 **child** - treat [Hypoglycaemia, p. 91](#) concurrently
 - contact MO/NP urgently
- **Status epilepticus:**^{1,2}
 - **if fitting > 5 minutes** or repeated seizures without full recovery to normal LOC
 - give midazolam +
 - repeat if seizure continues after 5 minutes - as per MO/NP

- MO/NP will seek urgent advice + may order 2nd agent eg:
 - levetiracetam, phenobarbitone or phenytoin¹
- Do:
 - continuous cardiac monitoring - assess for arrhythmias
 - [GCS, p. 562](#) + vital signs. Check for ↓↓BP
 - check for complications eg airway, aspiration, hyperthermia, IV site for extravasation
 - monitor closely until evacuated
- **Post seizure:**
 - insert oropharyngeal airway if needed
 - place in recovery position³
 - give O₂ to maintain SpO₂ ≥ 94%
 - cardiac monitoring²
 - take bloods/i-STAT - VBG, FBC, UE²
 - reassure patient/family/carers - fitting can be extremely distressing¹
- Do vital signs + [GCS, p. 562](#)

Look for causes + manage concurrently^{1,2}

- Screen for [Sepsis, p. 64](#)
- If [Alcohol withdrawal, p. 356](#) cannot be excluded give IV thiamine
- Suspected poisoning or drug overdose - see [Toxicology assessment, p. 212](#)
- Epilepsy - adherence with therapy, recent sleep deprivation²

S4	Midazolam			Extended authority ATSIHP/IHW/RIPRN
ATSIHP, IHW and RN must consult MO/NP				
RIPRN may proceed				
Form	Strength	Route	Dose	Duration
Injection	5 mg/5 mL 5 mg/1 mL	IV/IM (ATSIHP + IHW may NOT give IV)	Adult 5–10 mg Child 0.15 mg/kg (max. 10 mg)	stat If IV, give as push
		Buccal	Adult 5–10 mg Child	Consider repeat dose if no effect after 5–10 minutes on MO/NP order
	Intranasal	0.3 mg/kg (max. 10 mg)		
Administration advice: Buccal: slowly drip into mouth between gums and cheek using a syringe or squeeze directly from the <i>plastic ampoule</i> . Intranasal: use mucosal atomisation device (MAD) or 1–3 drops (<i>plastic ampoule</i>), 1 at a time into alternate nostrils until full dose is given (over 15 seconds)				
Note: Monitor for sedation and respiratory depression				
Management of associated emergency: Consult MO/NP. See Anaphylaxis, p. 82				2,4

3. Clinical assessment

- **Ask about details leading up to fitting**, including:¹
 - prior events
 - changes in behaviour
 - signs/symptoms of illness, fever

- **Get details of the fitting**, including:¹
 - how it started
 - any movements of eyes + limbs, symmetry of movements
 - focal movements eg rubbing of hands, lip smacking
 - estimated duration + appearance/behaviour after
 - pre-hospital treatment
- **Get past history:**^{1,2}
 - previous fits or family history + previous management
 - medical/surgical eg intracranial infection, hypoglycaemia/electrolyte disturbance, neurological damage/surgery eg placement of ventriculoperitoneal (VP) shunt
- **Do physical examination**, including:⁵
 - if child + fever - look for source eg URTI, pneumonia, AOM, UTI
 - assess neurological status + return to normal level of alertness + activity¹
 - ECG²
 - check for injuries²
 - pregnancy test if female of reproductive age. If +ve consider [Eclampsia, p. 386](#)

4. Management

- Ongoing management as per cause in collaboration with MO/NP
- **If brief seizure < 5 minutes:**^{1,2}
 - observe/monitor for ongoing seizures
 - further investigations as per MO/NP
 - consider discharge if:¹
 - cause of seizure is certain
 - no further seizures for several hours + patient is alert/responding normally
 - observations, including GCS, pupil reaction, BP, HR - within normal ranges
 - family/caregivers are able to safely manage the patient at home
- **If child with febrile convulsion:**⁵
 - MO/NP will advise, based on source of fever. **Note:** if any doubt check clinical features against *Febrile convulsions - emergency management in children* <https://www.childrens.health.qld.gov.au/qpec-statewide-guidelines/>
 - give ibuprofen ± paracetamol if uncomfortable. See [Acute pain, p. 32](#)
 - consider discharge if:
 - returned to normal age appropriate baseline neurology
 - infection source identified that can be managed in community
 - give *Febrile convulsions* factsheet eg <https://www.childrens.health.qld.gov.au/fact-sheet-febrile-convulsions/>
- Advise family/carers about:^{1,5}
 - first aid/how to manage subsequent seizure eg *First aid management of a seizure* <https://resus.org.au/guidelines/>
 - return promptly if deterioration/another seizure

5. Follow up

- If discharged, advise review the next day or sooner if concerned/recurrent seizure - contact MO/NP urgently. Also see MO/NP at next clinic + advise not to drive until cleared by a specialist

6. Referral/consultation

- MO/NP will advise if specialist referral required

Diabetic ketoacidosis (DKA) - adult/child

Hyperosmolar hyperglycaemic state (HHS)

Recommend

- Can be rapidly fatal. Avoid delays to treatment - IV fluids, potassium replacement + IV insulin^{1,2}
- Be aware - excessive thirst + frequent urination can be a sign of undiagnosed diabetes

Background

- DKA - BGL > 11 + acidosis, sudden onset^{1,3}
- HHS - BGL > 33.3 + profound dehydration without ketosis - gradual onset, commonly caused by acute illness¹
- If child, also see *DKA and HHS - emergency management in children* <https://www.childrens.health.qld.gov.au/qpec-statewide-guidelines/>
- If adult, also see *Management of diabetic ketoacidosis in adults (age ≥ 16 years and over)* <https://clinicalexcellence.qld.gov.au/resources/diabetes-resources/diabetic-ketoacidosis>

1. May present with⁴

- \uparrow BGL
- Rapid breathing (Kussmaul breathing)
- Excessive thirst, dehydration
- Abdominal pain \pm vomiting
- Fruity sweet smelling breath (acetone - similar to paint thinner or nail polish remover)
- Confusion, \downarrow LOC or unresponsive
- **Note:** DKA occurs mainly in patients with type 1 diabetes. It is also seen in patients with type 2 diabetes, particularly if taking sodium-glucose co-transporter 2 (SGLT2) inhibitors, when DKA may occur without hyperglycaemia⁵

2. Immediate management^{2,3}

- **DRSABCD**
- Rapidly assess + manage concurrently
- Do vital signs
- Insert IVC x 2 into large veins
- Take bloods/i-STAT - FBC, UE, LFT, glucose, VBG
- Start IV fluids - sodium chloride 0.9%
 - **adult** 1000 mL/hour, repeat if systolic BP < 100
 - **child** only give on MO/NP order
- Finger prick/blood ketones if available³
- **Contact MO/NP urgently**
- Look for signs of acute illness^{4,3} eg *Sepsis, p. 64, ACS, p. 107, Stroke, p. 130*
- Start fluid balance
- Continuous cardiac monitoring
- Do neurological observations - excessive fluids can cause cerebral oedema eg headache, \downarrow LOC, agitation/aggression^{2,3}
- If patient is using a continuous subcut insulin pump, disconnect it³

3. Clinical assessment

- Get history, including:¹
 - polyuria + excessive thirst, **note:** may be absent in young child³
 - if toilet trained child - any new bed wetting or ‘accidents’³
 - recent weight loss, ↑ appetite^{2,3}
 - vomiting, abdominal pain, non-specific symptoms + malaise³
- If known diabetic, ask about:¹
 - unstable glycaemic control or review continuous glucose monitoring (CGM) device data if available
 - antihyperglycaemics, insulin - total daily dose, adherence to regimen⁵
 - past DKA
 - initiation of new medicines including over-the-counter
- Do physical examination, including:^{2,3}
 - look for signs of infection eg appendicitis, ileus + pancreatitis
 - weight
 - Hydration assessment - adult, p. 200 or child, p. 535
 - ECG
 - urinalysis for ketones - if blood ketones not available
 - MSU for MCS + pregnancy test if female of reproductive age

4. Management

- MO/NP will arrange urgent evacuation + may order:^{2,3}
 - potassium replacement + IV short acting insulin infusion eg Actrapid®, see **Management guide**
 - give patient’s usual subcut long acting insulin (if already on it)
- If ↑ BGL + ketones but not acutely unwell, closely monitor + aggressively manage to prevent DKA²

Management guide - use local protocol if available	
≥ 16 years ²	<ul style="list-style-type: none"> • Aggressive IV sodium chloride 0.9% ± potassium • Start IV insulin infusion as per MO/NP - max. starting dose 10 units/hour: <ul style="list-style-type: none"> – ongoing rate titrated to BGL, aim to maintain BGL 9–14 • When BGL < 14 - start glucose 10% at 100 mL/hour • If BGL < 9 - ↑ rate of glucose as per MO/NP
< 16 years ³ Note: do not use adult protocol	<ul style="list-style-type: none"> • Start IV insulin infusion as per MO/NP (1 hour after starting IV fluids) • Rate as per MO/NP - ideal continuous dose 0.1 unit/kg/hour via syringe pump • If BGL falls to ≤ 15 - MO/NP may advise IV sodium chloride 0.9% with glucose 5% + potassium 40 mmol. See fluid recipe for how to prepare https://www.childrens.health.qld.gov.au/qpec-paediatric-resuscitation-tools/#tab-foa925fdb661980a62 • Do not reduce insulin infusion rate unless advised
Monitor closely until evacuated	<ul style="list-style-type: none"> • Continuous cardiac monitoring - assess for T wave changes³ • Do hourly BGL + <ul style="list-style-type: none"> • Vital signs + neurological observations/signs of cerebral oedema • Strict fluid balance • UE + VBG - 2nd hourly or as per MO/NP
MO/NP may also advise	<ul style="list-style-type: none"> • Nil by mouth/ice to suck • Insert nasogastric tube, IDC • If suspected infection - antibiotics, blood cultures, throat swab²

5. Follow up

- As per MO/NP

6. Referral/consultation

- As above

HMP Hypoglycaemia - adult/child

Recommend

- Hypoglycaemia is a medical emergency. If left untreated it can cause convulsions, irreversible brain damage + death¹

Background

- Most common cause in children is ketotic hypoglycaemia (KH), a physiological condition that is a variant of normal + expected in a fasting state. Most outgrow KH by mid - late primary school¹
- For known diabetics, hypoglycaemia may be secondary to insulin use
- If child, also see *Unexplained hypoglycaemia - emergency management in children* <https://www.childrens.health.qld.gov.au/qpec-statewide-guidelines/>

1. May present with^{2,3}

- BGL < 4 adult, < 3 child
- Sweating, pale skin, shaking, palpitations, feeling anxious
- Hunger, difficulty concentrating, confusion/inappropriate behaviour
- Loss of consciousness, seizures
- Child - drowsy, listless + lethargic¹

2. Immediate management

- Do BGL - rapidly assess + manage concurrently - avoid delays
- If child + BGL < 3 on glucometer:¹
 - **confirm BGL** on i-STAT + finger prick/blood ketones if available

ALERT if hazardous alcohol use or severely malnourished^{3,4}

Give thiamine before glucose in any form

Glucose may deplete thiamine stores causing Wernicke encephalopathy

If severe - unconscious/fitting OR child with confirmed BGL ≤ 2.6 ^{1,3}

- Insert IVC into antecubital vein
- Give IV bolus glucose 10% **OR** IM/subcut glucagon if IV will cause delay
- Contact MO/NP urgently
- **Note:** most fitting is brief - if lasting > 5 minutes, give midazolam as per [Fitting, p. 86](#)
- Monitor closely - patients given IV glucose respond within minutes
- Do vital signs + neurological observations ie:⁵
 - GCS, p. 562
 - pupil size + reaction to light
 - motor response in limbs
 - fontanelle in infant
- Repeat BGL 10–15 minutes, if < 4 repeat glucose as per MO/NP

- If patient is using a continuous subcut insulin pump, disconnect it¹
- If confusion/loss of consciousness - recovery may take hours, even if normal BGL³
- **If child** - MO/NP may order:¹
 - IV infusion of glucose 10% + sodium chloride 0.9% at maintenance rate
 - **to prepare** use 1 L bag of glucose 5% with sodium chloride 0.9%, withdraw 100 mL + discard. Inject 100 mL of glucose 50% into the bag + mix well
 - urine metabolic screen - get the first urine passed after BGL \leq 2.6, regardless of age + time since episode, use urine bag if needed
- Ongoing management as per MO/NP who may advise:
 - urgent evacuation
 - antiemetic + IV fluids if dehydrated¹
 - when able, oral fluids + carbohydrate snack

If conscious/cooperative^{2,3}

- Give oral glucose:
 - **adult** - 15 g tube of glucose gel, or if BGL $<$ 3 give 20 g
 - **child** confirmed BGL $>$ 2.6 - give sugary drink/fruit juice or flavoured ice block - do not give hyalate ice block
- If glucose gel not available, give alternative eg:²
 - 5–20 jelly beans, 20–25 Skittles®, 5–10 Mentos®
 - sugary drink/fruit juice 200 mL - DO NOT give diet/zero/sugar free
 - OGTT drink, or 3 teaspoons of honey/sugar
- Give a carbohydrate snack eg 1 slice of bread/glass of milk/piece of fruit/2–3 pieces of dried fruit/snack size tub of yoghurt - not diet/sugar free²
- Repeat BGL in 10–15 minutes. If $<$ 4 repeat glucose as per MO/NP³
- If patient is using a continuous subcut insulin pump, ask them to stop it¹
- Consult MO/NP in all cases

Unscheduled	Glucose			
ATSHP, IHW and IPAP must consult MO/NP				
RIPRN and RN may proceed for adult only. Must consult MO/NP for child				
Form	Strength	Route	Dose	Duration
Injection	10% in 500 mL	IV/ Intraosseous	Child and adolescent 2 mL/kg (max. 100 mL)	Infuse over 20 minutes until BGL $>$ 4
			Adult 150–200 mL	Infuse over 15 minutes
Management of associated emergency: Contact MO/NP. See Anaphylaxis, p. 82				4,3

S3	Glucagon			Extended authority ATSHP/IHW
ATSHP, IHW, RIPRN and RN may proceed				
Form	Strength	Route	Dose	Duration
Injection	1 mg	IM/Subcut	Adult and child $>$ 25 kg 1 mg	stat Further doses on MO/NP order
			Child \leq 25 kg 0.5 mg	
Offer CMI: May cause nausea, vomiting or allergic reaction				
Note: Reconstitute before use. Response should occur within 10 minutes				
Management of associated emergency: Consult MO/NP. See Anaphylaxis, p. 82				3

Unscheduled	Thiamine			
ATSIHP, IHW, IPAP, RIPRN and RN may proceed				
Form	Strength	Route	Dose	Duration
Injection	300 mg/3 mL	IV Dilute in 10–20 mL of sodium chloride 0.9% or IM undiluted	Adult 300 mg	stat Inject IV slowly over 10 minutes
Note: Give thiamine before administering glucose for hypoglycaemia. Giving glucose in thiamine deficiency may precipitate Wernicke encephalopathy				
Management of associated emergency: Contact MO/NP. See Anaphylaxis, p. 82				3

3. Clinical assessment

- **If known diabetic**, ask about:⁶
 - antihyperglycaemics, insulin - type, total daily dose, adherence³
 - recent alcohol³
 - unstable glycaemic control, past hypoglycaemic events or review continuous glucose monitoring (CGM) device data if available
 - do they have a diabetes management plan
- **Look for other causes**, ask about:³
 - severe vomiting, diarrhoea or fasting in last 3 days - most common cause in children:¹
 - if fasted - how long before becoming hypoglycaemic
 - stopping hyperglycaemia-inducing drugs eg glucocorticoids
 - drugs + alcohol misuse/withdrawal
 - vigorous ± prolonged exercise, exposure to heat
 - recent unexplained weight loss/gain
- **If child without clear cause**, ask about:¹
 - difficulty to wake in the morning
 - fasting overnight, if so how long
 - recent protein meal, fruit or honey
 - potential ingestion eg insulin, metformin, beta-blockers, quinine, chloroquine, salicylates + valproate
- **Get past history**, including:³
 - cognitive or kidney impairment
 - liver disease¹
 - coeliac disease, bariatric surgery eg gastric sleeve/bypass
 - hypopituitarism, adrenal cortical failure
- **Do physical examination**, including:¹
 - [Hydration assessment - adult, p. 200](#) or [child, p. 535](#)
 - weight
 - if child - urinalysis for ketones (if blood ketones not available)¹
 - pregnancy test if female of reproductive age
- Take bloods:
 - i-STAT - UE, LFT, VBG, glucose, lactate
 - + as per MO/NP

4. Management

- **Monitor closely until evacuated:**
 - BGL every 15 minutes until normal, then hourly or as per MO/NP^{1,3}
 - hourly - vital signs, neurological observations + IV site for signs of extravasation^{1,3}

If non-severe hypoglycaemia³

- Check BGL 15 minutely until normal, then 1–2 hourly for 4 hours
- If at high risk for thiamine deficiency will need ongoing thiamine - consult MO/NP
- Check diabetes management plan (if in place)
- Consult MO/NP prior to discharge
- Give advice on preventing/recognising hypoglycaemia events eg:³
 - have access to glucagon injection + be trained to give it
 - know diabetes first aid eg *First Aid management of a diabetic emergency* <https://resus.org.au/guidelines/>

5. Follow up

- Advise to be reviewed the next day or sooner if recurrent hypoglycaemia - contact MO/NP

6. Referral/consultation

- Offer referral to diabetes educator for management plans

HMP Acute asthma - adult/child

Recommend¹

- Beware of severe asthma in patient with no wheeze and unable to speak
- Resources <https://www.astmahandbook.org.au/>

1. May present with¹

- Breathlessness, speaking in short sentences
- Wheeze/cough
- ↑ WOB, ↓ SpO₂
- Symptoms continue despite using puffer
- Cyanosis, exhaustion, drowsy/collapsed, quiet chest, poor respiratory effort

2. Immediate management¹

- **Consider and treat Anaphylaxis, p. 82** if asthma like symptoms **AND**
 - features of anaphylaxis eg itchy rash, angio-oedema (swelling) **OR**
 - history of allergy **OR**
 - if suspected or cannot be excluded
- **If < 12 months of age** contact MO/NP:
 - do not treat as asthma. **Bronchiolitis, p. 503** or small floppy airways likely cause of wheeze

Step 1 - assess severity

Mild/Moderate	Severe	Life-threatening
<ul style="list-style-type: none"> • Can walk, speak whole sentences in 1 breath • Young child - can move around and speak in phrases • SpO₂ > 94% 	<p>ANY of:</p> <ul style="list-style-type: none"> • Unable to speak in sentences • Visibly breathless • Obvious respiratory distress • Use of accessory muscles: <ul style="list-style-type: none"> – neck or intercostal – tracheal tug or subcostal recession • SpO₂ 90–94% 	<p>ANY of:</p> <ul style="list-style-type: none"> • Drowsy, collapsed • Exhaustion • Cyanosis • Poor respiratory effort, soft/absent breath sounds • SpO₂ < 90%

Give salbutamol immediately

See **Step 2**
(next page)

- **If patient unresponsive, cannot inhale bronchodilators OR respiratory arrest imminent**
- Give IM adrenaline (epinephrine) 1:1,000
 - same doses as **Anaphylaxis, p. 82**
 - repeat every 3–5 minutes if needed

Step 2 - give salbutamol ± ipratropium

Mild/Moderate	Severe	Life-threatening
Salbutamol puffer with spacer	Salbutamol puffer + ipratropium puffer with spacer or NEB if unable use puffer	Continuous salbutamol NEB + ADD ipratropium to NEB
<p>Note: NEBs carry high risk of transmitting viral infections - use PPE Aerosol droplets can spread for several metres and stay airborne for > 30 minutes¹</p>		

Give O₂ if SpO₂ < 92% in adult or < 95% in child¹
Target: adult 93–95%, child ≥ 95%
 Do not over-oxygenate

If severe or life-threatening at any time

- Call for help
- **Urgently contact MO/NP**
- Urgent evacuation
- Be prepared for rapid deterioration ± cardiorespiratory arrest

Step 3
Within minutes, reassess severity using table below:

- general appearance
- LOC, speech
- listen to chest, look for use of accessory muscles
- vital signs

Mild/Moderate	Severe	Life-threatening
<p>ALL of:</p> <ul style="list-style-type: none"> • Alert, can walk • Can finish a sentence in 1 breath • For young child: can crawl, talk or vocalise • Respiratory distress not severe • Wheeze or normal lung sounds • RR: <ul style="list-style-type: none"> – adult < 25 – child - normal range* • HR: <ul style="list-style-type: none"> – adult < 110 – child - normal range* • SpO₂ > 94% 	<p>ANY of:</p> <ul style="list-style-type: none"> • Can only speak a few words in 1 breath • Lethargic • Unable to lie flat due to SOB • Sitting hunched forward • Use of accessory muscles: <ul style="list-style-type: none"> – chest sucks in when breathes in, or – neck or intercostal, or – tracheal tug or abdominal breathing (subcostal recession) • RR: <ul style="list-style-type: none"> – ≥ 6 years–adult ≥ 25 – < 6 years - tachypnoea* • HR: <ul style="list-style-type: none"> – adult ≥ 110 – child - tachycardia* • SpO₂ 90–94% 	<p>ANY of:</p> <ul style="list-style-type: none"> • Drowsy or unconscious • Collapsed or exhausted • Severe respiratory distress or poor respiratory effort • Cyanosis • Silent chest or ↓ air entry • Abnormally slow breathing /respiratory exhaustion • Soft/absent breath sounds • Arrhythmia or bradycardia - may occur just before arrest • SpO₂ < 90%
<p>*Child vital signs as per CEWT</p> <p>Reduced wheezing alone is an unreliable indicator of improvement. It may mean deterioration</p>		

▶ **Go to Step 4**

S ₃ MDI S ₄ NEB	Salbutamol		Extended authority ATSIHP/IHW/RIPRN	
RN may proceed with MDI. NEB - on MO/NP order (or standing order)				
ATSIHP and IHW may proceed with 1 dose then consult MO/NP				
RIPRN may proceed				
Form	Strength	Route	Dose	Duration
MDI (puffer)	100 microg/ puff	Inhalation Use spacer + <i>mask if young child</i>	Mild/moderate ≥ 6 years—adult 4–12 puffs 1–5 years 2–6 puffs Severe ≥ 6 years—adult 12 puffs 1–5 years 6 puffs	stat Mild/moderate Give every 20–30 minutes for 1st hour if needed Severe
Nebule	2.5 mg/ 2.5 mL 5 mg/ 2.5 mL	NEB *With air or O ₂ 6–8 L/ minute	Severe ≥ 6 years—adult 5 mg nebule 1–5 years 2.5 mg nebule Life-threatening ≥ 6 years—adult 2 x 5 mg nebules 1–5 years 2 x 2.5 mg nebules	Give at least every 20 minutes for 1st hour Give sooner if needed Life-threatening Give continuously Refill as needed
Offer CMI: May cause tremor, palpitations or headache				
Note: *Give NEB with air in adult unless O ₂ needed or life-threatening. Give with O ₂ in child. If spacer not anti-static, prime with 10 puffs of salbutamol. ¹ After each puff, take 4 breaths in and out of the spacer. Remove from mouth and shake prior to next puff				
Management of associated emergency: Observe for salbutamol toxicity eg tachycardia, tachypnoea. Consult MO/NP 1,2				

S ₄	Ipratropium		Extended authority ATSIHP/IHW/IPAP/RIPRN	
RN must consult MO/NP				
ATSIHP, IHW and IPAP may proceed with first dose then consult MO/NP				
RIPRN may proceed				
Form	Strength	Route	Dose	Duration
MDI (puffer)	21 microg/puff	Inhalation Use spacer + <i>mask if young child</i>	Severe ≥ 6 years—adult 8 puffs 1–5 years 4 puffs	stat Give every 20 minutes for 1st hour
Nebule	250 microg/mL 500 microg/mL	NEB With air or O ₂ 6–8 L/minute	Severe or life-threatening ≥ 6 years—adult 500 microg 1–5 years 250 microg	Further doses on MO/NP order
Offer CMI: May cause dry mouth, throat irritation, headache, taste disturbance or nausea. If using NEB, patient should close their eyes or wear eye protection. Avoid getting mist into eyes				
Management of associated emergency: Consult MO/NP. See Anaphylaxis, p. 82 1,3				

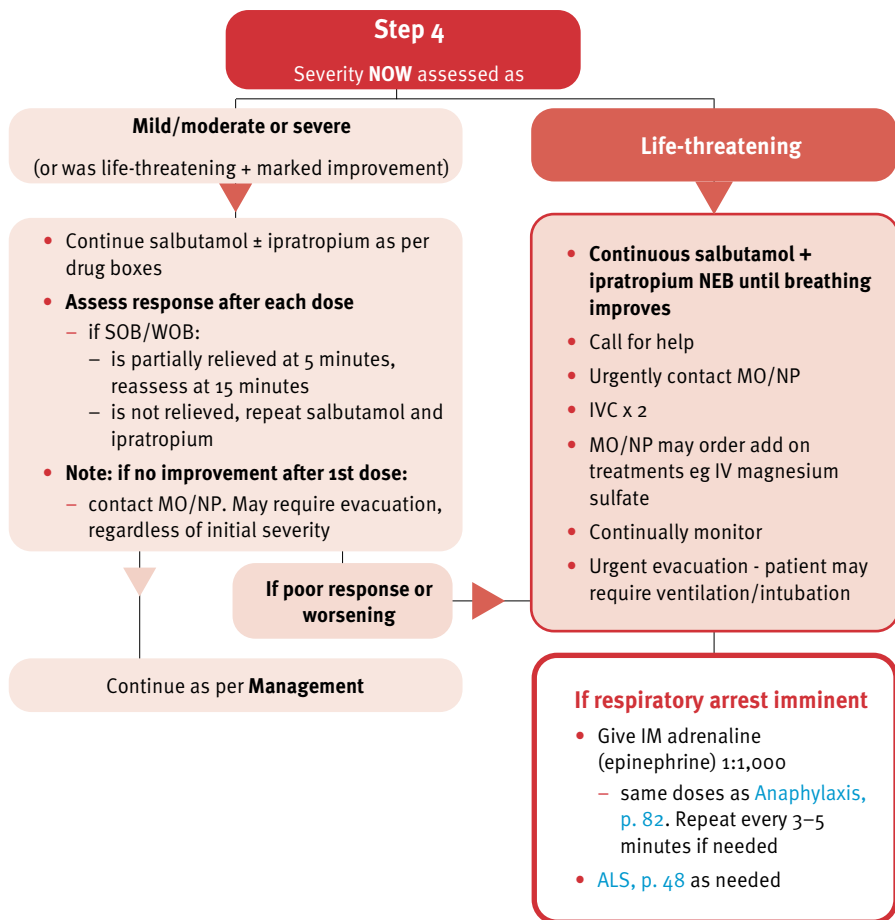

Unscheduled	Magnesium sulfate			Prescribing guide
RIPRN and RN only. Must be ordered by an MO/NP				
Use local protocols for administration of magnesium sulfate if available				
Form	Strength	Route	Dose	Duration
Injection	2.5 g/5 mL	IV	Adult 2.5 g	Infuse over 20 minutes
			Dilute in 100 mL sodium chloride 0.9%	
			Child ≥ 2 years 25–50 mg/kg (max. 2 g)	
			Dilute the 5 mL ampoule with at least 7.5 mL of sodium chloride 0.9% to make a concentration of 200 mg/mL or weaker	
Offer CMI: Relaxes bronchial smooth muscle. May cause nausea, vomiting or flushing				
Contraindication: Heart block, hypermagnesaemia				
Management of associated emergency: Hypermagnesaemia unlikely with single dose. Cease infusion. Contact MO/NP				

1,4,5

3. Clinical assessment¹

- Get rapid history:
 - reliever puffer taken for this episode - dose, number of doses, time of last dose
 - current asthma medicine(s)
 - if prescribed preventer puffer, are they using it correctly
 - what triggered this episode, if known eg allergy, hypersensitivity, medicine, URTI
 - heart or lung disease, COPD
 - smoker, exposure to second hand smoke
 - previous ICU/hospital admission(s) for asthma
- **Closely monitor:**
 - vital signs - **in particular** fatigue, LOC, RR, HR, SpO₂
 - in adults avoid SpO₂ > 95% as risk of ↑ CO₂ in blood
 - if COPD aim for SpO₂ 88–92%
 - do spirometry if available, patient able and staff trained

4. Management¹

- Continue to manage severe and life-threatening asthma, or mild asthma that is not responding, in collaboration with MO/NP

Within 1 hour start corticosteroids

- Give for all presentations, even mild
- Adult and child ≥ 6 years:
 - oral prednisolone **OR** IV hydrocortisone if oral route not possible
- Child 1–5 years - only on MO/NP order **AND** if severe wheezing

1 hour after 1st dose of salbutamol - reassess response to treatment

- Use assessment tool in **Step 3**

If still not improving

- If persisting respiratory distress **OR** ↑ WOB **OR** not able to lie flat without SOB:
 - **urgently contact MO/NP**
 - continue to give salbutamol every 20 minutes
 - MO/NP may consider add on treatments eg IV magnesium sulfate
 - evacuation/hospitalisation

- **MO/NP may consider evacuation/hospitalisation if:**¹
 - hypoxia at presentation
 - respiratory distress, ↑ WOB unresolved or unable to lie flat without SOB 1–2 hours after presentation
 - history of ICU admission for asthma, or hospitalised ≥ 2 in last year
 - frequent presentations for acute asthma
 - high recent use of salbutamol
 - patient cannot be monitored well at home
 - other risk factors eg poor asthma control, chronic lung disease, cardiovascular disease

If mild/moderate episode, no fever and SOB/WOB resolves¹

- Observe for at least 3–4 hours (or as per MO/NP) after breathing difficulty resolves:¹
 - if breathing difficulty persists OR returns, contact MO/NP
 - if no further breathing difficulty patient may return home
- Advise to continue usual asthma medicines, including:
 - salbutamol puffer 4 hourly as needed - supply remainder of MDI
 - preventer puffer (if prescribed)
- Check and coach inhaler technique - give spacer + care instructions (if does not have one)
- Check patient knows how to recognise asthma symptoms and what to do. Give discharge plan eg <https://www.asthmahandbook.org.au/acute-asthma/clinical/post-acute-care>

S ₄	Prednisolone			Extended authority
ATSIHP, IHW, IPAP and RN must consult MO/NP				
RIPRN may proceed for adult and child ≥ 6 only				
Form	Strength	Route	Dose	Duration
Tablet	1 mg, 5 mg, 25 mg	Oral	Adult 50 mg	stat Then repeat each morning for 5–10 days
Oral liquid	5 mg/mL		Child 6–11 years and child 1–5 years with severe wheeze 1 mg/kg (max. 50 mg)	stat Then repeat each morning on days 2 and 3 <i>A longer course may be needed for severe cases eg 5 days - consult MO/NP</i>
Offer CMI: May affect mood and sleep. Take with food to help reduce stomach upset				
Management of associated emergency: Consult MO/NP. See Anaphylaxis, p. 82 1,6				

S ₄	Hydrocortisone			Extended authority
ATSIHP, IHW, IPAP, RIPRN and RN must consult MO/NP				
Form	Strength	Route	Dose	Duration
Injection	100 mg	IV Reconstitute with 2 mL water for injections or sodium chloride 0.9%	Adult 100 mg	stat
			Child 6–11 years and child 1–5 years with severe wheeze 4 mg/kg (max. 100 mg)	Inject over 30 seconds to 5 minutes. Further doses as per MO/NP
Offer CMI: May cause ↑ BGL and affect mood and sleep				
Management of associated emergency: Consult MO/NP. See Anaphylaxis, p. 82 1,7,8				

5. Follow up¹

- Advise to return the following day for review, or sooner if concerned/needing to use salbutamol more than 4 hourly. If returns earlier consult MO/NP
- On review the next day:
 - if wheeze/other symptoms present consult MO/NP
 - if no wheeze present advise to be reviewed at next MO/NP clinic and again in 2–4 weeks
- Patients, relatives and friends of people with asthma should have an Asthma Action Plan + know asthma first aid <https://www.asthmahandbook.org.au/>

6. Referral/consultation¹

- Consult MO/NP as above

Drowning/submersion - adult/child

Recommend^{1,2}

- Ventilation + oxygenation to reverse hypoxia
- Active rewarming is not routinely recommended. May lead to rapid overshoot of core T

Background

- If child, also see *Drowning - emergency management in children* <https://www.childrens.health.qld.gov.au/qpec-statewide-guidelines/>

1. May present with

- Immersion ± vomiting, respiratory compromise, apnoea or in cardiac arrest^{1,3}
- Suspect spinal injury if history indicates eg dived into shallow water, found near dumping surf, rocks or after boating accident²

2. Immediate management

- Rapidly assess + manage concurrently¹
- **DRSABCD** + **BLS**, p. 46 as needed. **Note:** if hypothermia do prolonged CPR
- Assess patient on back with head + body at same level:
 - not head down - risk of regurgitation + vomiting²
 - only roll on side if airway obstructed, reassess condition after rolling²
 - **c-spine immobilisation**, p. 147 if spinal injury suspected
- If breathing, place on side + open airway eg head tilt²
- Do:
 - vital signs + **GCS**, p. 562
 - BGL
 - continuous cardiac monitoring
- **Consult MO/NP urgently**
- If SpO₂ < 95% + respiratory compromise eg ↑ WOB:¹
 - give O₂ to maintain SpO₂ ≥ 95% in adults + children
 - if unable to maintain SpO₂ with O₂ + adequate conscious state (GCS 13–15):
 - consider non-invasive ventilation eg **CPAP**, p. 55¹
- Remove wet clothing, dry + keep warm with blankets²

3. Clinical assessment

- Ask about:¹
 - circumstances leading to the drowning, duration of immersion
 - resuscitation, length of CPR + drugs given
 - witnesses
 - fresh or salt water, contaminated eg agricultural, sewage

- If cause of drowning not clear, ask about:¹
 - epilepsy
 - personal + family history of arrhythmias
 - diabetes
 - drug + alcohol use
 - dementia²
- Do physical examination, including:¹
 - listen to chest - any crackles, wheeze, chest x-ray if available
 - ECG
 - if distended stomach do not try to empty by applying external pressure²
 - check for other injuries. Avoid prolonged exposure to prevent heat loss
- Consider non-accidental injury or neglect if child with inconsistent histories, an obvious lapse in supervision, a delay in seeking care or other injuries eg bruises, old fractures.¹ See [Child protection, p. 551](#)

4. Management

- MO/NP may advise:¹
 - IV/[Intraosseous, p. 57](#) sodium chloride 0.9%, if child 20 mL/kg
 - IV antibiotics if grossly contaminated water
 - insert IDC, nasogastric tube
 - bloods/i-STAT ± blood gas
 - evacuation/hospitalisation - **early contact with retrieval service is advised**
- Monitor closely until evacuation:^{1,2}
 - continue O₂ + encourage to cough + take deep breaths
 - keep warm
 - vital signs + strict fluid balance
- If patient initially appears well, they may still deteriorate due to pulmonary oedema:
 - observe for 4–8 hours before considering discharge in collaboration with MO/NP^{1,3}

5. Follow up

- As per MO/NP

6. Referral/consultation

- A person in charge of a hospital is required to notify Qld Health of any immersions of a child < 5 years in a swimming pool.¹ See <https://www.health.qld.gov.au/public-health/notifiable-incidents-conditions/pool-immersion-reporting> or refer to local policy if outside of Qld

Cardiovascular emergencies

Chest pain assessment

Recommend

- Chest pain assessment is time critical¹
- Use cardiac clinical pathways. Ensure they are readily available.^{2,3} In Qld see <https://clinicalexcellence.qld.gov.au/resources/clinical-pathways/cardiac-clinical-pathways>
- ECG Flash is available in some Qld remote facilities <https://qheps.health.qld.gov.au/caru/networks/cardiac/ecg-flash>
- Do not use gastrointestinal (GI) cocktails eg 'pink lady' (oral viscous lidocaine (lignocaine), antacid ± anticholinergic) to assist in ruling out coronary ischemia^{4,5}

1. May present with¹

- Chest pain or discomfort

2. Immediate management¹

- Aim to identify **Acute coronary syndrome**, p. 107 or other life-threatening conditions
- **Do rapid assessment:**
 - general appearance
 - vital signs
 - allergies
 - **ECG** - to be reviewed by MO/NP **within 10 minutes of presentation:**
 - if difficult to interpret, MO/NP may send to cardiologist using **ECG Flash** if available
- **Ask about the pain and symptoms:**^{1,6}
 - **Site** - central chest, left chest, epigastric, shoulder/back, jaw, neck, arm
 - **Onset** - when did it start, sudden or gradual, is it present now
 - **Characteristics** - discomfort, pressure, tightness, heaviness, cramping, band like, burning, ache, sharp, dull, stabbing, fullness, squeezing, tearing, ripping
 - **Radiation** - to neck, jaw, shoulder, one or both arms, into hands and wrists, back
 - **Associated symptoms:**
 - SOB
 - nausea, vomiting, sweating
 - dizziness/light-headedness, fainting
 - fever, cough with purulent or pink frothy sputum or blood
 - **Timing:**
 - constant or intermittent
 - ever had this pain before, how often does it occur, how long did it last
 - **Exacerbating or relieving factors:**
 - what brought on pain eg activity, foods, cold, stress, trauma
 - what makes it better/worse eg rest, medicines (GTN, antacids), eating, position changes, deep inspiration, movement, cough, laugh
 - any analgesia taken, effect
 - **Severity** - scale of 0–10, with 0 being none and 10 being the worst
- **Use flowcharts on next page to help with differential diagnosis** - note, these flowcharts do not include all causes of chest pain

Life-threatening causes of chest pain^{1,6}**Acute coronary syndrome^{1,7}**

If possible cardiac chest pain ± other symptoms of myocardial ischaemia, go immediately to [ACS, p. 107](#)

- Heaviness/pressure/tightness/squeezing/burning pain:
 - central chest - may radiate to arm, neck, jaw
 - duration ≥ 10 minutes
 - ± triggered by exertion, emotional stress, temperature extremes
- **Other symptoms** eg SOB, nausea/vomiting, sweating, unexplained fatigue, syncope/fainting, dizziness, SOB when lying down
- **Atypical symptoms** ie symptoms without pain. More common in elderly, women, renal failure, diabetes, Aboriginal and Torres Strait Islander people

Pulmonary embolism⁶

Contact MO/NP urgently
Go to [PE, p. 125](#)

- Sudden onset
- SOB - most common symptom
- Sharp, pleuritic pain
- Cough, fainting
- Consider if:
 - symptoms of [DVT, p. 124](#) eg calf swelling/pain in 1 leg
 - pregnant/postnatal women, HRT
 - hospitalised within previous 3 months
 - a period of inactivity eg long-distance travel
 - history of cancer - other than skin cancer
 - bone fracture

Aortic dissection (rare)⁶

Contact MO/NP urgently

- Sudden onset of severe chest ± back pain:
 - sharp, ripping, tearing, stabbing
 - can radiate anywhere in chest or abdomen
- Pulse deficits ie ↓ flow to peripheral vessels
- Commonly associated with hypertension or connective tissue disorder
- Fainting, ↓ BP, shock
- sBP may be different on each arm of > 20

Tension pneumothorax⁶

Go to [Chest injuries, p. 140](#)

- History of trauma
- ↑ respiratory distress, ↑ HR, ↓ BP
- Unequal chest movement, ↓ air entry

Pericardial tamponade⁶

Contact MO/NP urgently

- Dizziness, SOB, fatigue, ↓ BP, ↑ HR
- Features of pericarditis:
 - sharp/pleuritic pain - worse when lying down. Improved by sitting up and leaning forward
 - dry cough, fever, muscle/joint pain
 - pericardial friction rub - superficial scratchy or squeaking sound on auscultation
 - new wide spread ST elevation or PR depression
- Cardiogenic [Shock, p. 62](#)

Non-immediate life-threatening causes of chest pain⁶

Spontaneous pneumothorax⁶

- Sudden onset unilateral pleuritic chest pain
- SOB, absent breath sounds, ↑ resonance to percussion
- ↑HR, hypoxia

Musculoskeletal causes⁶ eg rib fracture(s) from coughing, stress fracture

- Pain/tenderness on palpation
- Pain on inspiration, movement of chest or upper body

Pneumonia⁶

See [Pneumonia - adult, p. 253](#)

- Pleuritic pain, fever, productive or dry cough
- ↑RR, ↓breath sounds, crackles, wheeze
- Night sweats, rigors

Acute bronchitis⁸

See [URTI - adult, p. 250](#)

- Cough, worse at night or with exercise
- Low grade fever, wheeze
- Smoking history ± close contact with infected person

Lung cancer⁶

- Chest discomfort, typically on side of tumour
- Persistent cough, coughing up blood
- SOB, hoarseness
- Smoking history, symptoms > 30 days, weight loss

Gastrointestinal causes⁶

See [Abdominal pain, p. 196](#)
See [Gastritis, p. 202](#)

- Heartburn, regurgitation, dysphagia, precipitated by meal, fatty foods, bending down, or lying down
- Retrosternal without radiation
- Epigastric pain, relieved by antacid or food
- GORD may mimic angina

3. Clinical assessment^{1,6}

- Get past history, including prior:
 - presentation/admission to hospital/clinic with chest pain within 28 days³
 - cardiac investigations eg stress test, exercise ECG, coronary CT angiography
 - heart disease, previous myocardial infarction
- Ask about cardiovascular risk factors:³
 - ↑cholesterol
 - hypertension, diabetes
 - smoking - cigarettes/day, years smoking, quit date
 - obesity - weight, BMI
 - family history
 - chronic kidney disease - stage
- Also ask about:
 - current medicines + aspirin, anticoagulants
 - lung disease
 - cancer
 - alcohol, recreational drug use eg cocaine, amphetamines
 - diet

- recent events eg:
 - pregnancy, trauma, major surgery or medical procedures
 - periods of immobilisation, long-distance travel
 - illness, fever, malaise
 - strenuous physical activity
- Do physical examination, including:
 - BP on both arms - if concern for aortic dissection
 - inspect and auscultate chest ± heart sounds if skilled
 - palpate abdomen. See [Abdominal pain, p. 196](#)
- Chest x-ray may be ordered by MO/NP to assist in differential diagnosis⁶

4. Management

- For all patients with suspected cardiac causes of chest pain see [ACS, p. 107](#)
- Urgently contact MO/NP if severe or life-threatening symptoms
- Consult MO/NP for all other presentations of chest pain

5. Follow up

- Be guided by MO/NP

6. Referral

- Always consult MO/NP

HMP Acute coronary syndrome (ACS) - adult

Possible cardiac chest pain, unstable angina, myocardial infarction

Recommend^{1,2}

- Evacuation/treatment of ACS is time critical
- **Use cardiac clinical pathways.** Ensure they are readily available²
 - In Qld <https://clinicalexcellence.qld.gov.au/resources/clinical-pathways/cardiac-clinical-pathways>
 - *Suspected acute coronary syndrome clinical pathway*
 - *Acute coronary syndrome clinical pathway*
 - *Thrombolysis for STEMI clinical pathway*
- Elevated troponin alone (without cardiac symptoms) should not trigger the urgent treatment of ACS. Troponin may be elevated in many conditions, including sepsis³ and PE.¹ Urgently consult MO/NP in all cases

Background¹

- ACS includes myocardial infarction (MI) or unstable angina:
 - MI can be ST elevation (STEMI) or non-ST elevation (NSTEMI)
 - patients without ST elevation are initially described as having NSTEMACS (non-ST elevation acute coronary syndrome) until investigated further
- Reperfusion is restoring the flow of blood to the heart

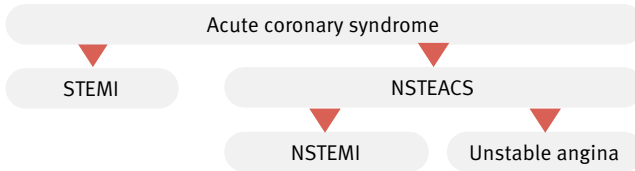

1. May present with^{1,4}

- **Chest discomfort or pain:**
 - heaviness/discomfort/pressure
 - aching, numbness
 - tightness/fullness
 - squeezing/burning
 - can radiate to shoulder, arm, jaw, back, or upper abdominal area
 - duration \geq 10 minutes
 - typically triggered eg by exertion, emotional stress, temperature extremes OR can occur at rest
- **Associated symptoms:**
 - SOB or difficulty breathing \pm chest discomfort
 - dizziness, light-headedness, feeling faint or anxious
 - nausea, vomiting, indigestion
 - sweating/cold sweat
 - lethargy/fatigue
- **Consider atypical presentation:**
 - associated symptoms WITHOUT chest pain
 - especially if diabetes, renal failure, female, elderly or Aboriginal and Torres Strait Islander person⁵

2. Immediate management^{1,5}

Use *Suspected acute coronary syndrome clinical pathway*
<https://clinicalexcellence.qld.gov.au/resources/clinical-pathways/cardiac-clinical-pathways>
 or local pathway(s) if outside Qld

- **Get rapid history** of chest pain as per [Chest pain assessment, p. 103](#)
 - site, onset, characteristics, radiation, associated symptoms, timing, exacerbating or relieving factors, severity
 - other [Life-threatening causes of chest pain, p. 104](#) eg aortic dissection, PE, must be considered¹
- **Do ECG + vital signs:**
 - send for **urgent review by MO/NP within 10 minutes** of first patient contact
 - if difficult to interpret, MO/NP may send to cardiologist using [ECG Flash](#) if available. See <https://qheps.health.qld.gov.au/caru/networks/cardiac/ecg-flash>
- **Give aspirin** as soon as possible (if not contraindicated/already given)
- **Give subling glyceryl trinitrate (GTN)** if no contraindications:
 - repeat every 5 minutes for ongoing chest pain or discomfort (aim for no pain)
 - up to 3 doses
- **Insert IVC x 2**
- **Take blood for troponin - i-STAT**
- **If symptoms not relieved with GTN** or for ongoing chest discomfort at any time during initial management:
 - give IV fentanyl or morphine - titrate to pain. See [Acute pain, p. 32](#) for doses
 - **note:** opioids may delay absorption of clopidogrel and ticagrelor⁶
- **Give antiemetic if needed.** See [Nausea and vomiting, p. 40](#)
- **Continuous cardiac monitoring**
- If SpO₂ < 93% or evidence of shock give O₂
 - use with caution if COPD. Aim for SpO₂ 88–92% if known CO₂ retainer
 - titrate O₂ to SpO₂
- **Repeat ECG every 10–15 minutes** until pain free
- MO/NP may order chest x-ray

S2	Aspirin			Extended authority ATSIHP/IHW
ATSIHP, IHW, RIPRN and RN may proceed				
Form	Strength	Route	Dose	Duration
Dispersible tablet	300 mg	Oral	300 mg Chewed or dissolved in water	stat
Offer CMI: May cause GI irritation or bleeding				
Contraindication: Allergy to aspirin or NSAIDs, aspirin sensitive asthma, active or high risk of internal bleeding, or major bleeding				
Management of associated emergency: Consult MO/NP. See Anaphylaxis, p. 82				5:7

S ₃	Glyceryl trinitrate (GTN)			Extended authority ATSIHP/IHW
ATSIHP, IHW, RIPRN and RN may proceed				
Form	Strength	Route	Dose	Duration
Tablet	600 microg	Subling	300–600 microg	stat
Spray	400 microg/spray		400–800 microg	Repeat every 5 minutes up to 3 doses providing sBP \geq 90
Offer CMI: May cause headache, flushing, palpitations, hypotension, dizziness or fainting. Advise to get up gradually from sitting or lying				
Note: Sit or lie before giving. Do not use tablets from bottles that have been opened > 3 months. If unopened spray, prime by pressing nozzle 5 times into the air, or if > 7 days since used, press once				
Contraindication: Hypotension (sBP < 90), patient has taken phosphodiesterase-5-inhibitors eg sildenafil (eg Viagra®), vardenafil (Levitra®) \leq 24 hours or tadalafil (eg Cialis®) \leq 48 hours				
Management of associated emergency: Consult MO/NP. See Anaphylaxis, p. 82 5,8				

3. Clinical assessment⁵

- MO/NP will assess if reperfusion indicated - with cardiologist advice if needed
- Use *Suspected acute coronary syndrome clinical pathway*/local pathway if outside of Qld (summarised below)

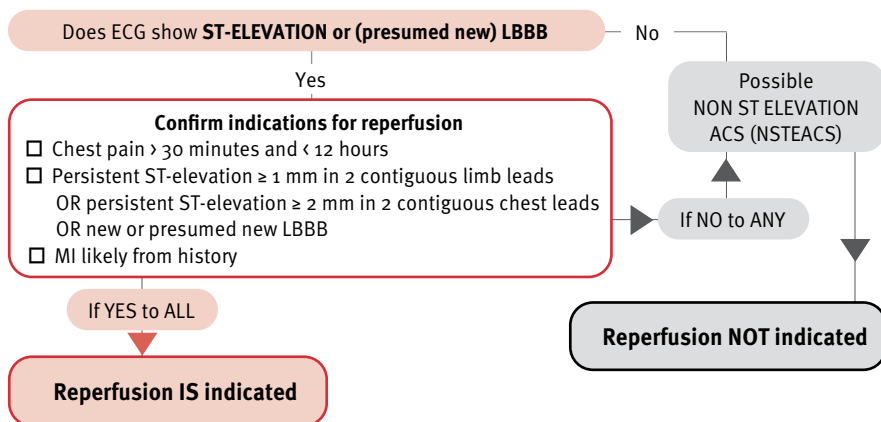

4. Management

- **If reperfusion IS indicated** - arrange urgent evacuation:
 - **OPTION 1, p. 110**
 - if access to a cardiac lab for stent (primary PCI) **IS possible within \leq 90 minutes** of first diagnostic ECG - MO/NP to immediately contact on call interventional cardiologist
 - **OPTION 2, p. 110**
 - if primary PCI **is NOT possible within \leq 90 minutes** of first diagnostic ECG - assess for thrombolysis at rural or remote facility
- **If reperfusion NOT indicated** - see **OPTION 3, p. 112**

OPTION 1: Urgent evacuation for stent (primary PCI)⁵

- STEMI + reperfusion indicated + **ABLE** to access cardiac lab within 90 minutes

Use *Suspected acute coronary syndrome clinical pathway*
<https://clinicalexcellence.qld.gov.au/resources/clinical-pathways/cardiac-clinical-pathways>
 or local pathway(s) if outside Qld

- MO/NP will urgently:
 - contact on call interventional cardiologist
 - arrange urgent evacuation
 - order **antithrombotic therapy**:
 - aspirin 300 mg - if not already given
 - ticagrelor 180 mg oral - or alternative if advised by interventional cardiologist
 - enoxaparin OR unfractionated heparin/heparin sodium - to confirm with interventional cardiologist
- Continuous cardiac monitoring
- Frequently monitor vital signs
- Continue to liaise with MO/NP for further management until evacuation

OPTION 2: Thrombolysis at rural or remote facility⁹

- STEMI + reperfusion indicated + **NOT ABLE** to access cardiac lab within 90 minutes

Use *Thrombolysis for STEMI clinical pathway*
<https://clinicalexcellence.qld.gov.au/resources/clinical-pathways/cardiac-clinical-pathways>
 or local pathway(s) if outside Qld

MO/NP to assess if suitable for thrombolysis at rural or remote facility

Check for **Contraindications for thrombolysis**

Absolute contraindications	Relative contraindications
<ul style="list-style-type: none"> <input type="checkbox"/> Active bleeding or bleeding tendency (excluding menses) <input type="checkbox"/> Suspected aortic dissection <input type="checkbox"/> Significant closed head or facial trauma ≤ 3 months <input type="checkbox"/> Any prior intracranial haemorrhage <input type="checkbox"/> Ischaemic stroke ≤ 3 months <input type="checkbox"/> Known cerebral vascular lesion <input type="checkbox"/> Known malignant intracranial neoplasm 	<ul style="list-style-type: none"> <input type="checkbox"/> Current anticoagulants, including novel anticoagulant agents <input type="checkbox"/> Non-compressible vascular puncture <input type="checkbox"/> Recent major surgery (< 3 weeks) <input type="checkbox"/> Traumatic or prolonged (> 10 minutes) CPR <input type="checkbox"/> Recent internal bleeding - within 4 weeks/active peptic ulcer <input type="checkbox"/> Suspected pericarditis <input type="checkbox"/> Advanced liver disease/advanced metastatic cancer <input type="checkbox"/> History of chronic, severe, poorly controlled hypertension <input type="checkbox"/> Severe uncontrolled hypertension on this presentation - systolic BP > 180 or diastolic BP > 110 <input type="checkbox"/> Ischaemic stroke > 3 months ago, known intracranial abnormality (not covered in absolute contraindications)/dementia <input type="checkbox"/> Pregnancy or ≤ 1 week postpartum

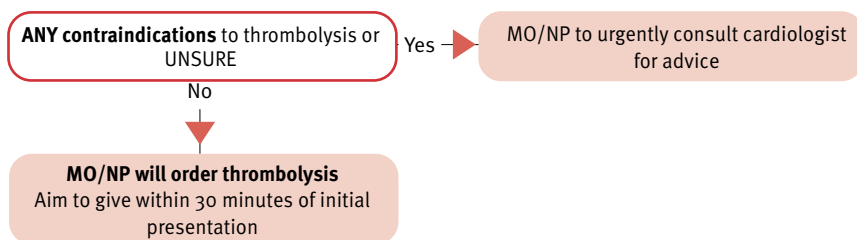

Pre thrombolysis

- Informed verbal consent required
- Insert IVC x 2 if not in situ
- Record baseline:
 - vital signs + continuous cardiac monitoring
 - circulation observations ie for bleeding
 - neurological observations - [GCS, p. 562](#)
- Weigh patient

Thrombolysis medication

- **Note:** patient should be monitored by staff trained in ALS with access to a defibrillator:
 - significant arrhythmias including VF can occur after reperfusion - have pads on chest
- On MO/NP order ONLY, give:
 - aspirin 300 mg - if not already given
 - clopidogrel 300 mg - orally
 - tenecteplase - IV bolus as per weight adjusted dose guide - consider ½ dose if ≥ 75 years old
 - enoxaparin (if severe renal failure, MO/NP may order unfractionated heparin/heparin sodium):
 - if < 75 years - loading dose 30 mg IV. **Omit loading dose if > 75 years**
 - 15 minutes after loading dose, give 1 mg/kg subcut (max. 100 mg)

S4	Tenecteplase					Prescribing guide	
RIPRN and RN only. Must be ordered by an MO/NP							
Form	Strength	Route	Dose			Duration	
Injection	40 mg (8,000 units)	IV Reconstitute with diluent provided Reconstituted strength = 5 mg/mL (1,000 units/mL) <i>Swirl to dissolve do not shake</i>	Weight	units	mg	mL	stat
			< 60 kg	6,000	30	6	Inject over 10 seconds
	$\geq 60 - < 70$ kg		7,000	35	7		
	50 mg (10,000 units)		$\geq 70 - < 80$ kg	8,000	40	8	Flush line before and after with sodium chloride 0.9%
			$\geq 80 - < 90$ kg	9,000	45	9	
≥ 90 kg	10,000	50	10				
Offer CMI: May cause bleeding at injection sites, intracerebral bleeding, internal bleeding eg GI/genitourinary or transient hypotension							
Note: If ≥ 75 years old, consider ½ dose to ↓ risk of intracranial bleeding							
Contraindication: See Contraindications for thrombolysis, p. 110 . Severe active bleeding disorders or disease states with an increased risk of bleeding. Allergy to gentamicin							
Management of associated emergency: Contact MO/NP. See Shock, p. 62/Anaphylaxis, p. 82 ⁹⁻¹¹							

S4	Enoxaparin (Clexane®)			Prescribing guide
RIPRN and RN only. Must be ordered by an MO/NP				
Form	Strength	Route	Dose	Duration
Prefilled syringe	60 mg/0.6 mL 80 mg/0.8 mL	IV*	Loading dose (< 75 years)[#] 30 mg Expel air bubble and excess enoxaparin before injecting	stat Loading dose Flush line before and after injection with sodium chloride 0.9%
		Subcut	Maintenance dose < 75 years 1 mg/kg (max. 100 mg) ≥ 75 years 0.75 mg/kg (max. 75 mg) Do not expel air bubble	Maintenance dose Give 15 minutes after loading dose
Offer CMI: May cause bleeding, bruising or pain at injection site				
Note: [#] Omit loading dose if ≥ 75 years. *Use Microbore® extension set (or similar) to give IV enoxaparin (has a Y-injection port to put needle in). See QAS procedure <i>Priming of a Microbore extension set</i> https://www.ambulance.qld.gov.au/CPPTable.html				
Contraindication: Use with caution if severe hepatic or renal impairment (heparin preferred)				
Management of associated emergency: Contact MO/NP. See Shock, p. 62 / Anaphylaxis, p. 82 ^{9,12-14}				

Post thrombolysis

- Prepare for urgent evacuation to PCI capable hospital:
 - send copies of ECGs with other documentation
 - keep under direct observation of RN until evacuated
- Continuous cardiac monitoring:
 - be alert to arrhythmias including VF
- Monitor frequently:
 - vital signs
 - circulation and neurological observations - to detect bleeding¹
- Repeat ECG at 30 minutes, 60 minutes and 90 minutes - to be reviewed by MO/NP
- Continuously liaise with MO/NP
- **If failed reperfusion:**
 - ie unresolved pain and ST elevation has not reduced > 50% at 60 minutes
 - MO/NP will urgently consult on call interventional cardiologist for further advice

OPTION 3: Reperfusion NOT indicated⁵

- Possible NSTEMI or STEMI + does not meet criteria for reperfusion

Use *Suspected acute coronary syndrome clinical pathway* AND *Acute coronary syndrome pathway* <https://clinicalexcellence.qld.gov.au/resources/clinical-pathways/cardiac-clinical-pathways> or local pathway(s) if outside Qld

- MO/NP will:
 - risk stratify as per the *Suspected acute coronary syndrome clinical pathway*
 - if patient is high risk commence *Acute coronary syndrome pathway*
- Be guided by MO/NP for further management, which may include:⁵
 - urgent evacuation to cardiac interventional facility
 - continuous cardiac monitoring
 - repeat ECGs

- repeat troponin in 3 hours (laboratory) **or** 6–8 hours (i-STAT) after presentation +
 - CHEM20, FBC, coagulation studies, HbA1C, lipid profile
- BGL
- frequent monitoring of:
 - vital signs
 - circulation and neurological observations
 - SpO₂
- **If assessed as low risk**, MO/NP may advise patient can be discharged home if:
 - repeat ECG normal
 - repeat troponin negative at 3 hours (laboratory) or 6–8 hours (i-STAT)
 - no further chest pain

5. Follow up

- As directed by MO/NP

6. Referral/consultation

- Consult MO/NP on all occasions of chest pain
- May require further investigations eg angiography, echo, stress test

HMP Acute pulmonary oedema (cardiac causes) - adult

Recommend¹

- **Acute pulmonary oedema (APO) is a medical emergency.** It is the rapid accumulation of fluid in the alveoli from the pulmonary circulation. Fluid impairs gas exchange and decreases lung compliance leading to difficulty breathing and hypoxia

Background

- Causes can be ACS, valve dysfunction. **Note:** can be non-cardiac causes eg sepsis, drowning

Related topics

[Hypertensive emergency, p. 116](#)
[ACS, p. 107](#)

[Sepsis, p. 64](#)
[Drowning, p. 101](#)

1. May present with^{1,2}

- Sudden onset of extreme breathlessness. May wake patient up at night
- Anxiety/agitation
- Pale/ashen, sweaty
- Lung crackles
- Cough (pink frothy sputum in severe cases)
- Chest pain
- Cyanosis (late sign), exhaustion, altered LOC
- Tripod position (sit/standing leaning forward, supporting upper body with hands on knees/other surface, indicating respiratory distress)
- Oedema of legs/sacrum and an enlarged liver may co-exist as a sign of right heart failure

2. Immediate management^{1,2}

- **DRSABCD.** Be prepared for rapid deterioration ± cardiorespiratory arrest
- Call for help
- **Sit patient as upright as possible** - do not lay them down
- **Consult MO/NP urgently** + urgent evacuation
- Do vital signs +
 - capillary refill time
 - LOC. See [GCS/AVPU, p. 562](#)
 - continuous cardiac monitoring
- Give O₂ if SpO₂ < 94%. Titrate O₂ to SpO₂
 - use with caution if COPD. Aim for SpO₂ 88–92%
- **Insert IVC x 2** eg 16 G
- **Take bloods** - i-STAT (CHEM8+, VBG, troponin) + FBC, TSH
- **Give:**²
 - sublingual glyceryl trinitrate (GTN) providing sBP > 110. Give 2–5 minutely being guided by clinical response AND
 - IV furosemide (frusemide)
- **Do ECG** - review by MO/NP within 10 minutes

3. Clinical assessment^{1,2}

- **Get rapid history**, including:
 - **Allergies**
 - **Medicines** - are they taken correctly
 - **Past history:**
 - heart problems eg angina, MI, heart failure, palpitations, RHD, arrhythmias
 - hypertension, renal failure, COPD, diabetes
 - alcohol/drug use
 - recent infection
 - currently pregnant²
 - Last ate
 - **Events related:**
 - onset, any chest pain
 - other signs/symptoms
 - recent ↑ weight
- **Do physical examination**, including:
 - general appearance eg ashen/cyanosed, sweaty, WOB
 - skin temperature - compare trunk with limbs; are peripheries cool
 - auscultate chest - crackles, wheeze, air entry
 - weight (if able)
 - oedema - check legs/ankles + if able sacrum (with patient sitting up and forward)
- Chest x-ray if MO/NP requests

4. Management^{1,2}

- MO/NP may order:
 - GTN infusion - titrate to BP and clinical effect:
 - see [Hypertensive emergency, p. 116](#) for drug box
 - **if infusion not practical in the rural/remote area**, GTN transdermal patch(es)³

- + other treatment specific to cause (if known)²
- Monitor closely until evacuation:²
 - airway, LOC, vital signs, SpO₂
 - cardiac monitoring
 - symptoms
 - urine output. IDC not routinely recommended. **Do not lie patient down in APO**

If no improvement/deteriorating, MO/NP may consider:

- **Non invasive ventilation** - CPAP, p. 55 (or BiPAP if CPAP not available):
 - monitor for nausea/vomiting as ↑ risk of aspiration while mask in place due to altered LOC
 - although morphine not routinely recommended for APO, if patient anxious/distressed or not tolerating CPAP, MO/NP may consider:²
 - IV morphine 1–2.5 mg - single dose. Use cautiously as may ↑ need for ventilation²
 - if given, monitor nausea, RR/depth and LOC. See [Sedation score, p. 35](#)
- **Intubation** if still continues to deteriorate + skilled staff eg:
 - exhaustion, ↓ LOC, ↑ confusion/agitation
- **CPR if needed.** See [ALS, p. 48](#)

S3	Glyceryl trinitrate (GTN)			Extended authority ATSIHP/IHW
ATSIHP, IHW, RIPRN and RN may proceed				
Form	Strength	Route	Dose	Duration
Tablet	600 microg	Subling	300–600 microg	stat
Spray	400 microg/ spray		1–3 sprays (400–1200 microg)	Repeat every 2–5 minutes provided sBP ≥ 110 If no improvement consult MO/NP - may need higher doses
Offer CMI: May cause headache, flushing, palpitations, hypotension, dizziness or fainting. Advise to get up gradually from sitting or lying				
Note: Sit before giving. Do not use tablets from bottles that have been opened > 3 months. If unopened spray, prime by pressing nozzle 5 times into the air, or if > 7 days since used, press once				
Contraindication: Hypotension (sBP < 90), patient has taken phosphodiesterase-5-inhibitors eg sildenafil (eg Viagra®), vardenafil (Levitra®) ≤ 24 hours or tadalafil (eg Cialis®) ≤ 48 hours				
Management of associated emergency: Consult MO/NP. See Anaphylaxis, p. 82 1,2,4				

S4	Furosemide (frusemide)			Extended authority ATSIHP/IHW/RIPRN
ATSIHP, IHW and RN must consult MO/NP				
RIPRN must consult MO/NP unless circumstances do not allow, in which case give up to 40 mg and notify the MO/NP as soon as circumstances allow				
Form	Strength	Route	Dose	Duration
Injection	20 mg/ 2 mL	IV	20–40 mg OR if patient already taking oral furosemide, give at least equivalent dose IV*	stat Give undiluted over 2–5 minutes Repeat in 20 minutes if needed on MO/NP order
Offer CMI: May cause dizziness, fainting or dehydration				
Note: Check BP first - check with MO/NP if hypotensive. *If > 80 mg required, give via slow IV infusion to reduce risk of ototoxicity				
Management of associated emergency: Consult MO/NP. See Anaphylaxis, p. 82 1,2,5,6				

S4	Glyceryl trinitrate (GTN)			Extended authority ATSIHP/IHW/IPAP	
ATSIHP, IHW, IPAP, RIPRN and RN must consult MO/NP					
Form	Strength		Route	Dose	Duration
Patch	5 mg/24 hours =	1 x Minitran 5 OR 1 x Transiderm Nitro 25	Transdermal	5–15 mg Apply to clean, dry skin on the chest area or upper arm	stat note: remove before defibrillation
	10 mg/24 hours =	1 x Minitran 10 OR 1 x Transiderm Nitro 50			
Offer CMI: As per subling GTN. Write date and time of patch application on patch itself when placing on patient					
Contraindication: As per subling GTN					
Management of associated emergency: Consult MO/NP. See Anaphylaxis, p. 82					

4

5. Follow up

- As per MO/NP

6. Referral/consultation

- Consult MO/NP as above

HMP Hypertensive emergency - adult

1. May present with^{1,2}

- BP $\geq 180/110 \pm$
 - headache, dizziness, visual disturbances
 - SOB, lung crackles, nausea, vomiting
 - chest pain
 - altered LOC, [Stroke, p. 130](#) (\downarrow sensation, movement)
 - \downarrow urine output

2. Immediate management¹⁻³

- Do pregnancy test if female of reproductive age. If +ve, see [Hypertension in pregnancy, p. 383](#)
- If trauma related, urgently contact MO/NP
- Do vital signs +
 - check BP on both arms (+ a lower limb if [Aortic dissection, p. 104](#) suspected)¹
 - if automated BP machine, check manually
- Get rapid history, including:¹
 - allergies
 - any chest pain, SOB, headache, visual change, neurological symptoms
 - recent drug use eg cocaine, ice/amphetamines
 - medicines - for BP, aspirin, anticoagulants, other (are they taken correctly)
 - past medical history - prior \uparrow BP, heart problems, renal disease, aneurysm
- **Rapidly assess severity** and manage as per table (next page)

Rapidly assess severity^{1,2}

Severely elevated BP ¹	Hypertensive urgency ¹	Hypertensive emergency ¹
<ul style="list-style-type: none"> • BP \geq 180/110 • No symptoms • No signs of acute organ damage¹ 	<ul style="list-style-type: none"> • BP \geq 180/110 • Persistently elevated BP • Minor symptoms eg headache, dizziness 	<ul style="list-style-type: none"> • High BP - often $>$ 200/120, but may be lower • PLUS symptoms of acute organ damage eg: <ul style="list-style-type: none"> - SOB/signs of APO, p. 113 - altered LOC/stroke - seizures, lethargy, vision changes - \downarrow urine output - chest pain - aortic dissection

Do not usually need immediate treatment

If patient already on BP medicine and has not taken, give usual dose

Consult MO/NP who may advise¹

- Observe and re-check BP several times over 1–2 hours to see if it settles
- Initiating or \uparrow oral anti-hypertensive medication
- Home with follow up over next 2–3 days to see if BP reduces + review at next MO/NP clinic
- Or hospitalisation if risk factors/concerns

If patient already on BP medicine and has not taken, give usual dose

Urgently consult MO/NP who may advise¹

- If not on BP medicine give oral anti hypertensive eg nifedipine (**slow release**)¹ or amlodipine
- Aim for a slow controlled reduction of BP¹
- Monitor BP and symptoms for at least 2 hours¹
- If sBP reduced (ideally $<$ 160) AND symptoms gone, may consider home with review next day
- Or hospitalisation/evacuation if symptoms ongoing, BP difficult to control, or risk factors/concerns

Life-threatening

Urgently consult MO/NP who may advise¹

- Urgent evacuation
- **BP 5 minutely**
- \pm medicine as per cause
- It may be harmful to \downarrow BP too rapidly or too much
- MO/NP may seek specialist advice for target BP
- Insert IVC x 2
- Continue BP 5 minutely until stabilises

Hypertensive emergency - on MO/NP order only ¹		BP reduction rate/target ¹
Acute pulmonary oedema	<ul style="list-style-type: none"> • Subling/IV GTN or patch if IV not available in rural or remote area.⁴ • See APO, p. 113 	<ul style="list-style-type: none"> • Immediate reduction of BP • Aim for sBP $<$ 140
Acute coronary event		
Stroke	<ul style="list-style-type: none"> • MO/NP may seek specialist advice 	<ul style="list-style-type: none"> • Avoid aggressive BP reduction - can worsen ischaemic stroke¹
Aortic dissection	<ul style="list-style-type: none"> • Beta blocker eg esmolol • Subling/IV GTN • Analgesia¹ 	<ul style="list-style-type: none"> • Immediate reduction of BP and HR • Aim for sBP $<$ 120 and HR $<$ 60
Hypertensive encephalopathy	<ul style="list-style-type: none"> • IV labetalol if available • MO/NP may seek specialist advice • Aim to \downarrow mean arterial pressure by 20–25% 	<ul style="list-style-type: none"> • Immediate reduction of BP • Reduce BP over several hours
Malignant hypertension ie advanced retinopathy		
Adrenergic crisis		

S3	Glyceryl trinitrate (GTN)			Extended authority ATSIHP/IHW
ATSIHP, IHW, RIPRN and RN must consult MO/NP				
Form	Strength	Route	Dose	Duration
Tablet	600 microg	Subling	300–600 microg	stat
Spray	400 microg/ spray		1–3 sprays (400–1200 microg)	Repeat every 2–5 minutes until desired BP obtained
Offer CMI: May cause headache, flushing, palpitations, hypotension, dizziness or fainting. Advise to get up gradually from sitting or lying				
Note: Sit before giving. Do not use tablets from bottles that have been opened > 3 months. If unopened spray, prime by pressing nozzle 5 times into the air, or if > 7 days since used, press once				
Contraindication: Hypotension (sBP < 90), patient has taken phosphodiesterase-5-inhibitors eg sildenafil (eg Viagra®), vardenafil (Levitra®) ≤ 24 hours or tadalafil (eg Cialis®) ≤ 48 hours				
Management of associated emergency: Consult MO/NP. See Anaphylaxis, p. 82 1,2,5				

S4	Glyceryl trinitrate (GTN)			Prescribing guide
RIPRN and RN only. Must be ordered by an MO/NP. Use local protocol if available				
Form	Strength	Route	Dose	Duration
Injection	50 mg/ 10 mL	IV	Start infusion 10 microg/minute	Infusion As per MO/NP instruction
		Dilute to 500 mL in sodium chloride 0.9% to make a concentration of 100 microg/mL	Titrate until target BP reached Increase by 5 microg/minute, every 5 minutes (max. 100 microg/minute)	
Offer CMI: May cause headache, flushing, palpitations, hypotension, dizziness or fainting. Advise to get up gradually from sitting or lying				
Note: GTN is absorbed onto some plastics. Use glass or non-PVC containing bottle or bag eg Braun Ecoflac®. Onset of action: 1–2 minutes. Duration of effect: 3–5 minutes				
Contraindication: Hypovolaemia, hypotension (sBP < 90), raised ICP, patient has taken phosphodiesterase-5-inhibitors eg sildenafil (eg Viagra®), vardenafil (Levitra®) ≤ 24 hours or tadalafil (eg Cialis®) ≤ 48 hours				
Management of associated emergency: Contact MO/NP. See Anaphylaxis, p. 82 1,2,5,6				

3. Clinical assessment^{1,2}

- MO/NP may advise (depending on severity):
 - ECG + continuous cardiac monitoring
 - listen to chest for air entry, crackles or wheeze
 - IVC + bloods/i-STAT - CHEM20, VBG, troponin, FBC
 - urinalysis (protein, blood) + urine microscopy
 - chest x-ray

4. Management

- Continue to manage according to clinical condition involved, as guided by MO/NP
- If acute pulmonary oedema, also see [APO, p. 113](#)
- If discharged, support patient to take oral antihypertensive medicine(s) correctly

5. Follow up

- As guided by MO/NP

6. Referral/consultation

- As above

Arrhythmias - adult

Recommend¹

- Anyone who presents with an arrhythmia should be investigated for cause
- Opportunistically screen patients aged ≥ 65 for atrial fibrillation (AF) by pulse palpation and do ECG if irregular
- ECG flash is available in some Qld remote facilities https://qheps.health.qld.gov.au/__data/assets/pdf_file/0024/2435271/ecg-flash-clinical-guideline.pdf

Background

- Sinus tachycardia (↑ HR with normal ECG) can occur secondary to most injuries and illnesses eg anxiety, fever, infection, blood loss/shock, dehydration

1. May present with²

- Fast, slow or irregular pulse
- \pm symptoms eg:
 - palpitations, sensation of ‘missed beats’
 - SOB, fatigue, dizziness, light-headedness, syncope/fainting, non-accidental falls
 - chest pain/discomfort, hypotension/shock

2. Immediate management²

- **DRSABCD**
- If needed see [BLS, p. 46](#) and [ALS, p. 48](#)
- If chest pain go to [Chest pain assessment, p. 103](#) and [ACS, p. 107](#)
- Vital signs
- ECG³ - **to be reviewed by MO/NP promptly - within 10 minutes if symptomatic**
 - if difficult to interpret, MO/NP may send to cardiologist using [ECG Flash](#) if available. See <https://qheps.health.qld.gov.au/caru/networks/cardiac/ecg-flash>
- Attach cardiac monitor
- Give O₂ if needed to maintain SpO₂ $\geq 94\%$
- Insert IVC x 2
- Take bloods:
 - i-STAT - FBC, UE, troponin, TSH \pm VBG³
 - ASOT in Aboriginal and Torres Strait Islander people/other groups at high risk of [ARF, p. 515](#)

If unstable/deteriorating urgently consult MO/NP² for urgent evacuation +

- Look for reversible causes eg ACS, AF, hypothermia, hypovolaemic shock, electrolyte abnormalities, hypoxaemia, infection, acidosis, hypothyroidism
- **If tachyarrhythmia** - MO/NP will advise management

- **If bradyarrhythmia** - MO/NP will advise. May include:³
 - check if taking beta blockers, calcium channel blocker (diltiazem or verapamil) or digoxin (drug toxicity)³
 - medication (depending on cause) eg:³
 - atropine (for vasovagal bradycardia), or
 - isoprenaline (if available), or
 - other medication(s) if drug toxicity
 - external cardiac pacing if deteriorates/haemodynamically unstable - as per local policy

3. Clinical assessment^{2,3}

- Get rapid history, including:³
 - onset, associated symptoms
 - frequency, timing, duration, severity, longevity, circumstances, triggers, alleviating factors
 - relationship of symptoms to - medications, meals, emotional distress, exertion, positional changes, triggers (eg urination, defecation, cough, prolonged standing, shaving, tight collar, head turning)
 - previous episode(s)
 - medications
 - recent drug/alcohol use
 - cardiovascular disease, renal disease
 - risk factors for cardiovascular disease eg hypertension, diabetes, hyperlipidaemia, smoking, family history
- Listen to the chest for air entry + added sounds - crackles or wheeze
- Any oedema - check legs/ankles + if able sacrum (with patient sitting up and forward)

4. Management

- Consult MO/NP for all arrhythmias, who may advise:
 - further investigation and management of any underlying cause
 - referral to cardiologist
 - evacuation/hospitalisation if required

5. Follow up

- If patient not evacuated/hospitalised advise to be reviewed at next MO/NP clinic, or sooner if indicated

6. Referral/consultation

- Consult MO/NP as above

HMP Electrocution/electric shock - adult/child

1. May present with¹

- Electrical exposure
- Lightning strike
- Trauma, burns
- Cardiac arrest
- Conducted energy weapons eg Taser® - negligible risk of injury in healthy person

2. Immediate management¹

- **Call 000 immediately** and provide Situation Report if patient unconscious or still in contact with electrical source

Do NOT approach patient until SAFE

High voltage from powerlines, train lines, industrial generators - HIGH DANGER

- Voltage from several 1,000 V to 200,000 V possible
- High danger for rescuers to get electrocuted - without perceiving they are close to the source
- **Stay away at a safe distance** - at least 1 m per 10,000 V or as directed by emergency services:
 - high voltage can cause instant death if a flash/arcing occurs
 - electricity can travel through wet ground or air for many metres
- Call the electricity provider/railway company. If unknown call 000 to get support
- **Do not get closer until disconnection of power is confirmed** and the line is grounded on both sides (high voltage electrician, fire and rescue or SES can provide this, **not healthcare providers**)

Household electricity

- Electrical source **must be turned off and protected against it being switched on again**:
 - ensure person or lock is at the fuse box where electricity has been switched off OR power plug pulled and loose end taken with the rescuer
- If not possible, ask for support to remove electrical cables from the patient using dry timber or rubber (non conducting). This task is risky and **should ideally be performed by an electrician, fire and rescue person or SES - not healthcare providers**

- **DRSCABCD** as per [Traumatic injuries, p. 134](#)
- **If in cardiac arrest** see [BLS, p. 46](#). Do prolonged CPR - high likelihood of recovery
- **Do:**
 - vital signs + continuous cardiac monitoring
 - ECG
 - insert IVC
- **If hypotensive** - suspect internal injury:
 - give fluid bolus of sodium chloride 0.9% or Hartmann's 10–20 mL/kg
 - repeat as advised by MO/NP
- **Urgently consult MO/NP for all electrocutions**

3. Clinical assessment¹

- **Ask patient/witness:**
 - type of electrical exposure + voltage if known
 - other circumstances of injury eg fall, in water
 - loss of consciousness or seizures
- **Head to toe assessment** as per **EFGHIJ** in [Traumatic injuries, p. 134](#)
- Look for entry and exit wound
- Urinalysis - check for blood

4. Management¹

- MO/NP will guide management
- Evacuation if:
 - high voltage exposure
 - loss of consciousness, seizures or any other symptoms
 - entry and exit wound present - **suspect serious deep tissue injury** even if looks minor
 - severe pain/tenderness over limb - monitor closely for [Compartment syndrome, p. 160](#)
 - numbness or palsy - indicates critical injury
 - visual disturbance - indicates eye injury
 - trauma/injury/burns
- Treat injuries or [Burns, p. 177](#) as needed
- Offer analgesia. See [Acute pain, p. 32](#)
- If patient has pacemaker or implantable defibrillator, will need function checking:
 - continuous cardiac monitoring required - as soon as available
- MO/NP may allow home after observation if:
 - low voltage exposure
 - asymptomatic
 - no loss of consciousness, seizures or cardiac arrhythmia
 - ECG, urinalysis normal

5. Follow up

- If not evacuated advise to see MO/NP at next clinic

6. Referral/consultation

- Consult MO/NP on all occasions
- Ophthalmology referral as risk of delayed ocular complications¹

HMP Acute lower leg ischaemia - adult

Background^{1,2}

- Caused by a sudden blockage of blood supply to limb needing urgent evaluation + management

Related topics

[Compartment syndrome, p. 160](#)

[DVT, p. 124](#)

1. May present with^{1,2}

- Sudden onset intense pain in 1 leg ±
 - limb is pale, no pulse, pins and needles/paralysis, cold

2. Immediate management¹

- **Contact MO/NP urgently + urgent evacuation** - a longer transfer time = higher risk of limb loss
- Get rapid history, including:
 - leg + any other symptoms
 - past medical history - allergies, current medicines, including recent anticoagulants, antiplatelets or thrombolytic agents eg warfarin, aspirin, clopidogrel³
 - prior thromboembolic events, active bleeding, ↑ risk of bleeding/bleeding disorders eg haemophilia³
- Do vital signs + ECG² + weight
- Offer analgesia. See [Acute pain, p. 32](#)
- Assess limb - neurovascular observations⁴ - compare to other leg:
 - pain, sensation, movement, pulses, capillary refill, warmth, colour, swelling
- Insert IVC + take bloods for baseline APTT (not on i-STAT), FBC

3. Clinical assessment

- As above

4. Management

- MO/NP will consult vascular surgeon for advice, which may include IV heparin bolus ± infusion
- **Note:** heparin is a **high risk medicine** and APTT has to be monitored (baseline + 4–6 hourly):
 - if APTT not able to be done on-site DO NOT give infusion or only start immediately prior to evacuation⁵
 - if evacuation likely to be > 6 hours, a stat dose of enoxaparin (Clexane®)(1 mg/kg) may be considered in lieu of IV heparin⁶
 - use local heparin protocol/heparin order form for doses eg for Qld Health³ <https://qheps.health.qld.gov.au/medicines/medication-safety/forms-charts> (Qld Health intranet only)
- Monitor vital signs + neurovascular observations until evacuated
- Protect limb. Use cage and heel pad if available - **do not elevate**¹

5. Follow up

- As advised by MO/NP

6. Referral/consultation

- As above

HMP Deep vein thrombosis (DVT) - adult

Background¹

- DVT is a blood clot in the deep vein of the leg or pelvis. If not detected and treated can lead to a life-threatening pulmonary embolism

1. May present with¹

- Calf swelling
- Pain/tenderness in one leg
- Distension of surface veins over foot and leg

2. Immediate management¹

- **If DVT suspected** contact MO/NP urgently +
 - in collaboration with MO/NP assess using **Wells score if DVT suspected** below

Wells score if DVT suspected ¹			
Active cancer - treated within ≤ 6 months, or palliative	1	Calf swollen ≥ 3 cm more than the other leg	1
Paralysis, muscle weakness or recent plaster to immobilise lower leg	1	Pitting oedema of the leg	1
Recently bed ridden for ≥ 3 days, or major surgery within 3 months	1	Superficial veins in same leg standing out (not varicose veins)	1
Entire leg swollen	1	Previous DVT	1
Tenderness along distribution of deep venous system	1	Could patient have an alternative diagnosis at least as likely as DVT	- 2
			Score

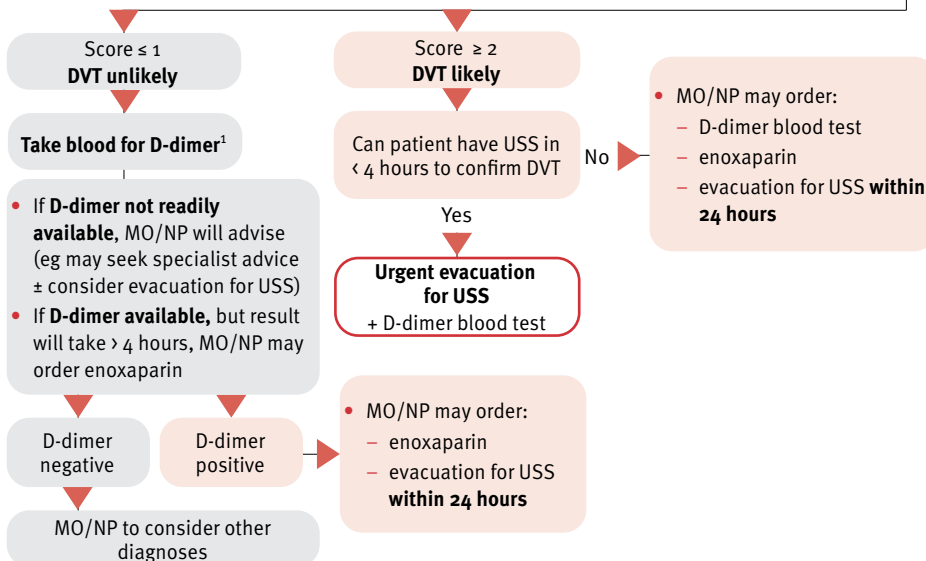

Note: D-dimer not currently available on point of care testing in Qld. Specimen needs freezing if not processed within 4 hours

3. Clinical assessment

- Ask about leg symptoms + past history:¹
 - onset of pain, severity, associated symptoms eg fever
 - pregnant or postpartum, oestrogen therapy
- Do physical examination including:
 - vital signs
 - pregnancy test if female of reproductive age²

4. Management¹

- MO/NP may advise:
 - enoxaparin
 - take blood first - FBC, coagulation studies, CHEM20¹⁻³
 - urgent evacuation as needed
- Offer analgesia. See [Acute pain, p. 32](#)

S ₄	Enoxaparin (Clexane®)			Extended authority ATSIHP/IHW/IPAP
ATSIHP, IHW, IPAP, MID, RIPRN and RN must consult MO/NP				
Form	Strength	Route	Dose	Duration
Prefilled syringe	Various as available	Subcut Do not expel air bubble	1–1.5 mg/kg	stat
Offer CMI: May cause bleeding, bruising and pain at injection site				
Note: Inject into abdomen while patient lying down. Do not rub injection site				
Contraindication: Use with caution if severe hepatic or renal impairment (heparin preferred). Active bleeding, bleeding disorders				
Management of associated emergency: Consult MO/NP. See Anaphylaxis, p. 82				1,4,5

5. Follow up

- As advised by MO/NP

6. Referral/consultation

- As above

HMP Pulmonary embolism (PE) - adult

Background¹

- PE is a life-threatening blood clot in the lung

1. May present with²

- Acute onset SOB
- Hypotension, ↑ HR, ↑ RR, ↓ SpO₂
- Chest pain - sharp/pleuritic, usually one sided ±
 - signs of [DVT, p. 124](#)
 - coughing up blood
 - shock, collapse (massive PE)

2. Immediate management

- **May have massive PE** if sBP < 90, tachy/bradycardia, RR > 20, SpO₂ < 94% (< 88 if COPD)³
 - send for help
 - **contact MO/NP urgently + urgent evacuation**
 - insert IVC x 2
 - MO/NP may seek specialist advice ± order IV bolus tenecteplase.³ See drug box in [ACS, p. 107](#) for doses
 - CPR as needed. See [BLS, p. 46](#)

3. Clinical assessment¹

- Do [Chest pain assessment, p. 103](#)
- Ask about risk factors:
 - cancer, recent surgery or hospitalisation, current/prior DVT, pregnant, 6 weeks postpartum, recent immobilisation, oestrogen use eg contraceptive pill
- Do vital signs:
 - give O₂ if SpO₂ < 94% or 88% if COPD
- Pregnancy test if female of reproductive age²
- ECG within 10 minutes + continuous cardiac monitoring
- **Contact MO/NP urgently**
- If NO signs of massive PE:
 - in collaboration with MO/NP assess likelihood of PE using **Wells score for PE** below

Wells score for PE ¹			
Signs/symptoms of DVT, p. 124	1	Coughing up blood	1
Immobility or surgery in prior 4 weeks	1	Alternative diagnosis less likely than PE	1
Previous DVT or PE	1	Cancer	1
HR > 100	1		Score

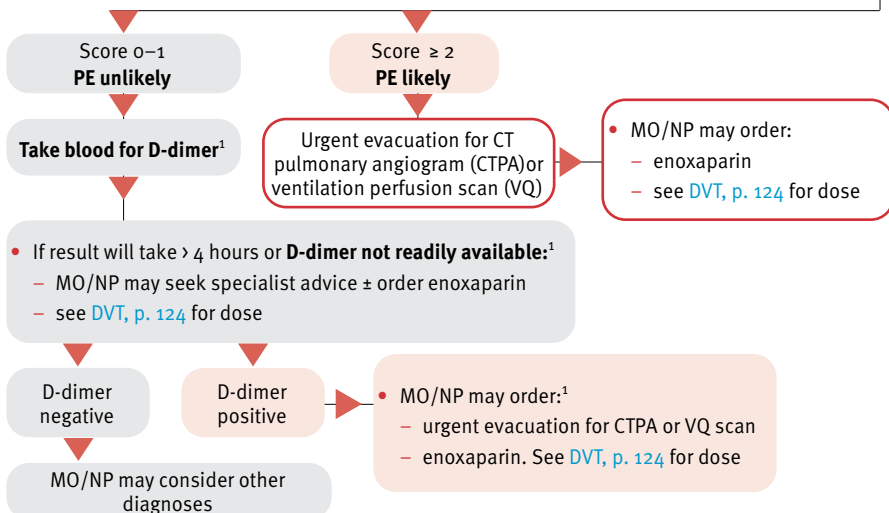

4. Management

- Continue management as per MO/NP
- If enoxaparin ordered:
 - take blood first - FBC, coagulation studies, CHEM20¹⁻³
- Offer analgesia. See [Acute pain, p. 32](#)
- Closely monitor vital signs until evacuated

5. Follow up

- As advised by MO/NP

6. Referral/consultation

- As above

Neurological emergencies

HMP Headache - adult/child

Recommend¹

- Aim to identify red flags of serious causes of headaches
- Also see *Headache - emergency management in children* <https://www.childrens.health.qld.gov.au/qpec-statewide-guidelines/>

Related topics

[Meningitis, p. 72](#)

[Fitting, p. 86](#)

1. May present with¹

- Headache

2. Immediate management¹

- Consult MO/NP urgently if any of:
 - **sudden onset severe headache** - ‘thunderclap headache’ or ‘worst headache of life’:
 - suspect subarachnoid haemorrhage
 - **confusion, drowsiness or neurological changes**
 - **severe ⚡ BP**. Also see [Hypertensive emergency, p. 116](#)
- MO/NP may advise:
 - urgent evacuation
 - insert IVC
 - analgesia
 - closely monitor:
 - vital signs
 - conscious level. See [GCS/AVPU, p. 562](#)
 - neurological observations

3. Clinical assessment¹⁻³

- Get history of headache:
 - pain - nature, intensity, impact on normal activities
 - is this a 'typical' headache
 - onset - when, sudden/slow
 - provoking factors eg exercise, cough, sneeze, sexual activity
 - exacerbating factors eg erect position, exertion/valsalva, worse in mornings, food eg caffeine
 - other symptoms:
 - fever, vomiting
 - aura, visual symptoms, photophobia
 - neck pain, facial pain/tenderness
 - recent:
 - head trauma
 - travel
 - infection in neck or head area
 - sun/heat exposure
 - pregnant or recently postnatal
 - drug/alcohol use
- Past medical history:
 - recent medication change
 - immunocompromised, cancer
 - hypertension
- Do physical examination, including:
 - vital signs
 - [GCS, p. 562](#)
 - check for [Neck stiffness, p. 74](#)
 - [Hydration assessment - adult, p. 200](#) or [child, p. 535](#)
 - pregnancy test if female of reproductive age
- Assess for ANY red flags

Red flags^{2,3}

- Sudden onset reaching maximum intensity within 5 minutes
- Worsening headache with fever
- Rash, neck stiffness or other signs of systemic illness
- New onset neurological signs or personality change
- Confusion or drowsiness/altered LOC
- Head trauma in previous 3 months
- Frequency/severity increases over weeks to months
- HIV, cancer or is immunocompromised
- Triggered by - cough, exercise, valsalva, sneeze or posture change eg lying down
- Vomiting without obvious cause
- > 50 years
- Headache causing night waking, or early morning headache ± vomiting

4. Management^{1,3}

- Consult MO/NP promptly if:
 - any red flags
 - headache is atypical or not ‘usual’ for patient
 - persistent headache, despite treatment with oral analgesia
- If pregnant assess for [Preeclampsia, p. 386](#)

Migraine^{2,4}

- If child consult MO/NP
- If adult says headache is typical of a migraine (that they have previously had) offer:
 - ibuprofen with paracetamol (avoid opioids). See [Acute pain, p. 32](#)
 - AND metoclopramide - even if not nauseous as improves absorption of analgesia. See [Nausea and vomiting, p. 40](#)
- Consider:
 - cold packs over forehead and back of skull
 - hot packs to neck and shoulders
 - neck stretches
 - rest in a dark room
 - **Lifestyle habits**

Tension type headache^{2,5}

- Usually bilateral, feels like pressure or tightness in head, mild to moderate intensity (not severe enough to prevent walking or climbing stairs), ± photophobia, sensitivity to noise, not usually nauseous:
 - offer ibuprofen ± paracetamol. See [Acute pain, p. 32](#)
 - consider advice on **Lifestyle habits**

Lifestyle habits - to help prevent migraines and tension type headaches^{4,5}

- Regular sleep schedule
- Minimise variations in BGL eg eat regular meals, avoid excess sugary food/drinks
- Stay hydrated eg drink 1.5–2 L of water/day
- Limit caffeinated drinks to 1–2 cups/day
- Regular exercise
- Use relaxation techniques to manage stress eg mindfulness, yoga, breathing techniques
- Avoid known triggers for patient eg alcohol, citrus fruit, chocolate, preserved meats, perfume
- If posture problems or neck muscle tightness, refer to a physiotherapist

5. Follow up

- If not evacuated, advise to return if headache does not improve or if concerned

6. Referral/consultation

- Consult MO/NP as above

Transient ischaemic attack (TIA) and stroke - adult/child

Recommend

- TIA + stroke are medical emergencies. Urgent evacuation + timing of treatment is critical¹
- Advise community about FAST stroke recognition message:²
 - Facial weakness, **A**rm ± leg weakness, **S**peech difficulty, **T**ime to act fast

Background

- A stroke occurs when the arteries to the brain become blocked (ischaemic stroke/cerebral infarction) or rupture (haemorrhagic stroke), disrupting blood supply leading to brain damage¹
- TIA - transient episode of neurological dysfunction, most are brief eg < 1 hour + resolve in 24 hours with no brain infarction^{1,3}
- See *Transient ischaemic attack (TIA)/stroke clinical pathway* <https://clinicalexcellence.qld.gov.au/resources/clinical-pathways/tia-stroke-clinical-pathways> (Qld)

1. May present with^{1,3}

- Suspect stroke if abrupt onset of ≥ 1 of:
 - asymmetric:
 - face weakness
 - arm weakness
 - leg weakness
 - speech disturbance eg slurred speech
 - visual field defect/vision loss
- **Note:** any abrupt change in neurological function could represent stroke

2. Immediate management

- **DRSABCD**
- Do BGL - if < 3.5 contact MO/NP urgently + treat as per MO/NP^{1,3}
- **If persistent symptoms for < 9 hours - patient may be thrombolysis candidate - avoid delays²**
- Get rapid history, including:³
 - symptoms + time of onset. If unknown, the last time the patient was seen to be well
 - are symptoms resolving or persisting
 - current medicines eg anticoagulant/antiplatelet medications
 - any seizures, loss of consciousness or syncope
- Suspect TIA if symptoms have resolved. Ask about duration:¹
 - < 10 minutes, 10 minutes–1 hour or > 1 hour
- **Contact MO/NP urgently in all cases of suspected stroke/TIA + urgent evacuation**
- Do vital signs + GCS, p. 562
- **Only give O₂ if SpO₂ < 92%^{1,4}**
- ECG only if does not cause delay. If new atrial fibrillation, send copy of ECG with patient
- Continuous cardiac monitoring
- Insert IVC x 2
- Take bloods - FBC, UE, LFT, coagulation studies, group and hold for x-match

3. Clinical assessment

- Get past history + any TIA/stroke or similar symptoms³
- Do physical examination + weight (if possible)³

4. Management

- **Ongoing management as per MO/NP**
- Brain imaging eg CT scan/MRI required to determine cause^{1,3}
- Check ability to swallow before giving oral medications:
 - if difficulty swallowing - keep nil by mouth
- Give paracetamol if fever
- **If ischaemic stroke:**¹
 - cautious ↓↓ BP if markedly raised eg > 220/110. **Note:** most instances resolve spontaneously
 - do not give aspirin until brain imaging excludes intracranial haemorrhage
 - monitor BGL - avoid aggressive management/IV fluids with glucose
- **If haemorrhagic stroke:**¹
 - urgent reduction of BP may be necessary to ↓↓ haematoma expansion
- **If TIA** - management is similar to ischaemic stroke¹
- Monitor closely until evacuation:
 - vital signs + GCS

5. Follow up

- As per MO/NP

6. Referral/consultation

- As above

HMP Delirium - adult

Recommend¹

- Consider delirium where a patient has one or more of the following risks:
 - age ≥ 45 years for Aboriginal and Torres Strait Islander people
 - age ≥ 65 years
 - history of cognitive impairment or dementia
 - severe medical illness
 - current hip fracture
 - cognitive concerns raised by others

Background¹

- Delirium may be confused with dementia
- Medicine toxicity is a major cause of delirium

1. May present with^{2,3}

- Acute change in mental status
- Difficulty focusing or keeping track, easily distracted

- Behaviour fluctuates in severity over 24 hour period:
 - hyperactive:
 - disorganised or incoherent thinking, rambling or illogical flow of conversation
 - hyperalert, startles easily
 - restlessness, picking at clothes, tapping fingers or making frequent sudden changes of position
 - hypoactive:
 - lethargic, drowsy
 - difficult or unable to rouse
 - disoriented, unsure of where they are or what time it is
 - inability to recall events or instructions
 - sluggishness, staring into space, staying in one position for a long time or moving very slowly
 - disturbance of sleep-wake cycle, excessive daytime sleepiness and insomnia at night
- Hallucinations, illusions or misinterpretations
- Withdrawal states eg tremors, sweating, visual hallucinations
- Fever

2. Immediate management

- If patient is highly agitated, threatening, aggressive or violent, see [Mental health emergency, p. 336](#)
- Screen for [Sepsis, p. 64](#)
- Do not leave patient alone

3. Clinical assessment^{2,4}

- Assess and manage patient in quiet environment
- Ask family or carer about recent behavioural change eg:
 - confusion
 - concentration
 - agitation, restlessness
 - sleepiness, levels of consciousness
 - communication or response levels
 - difficulty meeting requests
 - alterations in mood
- Do full head to toe physical examination
- Identify underlying acute medical causes:^{2,4}
 - infections eg meningitis, encephalitis, neurosyphilis, UTI, pneumonia
 - CNS conditions eg brain lesions or tumours, subdural haematoma, TIA, stroke
 - sodium, potassium and calcium abnormalities. Consider renal or liver disease
 - [Hypoglycaemia, p. 91](#) or hyperglycaemia
 - respiratory disorders leading to hypoxia or pulmonary embolism
 - myocardial infarction, arrhythmias, heart failure
 - seizures, epilepsy and postictal states
 - pain or discomfort eg urinary retention, constipation, hip fracture, dental
 - withdrawal eg alcohol, benzodiazepines
- Urgently identify possible medicines toxicity:^{2,4}
 - consider polypharmacy, particularly drugs with anticholinergic effects, given at high or prolonged doses:

- **anticholinergics**
 - sedating antihistamines eg promethazine, doxylamine
 - drugs for bladder overactivity eg oxybutynin
 - **psychotropics**
 - antipsychotics eg clozapine, olanzapine
 - lithium
 - hypnotics eg benzodiazepines
 - tricyclic antidepressants eg amitriptyline
 - **drugs for parkinsonism**
 - anticholinergics eg benztropine
 - dopamine agonists eg levodopa
 - **cardiac medications**
 - betablockers eg sotalol and propranolol
 - digoxin
 - **analgesics**
 - opioids
 - tramadol
 - nonsteroidal anti-inflammatory drugs (NSAIDs)
 - **antiemetics**
 - prochlorperazine
 - hyoscine hydrobromide
 - **corticosteroids (high dose)**
 - **alcohol and illicit drugs** eg cannabis, methamphetamine
- Do vital signs +
 - SpO₂ and BGL to exclude hypoxia or hypoglycaemia as a cause
 - Do:
 - bloods/i-STAT - BGL, FBC, UE, LFT
 - urinalysis and MSU for MCS
 - ECG
 - drug screen:
 - therapeutic drug monitoring if taking digoxin, lithium, quinidine
 - illicit drugs
 - chest x-ray

4. Management^{2,4}

- **Manage and treat underlying medical cause as above in consultation with MO/NP**
- For suspected medicines or other substance use, see [Poisoning and overdose, p. 211](#)
- Contact pharmacist for medication review
- Offer analgesia. See [Acute pain, p. 32](#)
- Address hydration, nutrition, ventilation, temperature control, skin care, bladder and bowel care
- Provide familiar environmental cues ie clocks, calendars, with involvement from family
- Commence regular observations. Observe at all times

5. Follow up

- As per MO/NP or specialist instructions
- According to identified cause of delirium

6. Referral/consultation

- Consult MO/NP and specialist

Traumatic injuries

HMP Traumatic injuries - adult/child

Recommend¹

- **Early notification for transfer.** See [Criteria for early notification of trauma for interfacility transfer \(inside front cover\)](#), or if outside Qld, follow local policy
- Assume possible spinal injury in all blunt trauma or multiple injuries. Use caution when moving¹
- Systematic evaluation of all trauma patients (minor and major)²

Background

- Common causes of preventable death in trauma: airway obstruction, tension pneumothorax and haemorrhage
- Hard/semi-rigid cervical collars are not recommended^{3,4}

1. May present with

- Trauma

2. Immediate management. Primary survey and resuscitation DRSCABCD^{1,6-9}

Danger - eg body fluids, toxins, traffic, perpetrators of crime, < 10 m from fallen [powerlines](#), p. 121

- If there is immediate threat to a person's life and rapid movement is needed, make all efforts to limit spinal movement without delaying treatment.¹⁰ If you are by yourself and patient needs moving out of danger, you may need to drag them via ankle or arm/shoulder³

Response

Send for help - ideally 1 or more assistants are needed

Catastrophic haemorrhage - control before checking airway^{1,2,7,8}

- Do not remove any penetrating/impaled objects eg knife¹⁰
- Use **direct firm pressure** - with hands + combine pads and crepe bandages. If not working, check pad(s) is over bleeding point/using firmer pressure with 1 or 2 pads over smaller area
- If unable to control:
 - use **haemostatic dressing** - hold against bleeding point, then bandage¹⁰
 - or **arterial tourniquet** (if limb):^{6,10}
 - apply firmly 5 cm above the injury/amputation (not over a joint/wound)
 - tighten until bleeding stops - if not stopping, try 2nd tourniquet above the 1st¹¹
 - record application time + tell retrieval team. Do not cover with bandage/clothing

Airway and cervical spine (c-spine)^{1,3,4,7,9}

- Look - signs of airway obstruction eg use of accessory muscles¹
- Listen - upper airway noises + breath sounds - absent, diminished, noisy (snoring, gurgling, stridor)
- Open airway - chin lift/jaw thrust ±
 - airway adjuncts eg oro/nasopharyngeal (not if base of skull fracture), [LMA](#), p. 56
 - suction/remove loose foreign bodies eg blood, vomit, oedema, loose teeth/foreign objects
- **Maintain c-spine stabilisation:**^{3,4,9}
 - support head in a neutral position in line with torso - avoid twisting/angular movements
 - consider soft collar ± sand bags to support neck

- If needed, roll a 'face-down' non-responsive person onto their back to assess airway⁵
 - if excessive bleeding into the airway that suction cannot remove, roll onto side¹
- Check for wounds/injury
- If motorbike helmet⁵ - remove while assistant restricts movement of c-spine⁷

Breathing^{1,6-9}

- Fully expose chest. Assess:
 - RR, effort, open wounds, bruising, deformity
 - circumferential or airway burn ie singed facial hair, soot in mouth/nose
 - use of accessory muscles, symmetrical/paradoxical chest movements
 - auscultate for breath sounds/air entry (listen in axilla area)¹
- If tension pneumothorax - do immediate [Needle decompression, p. 141](#) with 14 G needle^{7,9}

Signs of tension pneumothorax - life-threatening

- Decreased/absent breath sounds
- Hyper-resonance on percussion
- ↑ HR, ↓ BP, ↑ SOB
- Distended neck veins

- If open/sucking chest wound - apply occlusive [3 sided dressing, p. 141](#)/vented chest seal
- If any abnormalities, see [Chest injuries, p. 140](#) for possible causes + immediate management
- Give O₂ to maintain SpO₂ ≥ 94%
- Start bag-valve mask ventilation if indicated

Circulation + haemorrhage control⁷⁻⁹

- Control external haemorrhage by direct pressure/bandaging ± elevate + reassess tourniquet application
- HR, central capillary refill time
- Insert IVC x 2 large bore OR [Intraosseous, p. 57](#)
- **If shock** (cool, ↑ HR, capillary refill > 2 seconds):^{7,10}
 - IV fluid bolus (warmed if possible) - sodium chloride 0.9% or Hartmann's:
 - **adult** 1 L (250 mL increments, aim to maintain sBP at 90). **Child** 10–20 mL/kg
 - try to find source of haemorrhage eg chest, abdomen, pelvis, long bones

Disability - basic neurological evaluation^{1,6-9}

- Alert, Voice, Pain, Unresponsive
- BGL
- Pupils - size, equal + reacting

3. Clinical assessment. Secondary survey - EFGHIJ

- Start only after lifesaving interventions/management have been initiated
- If ongoing bleeding/life-threatening injury - consult MO/NP urgently

Exposure, Environment, Early transfer notification^{1,7,9}

- Assess using [Criteria for early notification of trauma for interfacility transfer, \(inside front cover\)](#)
- Remove all clothing
- Keep warm/prevent hypothermia - cover with blanket/space blanket

Full vital signs, eFAST, Family

- Vital signs + neurological observations - [GCS, p. 562](#), motor response in limbs, fontanelle in infant
- Consider eFAST if trained/available^{1,6,7,9}
- Communicate with/support family/friends

Give pain relief. Get resuscitation adjuncts⁵

- Lab/bloods - FBC, UE, lactate, troponin, BGL, LFT, group and hold, coagulation studies, blood gases ± blood alcohol/toxin screen^{1,9}
- Monitor vital signs at least 15 minutely. Attach cardiac monitor + ECG
- Naso/orogastric tube (consider) - not NG if suspect base of skull fracture^{1,9}
- Oxygen/capnography as indicated¹²
- Pain - assess + analgesia eg morphine or fentanyl.^{7,9} See [Acute pain, p. 32](#)
 - if head injury suspected, do not give opioid until discussion with MO/NP

History from patient/witnesses^{1,7,9}

- Allergies + check for medic alert eg jewellery, key ring, USB stick, shoe tag, anklet, watch, tattoo
- Medications + anticoagulation/antiplatelet therapy
- Past medical history + bleeding disorder, [Tetanus immunisation, p. 557](#)
 - last menstrual period, possible pregnancy
- Last meal
- Events related to injury:⁵
 - mechanism:
 - **blunt** - speed of patient/objects, seatbelt use, air bag deployment, direction of impact, damage to car/bike, distance ejected from vehicle, height of fall/body part landed on
 - **penetrating** - type of firearm/distance from, number of shots, type/length of blade
 - any loss of consciousness + duration
 - amnesia
 - alcohol/drug use
 - social issues eg domestic and family violence

Head to toe assessment - search everywhere for injuries as per table below^{1,5,7,9}

CHECK for - pain, deformities, bruising, swelling, lacerations, abrasions, burns, impaled object(s) eg knife (do NOT remove impaled objects)	
General appearance	<ul style="list-style-type: none"> • Position found, posture, guarding/self-protection movements • Odours - alcohol, petrol, chemicals, vomit, urine, faeces
Head and face^{1,7}	<ul style="list-style-type: none"> • Inspect face and scalp for lacerations/bruising/penetrating injury + check: <ul style="list-style-type: none"> – eyes - size, equal + reacting, foreign body/contact lenses, subconjunctival haemorrhage, hyphaema, irregular iris, penetrating injury – movements - ask to follow your moving finger in all directions – also see Eye injury, p. 286 – nose - deformity, CSF leak, bleeding, look in nose - any asymmetry of septum ± bluish/reddish swelling (may be septal haematoma). Also see epistaxis, p. 190 – mouth - lacerations to gums, lips, tongue, palate. Check if any missing/loose/broken teeth.¹ Bite malocclusion - may be Fractured jaw, p. 157 – ears - bleeding, blood behind eardrum, CSF leak - do NOT pack to stop drainage • Bruising behind ears ('Battle sign') or periorbital (raccoon's eyes) = base of skull fracture • Palpate - skull, orbit, nose and jaw, noting: <ul style="list-style-type: none"> – depression(s) in skull, boggy swelling of scalp, bony tenderness, subcutaneous emphysema[#], fontanelle in baby⁹ • If ANY trauma to head, see Head injuries, p. 143 • Scalp lacerations can result in major blood loss⁷ - close with staples or sutures prior to transfer if able (or tie hair to close) as per Acute wounds, p. 162

Neck ^{1,6,7}	<ul style="list-style-type: none"> • Palpate neck while maintaining in-line immobilisation of the c-spine eg head and neck immobilised with 2 hands by assistant. Check if: <ul style="list-style-type: none"> – pain, deformity – bony/laryngeal tenderness or crepitus/step, subcutaneous emphysema[#] – veins - distended/flattened¹² • Assume c-spine injury until excluded. See NEXUS tool in Spinal injuries, p. 147
Chest ⁶⁻⁹	<ul style="list-style-type: none"> • Inspect + palpate entire chest wall - including clavicles, sternum, ribs, axilla (do NOT spring rib cage). Check: <ul style="list-style-type: none"> – expansion, paradoxical movement, accessory muscle use – tenderness, crepitus – subcutaneous emphysema[#] • Auscultate + percuss: <ul style="list-style-type: none"> – breath sounds/lack of, wheeze, crackles (listen in axilla area) – heart sounds - murmurs, friction rubs, muffled sounds – hyper-resonance/dullness • If significant chest injury suspected - auscultate BP in both arms and note if difference > 10–15 may indicate aortic injury • If any abnormalities, see Chest injuries, p. 140 • Haemothorax can result in major blood loss
Abdomen and flanks ^{1,6-9}	<ul style="list-style-type: none"> • Inspect for lacerations, seat-belt bruising/red marks • Auscultate bowel sounds - present/absent (before palpating) • Palpate - tenderness, guarding, rigidity, rebound tenderness, masses: <ul style="list-style-type: none"> – especially over liver, spleen, kidneys and bladder¹ • Assess repeatedly - injury may not be obvious. See Abdominal injuries, p. 150
Pelvis ^{1,7}	<ul style="list-style-type: none"> • Gently palpate for tenderness. Do NOT spring pelvis • If fracture suspected apply pelvic binder, p. 156 NOW - even if low suspicion - do not log roll. Once binder in place, only log roll if essential • Fractured pelvis, p. 156 can result in major blood loss⁷
Perineum, genitalia ¹	<ul style="list-style-type: none"> • Inspect for bruising/bleeding • If bleeding from urethral opening/scrotal haematoma - suspect pelvic fracture⁷ • Note priapism (persistent erection) - symptom of spinal injury
Limbs ^{1,7}	<ul style="list-style-type: none"> • Inspect and palpate entire length of limbs: <ul style="list-style-type: none"> – tenderness, deformity, swelling, open fractures – movement of joints and strength/range of motion (passive and active) – colour, distal pulses, warmth, movement, sensation, capillary refill • Apply splint(s) as per Simple fracture of limbs, p. 152 and do neurovascular observations as needed • If discrepancy in leg length or rotational deformity in leg without obvious fracture, suspect Fractured pelvis, p. 156 • Fractured femur and any open long bone fractures can result in major blood loss⁷
Inspect back ¹	<ul style="list-style-type: none"> • log roll, p. 148 if assistance available (may be best achieved at time of transfer) - do not roll onto side with injury • Ask patient to squeeze buttocks if awake • Inspect and palpate - back/chest, flanks, buttocks, perineum and posterior thighs: <ul style="list-style-type: none"> – deformity, bruising, swelling, tenderness/deformity/step (along spine) – subcutaneous emphysema[#] • Auscultate for air entry, abnormal sounds

[#]subcutaneous emphysema - air trapped under the skin (skin crackles when palpating)

Jot it down

- Ensure clear, accurate, concise documentation^{1,7}

4. Management¹

- Continually reassess primary survey + monitor for signs of airway compromise
- Continue c-spine precautions + spinal immobilisation until evacuated:
 - for guidance on **moving trauma patient** see [Spinal injuries, p. 147](#)
- Treat wounds - remove gross contamination/irrigate + cover
- If impaled object eg knife, VERY CAREFULLY pack around with gauze soaked in sodium chloride 0.9% and secure¹⁰
- Splint fractures¹
- MO/NP will advise ongoing management, which may include:^{1,7,9}
 - IV fluids
 - tranexamic acid (within 3 hours) if haemorrhage
 - antibiotics eg if open fracture,⁷ penetrating trauma¹
 - monitor vital signs + neurological observations
 - keep warm/prevent heat loss
 - nil by mouth
 - IDC + urinalysis, monitor urine output hourly
 - x-ray(s)
- Give [Tetanus immunisation, p. 557](#) if indicated
- Also consider [Electrocution, p. 121](#), [Compartment syndrome, p. 160](#), [Burns, p. 177](#)
- If not evacuated but affected by drugs/alcohol:
 - encourage to stay under observation until nonaffected, or if discharged, into the care of a responsible nonaffected adult
- Consider non-accidental injury (if injury/presentation inconsistent with history) eg self inflicted injury, elder abuse, [Domestic and family violence, p. 241](#), + consider [Child protection, p. 551](#)

Pregnant woman with trauma^{7,13}

- Can lose a significant amount of blood before ↑ HR, ↓ BP, signs of shock evident¹³
- If > 20 weeks pregnant (uterus at level of umbilicus):
 - lie on left side, or if spinal precautions/lying on back, tilt the right side 15–30° by placing a wedge under her hip/spinal board
 - **note:** baby can compress the vena cava causing hypotension if lying flat
- Have high index of suspicion for [Abdominal injuries, p. 150](#) even with minor trauma
- Also see Qld Clinical Guideline *Trauma in pregnancy* <https://www.health.qld.gov.au/qcg/publications#maternity>

Amputated body part⁷

- Thoroughly wash with sodium chloride 0.9%, then wrap in moist sterile dressing (eg combine)
- Further wrap in moistened sterile towel
- Place in plastic bag and transport with patient in cooler box eg Esky® with crushed ice
- Do not freeze

S4	Tranexamic acid			Extended authority ATSIHP/IHW
ATSIHP, IHW, RIPRN and RN must consult MO/NP				
Form	Strength	Route	Dose	Duration
Injection	1000 mg/ 10 mL	IV	Adult 1000 mg Dilute in 100 mL sodium chloride 0.9%	stat Infuse over 10 minutes
			Child 15 mg/kg Dilute 10 mL (1000 mg) to 100 mL to give concentration of 10 mg/mL	
Offer CMI: May cause hypotension, dizziness (particularly after rapid administration), thrombosis or visual disturbances				
Contraindication: Active intravascular clotting. Use with caution if subarachnoid haemorrhage or if predisposition to thrombosis. Reduce dose if renal impairment				
Management of associated emergency: Consult MO/NP. See Anaphylaxis, p. 82				14-16

5. Follow up

- Be guided by MO/NP

6. Referral/consultation

- Consult MO/NP as above

HMP Chest injuries - adult/child

Background¹⁻³

- **Life-threatening emergencies** include tension pneumothorax, massive haemothorax, open pneumothorax, flail chest, pulmonary contusions, great vessel injury, diaphragm rupture

1. May present with

- Chest trauma

2. Immediate management¹⁻⁶

- Do primary survey **DRSCABCD** as per [Traumatic injuries, p. 134](#) + initiate any lifesaving measures
- Assess against [Criteria for early notification of trauma for interfacility transfer \(inside front cover\)](#)
- Use tables below for possible chest injuries and for immediate management

Blunt trauma to chest eg fall from height, motor vehicle accident ¹⁻⁴		
Signs and symptoms		Consider
<ul style="list-style-type: none"> • Increasing SOB, ↑ HR, ↓ BP • Agitation, hypoxia • ↓ air entry + hyper-resonance on percussion on affected side • ↓ chest movement • Trachea deviation (late sign) 	Tension pneumothorax	<ul style="list-style-type: none"> • Immediate needle decompression (next page)
<ul style="list-style-type: none"> • ↓ air entry/dull percussion on affected side • Hypotension/shock • Hypoxia 	Haemothorax can be massive	<ul style="list-style-type: none"> • Treat hypovolaemia - IV sodium chloride 0.9% or Hartmann's 1 L (20 mL/kg for child) • If respiratory distress develops, treat as tension pneumothorax
<ul style="list-style-type: none"> • Paradoxical movement - segment of chest wall moves in when the patient breathes in and out when patient breathes out 	Flail chest	<ul style="list-style-type: none"> • Ventilation support as needed • MO/NP may intubate prior to evacuation
<ul style="list-style-type: none"> • Coughing up blood, crackles • ↑ HR, hypoxia, ↑ WOB 	Pulmonary contusion	<ul style="list-style-type: none"> • O₂ + ventilation support
<ul style="list-style-type: none"> • ↓ air entry and ↑ percussion on affected side • ± unequal chest movement 	Simple pneumothorax	<ul style="list-style-type: none"> • Be alert to ↑ SOB - may be tension pneumothorax
<ul style="list-style-type: none"> • Tender sternum 	May have underlying lung or cardiac injury	<ul style="list-style-type: none"> • ECG • MO/NP will advise further
<ul style="list-style-type: none"> • Chest wall tenderness/swelling • Pain worse on inspiration/cough 	Broken rib(s)	<ul style="list-style-type: none"> • MO/NP may advise review next day if minor/no other injury/concerns
<ul style="list-style-type: none"> • ↓ BP, asymmetric, diminished or absent peripheral pulses • Paraplegia 	Great vessel injury³	<ul style="list-style-type: none"> • Urgent MO/NP advice

Penetrating trauma to chest eg gunshot or stab wound^{1,4,5}

Signs and symptoms	Consider
<ul style="list-style-type: none"> Wound to the chest ± object sticking out 	<ul style="list-style-type: none"> Do NOT remove any object sticking out of wound eg knife. VERY CAREFULLY pack around with gauze soaked in sodium chloride 0.9% and secure Cover open chest wound with: <ul style="list-style-type: none"> vented chest seal OR sterile occlusive dressing large enough to overlap the wound edges, taped securely on 3 sides (opening at bottom) to provide a flutter-type valve effect - air can move out but not in
<ul style="list-style-type: none"> Chest wall opening Air sucking in 	

Other life-threatening complications: cardiac tamponade (can be detected with eFAST), aortic/tracheo-bronchial/oesophageal injury, diaphragm injury, blunt cardiac injury^{2,3}

Needle decompression for tension pneumothorax^{5,6}

- Insert 14 G needle/cannula (use longer needle) at **2nd intercostal space, mid-clavicular line**
 - air should escape with a rush + respiratory distress should decrease
- If not working:
 - insert needle at **5th intercostal space, mid axillary line**
 - check IVC has not kinked or tension pneumothorax has recurred/another on the other side
- Note:** will require definitive treatment ie chest drain to be inserted

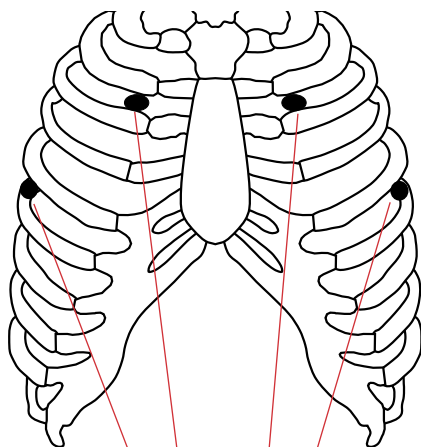

Needle decompression sites

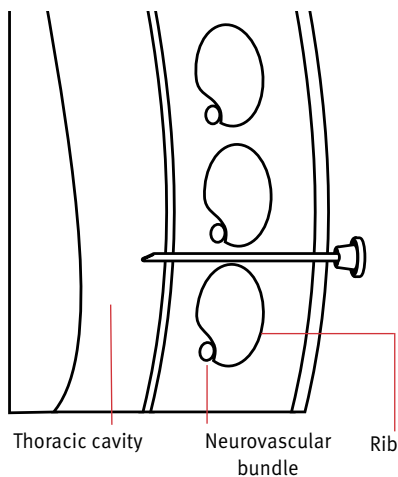

3. Clinical assessment⁶

- Do secondary survey **EFGHIJ** as per [Traumatic injuries, p. 134](#) including **examination of chest**
- Do eFAST if trained/available
- Be aware of risk factors for potential deterioration:²
 - past history - smoker, COPD, asthma, obesity
 - age > 55 years, uncontrolled pain

- respiratory compromise: ↑ WOB, ↑ RR, ↓ SpO₂
- ≥ 3 fractured ribs
- shallow breathing, unable to cough

4. Management^{1,2,6}

- Give O₂ to maintain SpO₂ ≥ 94%
- Ensure **adequate analgesia**.² See [Acute pain, p. 32](#)
- Consult MO/NP in all cases, who may advise:
 - urgent evacuation
 - close monitoring of vital signs + WOB
 - chest x-ray
 - ECG
 - nil by mouth
 - bloods - FBC, group and hold
- **Note:** if critical, MO/NP may advise finger thoracostomy (if skilled). Usually only done if patient ventilated
- MO/NP may insert chest tube prior to evacuation. Attach to Heimlich Valve® or similar ambulatory chest drainage system for evacuation

5. Follow up

- MO/NP will advise ongoing management

6. Referral/consultation

- As above

HMP Head injuries - adult/child

Recommend¹

- Consider the possibility of non-accidental head trauma in all children presenting with mild to moderate head injury
- Do not do x-ray or USS in lieu of CT scan if skull fracture suspected in child

Background

- If child, also see *Head injury - emergency management in children* <https://www.childrens.health.qld.gov.au/qpec-statewide-guidelines>
- Head injury clinical pathways (Qld) <https://clinicalexcellence.qld.gov.au/resources/clinical-pathways/head-injury>

1. May present with

- Trauma to head

2. Immediate management¹⁻⁴

- Do primary survey **DRSCABCD** as per *Traumatic injuries*, p. 134 + initiate any lifesaving measures
- Consider need for **c-spine immobilisation**, p. 147
- Assess against **Criteria for early notification of trauma for interfacility transfer (inside front cover)**
- Do **GCS**, p. 562 + neurological observations:⁵
 - pupil size + reaction to light
 - motor response in limbs
 - fontanelle in infant
- Do vital signs + BGL if altered LOC
- **Consult MO/NP urgently if:**^{2,4,6}
 - GCS < 15
 - seizure(s)
 - penetrating injury or suspected skull fracture (depressed/open)
 - basal skull fracture suspected - black eye with no damage around eyes, bleeding from ear(s), clear fluid (CSF) from ear(s) or nose, bruising behind ear(s)^{1,3}
 - focal neurological deficit eg loss of sensation, paraesthesia
 - **signs of ↑ intra cranial pressure (ICP):**²
 - GCS decreasing
 - abnormal posture (decorticate/decerebrate)
 - abnormal pupil responses, pupil dilation (1 or both), upward gaze
 - ↑ BP + ↓ HR + breathing abnormalities - ‘Cushing’s triad’ (late sign)
 - **may be just** headache, vomiting, irritability, altered LOC ± Cushing’s triad

3. Clinical assessment^{2,4}

- Do secondary survey **EFGHIJ** as per *Traumatic injuries*, p. 134, including **examination of head**
- Get history, including:¹⁻³
 - time/date of injury, witnessed or not
 - mechanism of injury/how it happened
 - use of alcohol/drugs
 - bleeding disorder/taking anticoagulants^{1,4}

- Ask about symptoms. Any:¹⁻⁴
 - loss of consciousness - when, how long for. If < 2 years old, was it for ≥ 5 seconds²
 - vomiting (amount), headache (severity)¹
 - seizure(s) or amnesia post injury - when/duration
 - double vision, ataxia, clumsiness, gait abnormality
 - abnormal behaviour (child/infant) eg drowsiness, agitation, restlessness, not interested in things around them, not themselves (as reported by parent)²
 - weakness/tingling in arms or legs
- Assess for **Head injury risk factors** as per tables below

Head injury risk factors - child²		
Low risk	Intermediate risk	High risk
ALL of the following	No high risk features + ≥ 1 of the following MAY need urgent CT scan	≥ 1 of the following Urgent CT scan
<ul style="list-style-type: none"> • Well appearing child • GCS 15 • No intermediate or high risk features present 	<ul style="list-style-type: none"> • Severe headache • Vomiting • Amnesia • Post-traumatic seizure • Altered mental status (drowsiness, agitation, repetitive questioning, slow verbal response) • Significant mechanism of injury, including: <ul style="list-style-type: none"> – fall from significant height (≥ 1 m if aged < 2, or > 1.5 m if ≥ 2 years)¹ – following vehicle accident - high speed, ejected from vehicle or with others significantly injured in crash – pedestrian/cyclist impacted by car – impact from high speed object eg golf ball, ceiling fan 	<ul style="list-style-type: none"> • GCS < 14 • Focal neurological deficit • Clinical suspicion of: <ul style="list-style-type: none"> – basal skull fracture (raccoon eyes, blood behind eardrum, Battle's sign, clear fluid leaking from ear or nose (CSF) – depressed skull fracture (boggy haematoma, palpable depressions) – penetrating injury – open skull fracture – large haematoma, laceration or bulging fontanelle in young child – non-accidental injury – extensive other injuries

Head injury risk factors - adult⁶	
'High risk' any of the following	
<ul style="list-style-type: none"> • Age > 65 years • On anticoagulant/antiplatelet therapy • Known coagulopathy eg liver disease, factor deficiency • Known neurosurgery and/or neurological impairment 	<ul style="list-style-type: none"> • Multi-system trauma • Delayed presentation or re-presentation • Persistent abnormal level of alertness, behaviour and/or cognition • Multiple comorbidities or combination of worrying factors
Urgent CT scan if below⁶	
<ul style="list-style-type: none"> • Dangerous mechanism of injury • Clinical suspicion of skull fracture • Unwitnessed head injury • Loss of consciousness > 5 minutes • Intoxicated (alcohol \pm other drugs) • Persistent vomiting/more than 1 episode³ • Persistent severe headache 	<ul style="list-style-type: none"> • Deterioration in GCS • Focal neurological deficit • Post traumatic seizure • Anterograde or retrograde amnesia > 30 minutes • Persistent GCS < 15 at 2 hours post injury • Skull fracture suspected or other clinical concern

4. Management

- If drug or alcohol intoxicated at presentation, treat as if the neurological findings are due to the head injury until proven otherwise^{1,3,4}
- If scalp laceration, control bleeding - **can result in major blood loss:**⁴
 - easily controlled by closing with staples/sutures/tying hair. See [Acute wounds, p. 162](#)
 - ± combine + pressure bandage

If symptoms/unstable, assessed as high/intermediate risk or fractured skull suspected

- **Urgently consult MO/NP who may advise:**^{2,4,6}
 - urgent evacuation for CT scan
 - monitor closely:
 - GCS + neurological observations
 - vital signs
 - pain and sedation score as needed
 - IVC x 2 or [Intraosseous, p. 57](#)
 - O₂ to maintain SpO₂ ≥ 95% (+ capnography if available)
 - BGL
 - analgesia ± antiemetic - only on MO/NP orders
 - if **ICP**:
 - elevate head of bed 20–30°
 - support airway/ventilation
 - keep warm/avoid hypothermia
 - if seizures, manage as per [Fitting, p. 86](#)
 - MO/NP may consider:
 - IV fluid bolus 10–20 mL/kg sodium chloride 0.9% to avoid hypovolaemia
 - sodium chloride 3% or mannitol^{2,4}
- If GCS ≤ 8, patient is in a coma/has severe injury + will need intubation by MO/NP prior to evacuation.⁴ Consider [LMA, p. 56](#) until intubation possible

If asymptomatic, fully awake and alert, have no neurological abnormalities + assessed as low risk

- If baby < 6 months, consult MO/NP promptly¹
- If child **very low risk** no need to monitor ie:^{1,2}
 - trivial injury (ground level fall, walking/running into stationary objects), no loss of consciousness, GCS 15 AND no signs or symptoms of head trauma other than an abrasion. Discharge with **Head injury advice**
- Otherwise, in collaboration with MO/NP, monitor neurological observations for 4–6 hours:^{2,6}
 - 1/2 hourly for 1st 2 hours post injury, then hourly for 2–6 hours/until discharged
 - if GCS falls ≥ 1 point for 30 minutes,³ symptoms develop/persist, or any abnormal observations, **urgently consult MO/NP**
- Consider discharge ≥ 4–6 hours if:^{1,2,6}
 - GCS remains at 15
 - neurological observations remain normal + no symptoms develop
 - no concerns of non-accidental injury in child
 - no concerns of alternative/concurrent illness
 - patient has responsible adult to observe them for 24 hours + can return promptly if needed
 - not under the influence of drugs or alcohol¹
 - have been given **Head injury advice** + know when to return to clinic^{1,2,4,6}
- Consider a longer period of observation if antiemetics have been given³

Head injury advice - give verbal and written advice⁷⁻⁹

- Adults and children should be observed by someone responsible for next 24 hours
- Give fact sheets eg:
 - **adult** - *Concussion/minor head injury without concussion* <https://clinicalexcellence.qld.gov.au/resources/emergency-department-patient-information-sheets>
 - **child** - *Head injury care after discharge* <https://www.childrens.health.qld.gov.au/chq/information-for-families/fact-sheets/>

General advice

- Rest quietly for next 48 hours
- Eat a healthy diet, drink lots of fluids
- Avoid activities that make symptoms worse
- Use ice packs on swollen or painful areas
- Use paracetamol for headache (not ibuprofen)
- Do not take sedatives/other medicines unless instructed
- Do not drive for at least 24 hours and only once you can concentrate properly
- Return to exercise after a few days rest

Concussion

- Symptoms may include:
 - mild headaches, which settle with rest/paracetamol
 - mild dizziness, feeling tired, difficulty paying attention or remembering things
 - feeling emotional or moody
- Symptoms usually settle over time. Return to clinic if you are worried

Return to the clinic immediately if

- Severe headache, especially if getting worse
- Dizziness or unsteady walking
- Nausea, vomiting or poor feeding (child) or frequent vomiting (adult)
- Unexpected drowsiness or weakness
- Disorientation or confusion
- Restlessness (adult), irritability, continued crying or unusual agitation (child)
- Slurred speech or double/blurred vision
- Seizure (fit) or spasms of face or limbs
- Difficult to wake up
- If you are worried for any reason

5. Follow up

- If not evacuated advise to be reviewed the next day and at the next MO/NP clinic (1–2 weeks)¹
- If on anticoagulants/has bleeding disorder, advise follow up within 72 hours due to increased risk of intracranial haemorrhage⁶

6. Referral/consultation

- Consult MO/NP as above

HMP Spinal injuries - adult/child

Recommend¹

- Focus on minimal handling, maintaining immobilisation and preventing further damage

Background

- Hard/semi-rigid cervical collars are not recommended^{1,2}
- Cervical spine injury is relatively rare in children.^{2,3} Also see *Cervical spine injury - emergency management in children* <https://www.childrens.health.qld.gov.au/qpec-statewide-guidelines/>

1. May present with¹

- History of trauma, in particular:
 - motor vehicle or motor bike accident - occupant, rider or pedestrian
 - industrial accident ie workplace
 - dive or jump into shallow water or being ‘dumped’ in the surf
 - sporting accident eg rugby, falling from a horse, trampoline²
 - fall from greater than standing height eg ladder, roof
 - fall in the elderly
 - significant blow to head
 - severe penetrating wound eg gunshot

2. Immediate management

- Do primary survey **DRSCABCD** as per [Traumatic injuries, p. 134](#) + initiate any lifesaving measures
- **Maintain cervical spine (c-spine) in-line immobilisation:**¹

Cervical spine (c-spine) in-line immobilisation

- Support head in a neutral position in line with torso - avoid twisting/angular movements
- Use soft collar (as prompt to restrict movement) + sand bags to support neck if unconscious^{1,2}
- Padding may help - **adult:** 2 cm under head **child < 8:** use thoracic elevation device (TED)^{1,3}
- If conscious, ask them to stay still¹
- Restrict spinal movement until patient can undergo appropriate examination ± imaging⁴
- Lay flat on firm supportive surface

- Do vital signs + BGL
- Assess against [Criteria for early notification of trauma for interfacility transfer \(inside front cover\)](#)

3. Clinical assessment^{1,4}

- Do secondary survey **EFGHIJ** as per [Traumatic injuries, p. 134](#)
 - note mechanism of injury + check for symptoms of spinal injury eg:¹
 - tingling, numbness in the limbs - where⁶
 - weakness or inability to move the limbs (paralysis)
 - altered/absent sensation - where
 - nausea, headache or dizziness
 - head or neck in abnormal position
 - signs of head injury, altered LOC, shock
 - breathing difficulties - c-spine or thoracic injury can cause respiratory failure
 - change in muscle tone (flaccid/stiff)
 - loss of bladder or bowel control
 - priapism (persistent erection in males)

Use NEXUS criteria to assess risk of c-spine injury

NEXUS Criteria to assess risk of c-spine injury^{4,5}

- | | |
|----------|--|
| 1 | <p>Midline cervical tenderness</p> <ul style="list-style-type: none"> • Neck pain on palpation of the posterior midline neck area, from nuchal ridge to the 3rd thoracic prominence, or palpation of any cervical spinous process |
| 2 | <p>Altered mental status</p> <ul style="list-style-type: none"> • GCS < 15 • Disorientation to time, place, person or event • Inability to remember 3 objects at 5 minutes • Delayed or inappropriate response to external stimuli |
| 3 | <p>Focal neurologic deficit</p> <ul style="list-style-type: none"> • eg motor weakness, numbness/loss of sensation, paraesthesia, other eg priapism⁴ |
| 4 | <p>Intoxicated - any of</p> <ul style="list-style-type: none"> • Patient or observer reports recent history of intoxication/consumption of intoxicating substances • Odour of alcohol, slurred speech, ataxia, lack of coordination, or other cerebellar findings • Behaviour consistent with intoxication • Tests of bodily secretions are positive for drugs or alcohol affecting mental alertness |
| 5 | <p>Painful distracting injury</p> <ul style="list-style-type: none"> • Any non spinal related condition causing sufficient pain to distract patient from a possible cervical spine injury eg: <ul style="list-style-type: none"> – long bone fracture, significant visceral injury – large laceration, crush or degloving injury, large burns – other injury that could impair the patient's ability to appreciate cervical spine pain |

Patient is very unlikely to have c-spine injury if NONE of the above 5 criteria are present AND

- NO neck pain, bruising or deformity of neck + has full range of active neck movement (45° rotation left and right)^{2,4} **AND**
- NO other high risk factors ie:^{2,6}
 - age > 65 (higher incidence of degenerative disease)^{4,6}
 - fall + landing head first from a height eg diving, trampolining⁵
 - forced neck hyperflexion (low speed, high force eg rugby scrum collapse)²
 - high risk motor vehicle/bicycle accident eg head on collision, rollover, ejection from vehicle, death in same crash, speed > 88 km/hour^{2,4}
 - substantial torso injury (clavicles, abdomen, flanks, back, spine, pelvis), or thoracic/lumbar spine or face

How to log roll^{1,4} Min. of 3, preferably 5, people needed

- 1 person takes the lead. They are positioned at the patient's head to provide manual in-line stabilisation (with 2 hands) to the head and neck. This person gives instructions to the rest of the team
- 3 people (if available) perform the roll:
 - position along the patient's body opposite to the direction that the patient's head is facing
 - 1 at shoulders/chest; 1 at hips; and 1 in control of the legs
 - roll slowly maintaining spinal alignment, avoiding flexion, rotation, lateral bending, sagging of chest or abdomen. Keeping the patient's nose in line with the umbilicus at all times
- 5th person examines back, inserts/removes spinal board etc

4. Management

- If ANY NEXUS criteria, urgently consult MO/NP - requires evacuation ± CT scan^{4,5}
- **Consult MO/NP for clearance before stopping c-spine precautions, regardless of NEXUS criteria**
 - generally, if patient is alert, without neurological deficit, sober, does not have additional painful injuries, and has no pain along spine or neck, it is unlikely they have a spinal injury⁴
- Offer analgesia ± antiemetic. See [Acute pain, p. 32](#), [Nausea and vomiting, p. 40](#)
- If breathing difficulties - monitor SpO₂, capnography (if able) + VBG
- Continue to manage in collaboration with MO/NP until evacuation, which may include:
 - vital signs + neurological observations
 - monitoring respiration
 - nil by mouth
 - keep warm
 - IDC ± oro/nasogastric tube⁵
- If hypotensive consider neurogenic shock if hypovolaemia ruled out. **Note:** haemorrhage is most common cause of shock in trauma⁵
- If paraplegia or a level of sensory loss on the chest or abdomen, presume spinal instability:⁴
 - do not try to reduce an obvious deformity⁶

Moving patient with suspected spinal injury^{1,3}

- Provide in-line immobilisation of the c-spine during transfer and movement of the patient (manually support)
- Use scoop stretcher or log roll onto spinal board/vacuum mattress
- Do NOT leave on rigid spinal board - high risk of pressure ulcers/necrosis
- Use head blocks/sandbags to maintain cervical alignment⁶ - DO NOT strap as significant aspiration risk
- If extended immobilisation, straighten bedding and remove debris from under patient

5. Follow up

- As advised by MO/NP

6. Referral/consultation

- As above

HMP Abdominal injuries - adult/child

Background

- Missed abdominal injuries are a major cause of avoidable death in trauma patients¹
- The absence of abdominal pain does not rule out the presence of significant abdominal injury²

1. May present with

- Abdominal trauma
- General trauma

2. Immediate management

- Do primary survey **DRSCABCD** as per [Traumatic injuries, p. 134](#) + initiate any lifesaving measures
- Assess against [Criteria for early notification of trauma for interfacility transfer \(inside front cover\)](#)

3. Clinical assessment¹⁻³

- Do secondary survey **EFGHIJ** as per [Traumatic injuries, p. 134](#) including **examination of abdomen**
- Do eFAST if trained/available:
 - significant blood loss can occur without change to size of abdomen
 - **note:** –ve eFAST is not accurate in haemodynamically stable patient
- Urinalysis + pregnancy test if female of reproductive age²
- Repeated abdominal assessment needed, as life-threatening injury may not be obvious on initial assessment
- Consider concurrent [Fractured pelvis, p. 156](#)

4. Management¹⁻³

- Offer analgesia eg morphine or fentanyl. See [Acute pain, p. 32](#)
- Nil by mouth
- Keep warm
- Urgently consult MO/NP who may advise:
 - urgent evacuation
 - airway/ventilation support as needed + O₂
 - IV fluids - if haemodynamically compromised, to maintain sBP of 90
 - NG tube if no signs of facial/base of skull injury - on free drainage/aspirate periodically

Blunt injury eg fall from height, steering wheel, being forcefully struck, bicycle related, sports injury

- Can cause:¹⁻³
 - haemorrhage; solid organ injury eg liver/spleen, or hollow viscus injuries eg bladder/bowel
 - contamination by visceral contents + peritonitis
 - pelvic injuries
- Suspect serious injury if:¹
 - rebound tenderness, distension or guarding
 - seatbelt injury or concomitant femur fracture
 - signs of shock (cool, ↑ HR)

Penetrating injury eg gunshot, stab wounds

- May cause injury to liver, spleen, bowel, diaphragm, vessels²
- Do NOT remove impaled object(s) eg knife - removal can cause catastrophic haemorrhage¹
 - VERY CAREFULLY pack around object with gauze soaked in sodium chloride 0.9% and secure (packing/securing can result in further injury)
- If open wound, pack with soaked sodium chloride 0.9% pack
- Exposed bowel should be replaced if able to be done gently, otherwise cover with generously soaked sodium chloride 0.9% packs⁴
- If not evacuated, MO/NP may advise discharge after a period of observation:
 - advise to return immediately if symptoms worsen eg ↑ pain, ↑ HR, ↑ T or swelling of abdomen

Pregnant woman with abdominal trauma^{2,5}

- If > 20 weeks pregnant (uterus at level of umbilicus) - baby can compress the vena cava causing hypotension if lying flat:
 - lie on left side, or if spinal precautions/lying on back, elevate the right side 15–30° by placing a rolled towel/wedge under hip
- Can lose a significant amount of blood before ↑ HR, hypotension/signs of shock occur
- Blunt trauma (even minor) can cause placental abruption. See [APH, p. 390](#)
- Seek obstetric advice⁵ +
 - check for vaginal loss/bleeding
 - fetal heart rate (if skilled) + ask about baby's movements (normal or decreased)
 - monitor for contractions
 - if Rh D –ve blood group, see [Rh D immunoglobulin, p. 369](#)
- If ≥ 23 weeks pregnant, CTG (if available) for at least 4 hours
- Also see Qld Clinical Guideline *Trauma in pregnancy* <https://www.health.qld.gov.au/qcg/publications#maternity>

5. Follow up

- If not evacuated, advise to be reviewed the next day, or sooner if concerned:
 - consult MO/NP if ↑ pain, ↑ HR, ↑ T or any abdominal finding

6. Referral/consultation

- Consult MO/NP with any findings as above or if at high risk of serious injury because of circumstances

Fractures, dislocations and sprains

HMP Simple fracture of limbs - adult/child

Recommend

- Always consider non-accidental injury if presentation is inconsistent with history/explanation, is unexpected or you suspect abuse¹

Background

- Long bone fractures can result in major blood loss²

Related topics

[Dislocations, p. 158](#)

[Sprains/soft tissue injury, p. 159](#)

1. May present with²

- Injury + pain
- ± swelling, bruising, deformity, ↓ range of motion (ROM)

2. Immediate management

- Do primary + secondary survey as per [Traumatic injuries, p. 134](#)
- Assess against [Criteria for early notification of trauma for interfacility transfer \(inside front cover\)](#)
- **Immobilise/apply splint:**²
 - in neutral position if possible. If significant deformity get advice from MO/NP
 - immobilise joints above + below suspected fracture
 - if femur use traction splint eg femoral splint **or** adjacent leg as a splint¹
 - vacuum splint for all others¹
 - arm fractures use removable splint/sling
- Check neurovascular status before + after doing anything to the injured limb
- Offer analgesia. See [Acute pain, p. 32](#)
- **Note:** if pain out of proportion to what would be expected ± not responding to analgesia, suspect [Compartment syndrome, p. 160](#)
- **Consult MO/NP urgently if:**
 - if neurovascular compromise + skin over fracture site is blistering, white or stretched - ↑ risk of becoming open fracture, requires urgent reduction²
 - signs of neurovascular compromise distal to the site eg:
 - weakness or numbness
 - ↓ or absent pulses, delayed capillary refill
 - changes in colour
- If broken bone with wound ± visible bone, see [Open fractures, p. 154](#)

3. Clinical assessment

- **Ask about mechanism of injury +**
 - timing + events surrounding the injury
 - any witnesses, any first aid¹
 - if lower limb - could they weight bear immediately after injury - if not, may indicate fracture³
- **Get past history,** including:
 - previous fractures, when, treatment

- orthopaedic surgery
- comorbidities eg osteoporosis, arthritis, diabetes
- risk factors for complications eg immunocompromised, PVD, alcohol misuse, anticoagulants³
- **Check limb** + compare with other side for:
 - deformity, swelling, wounds
 - bruising, expanding haematoma¹
 - range of motion - painful or limited
 - inability to weight bear if lower limb^{4,5}
- Examine joints above + below for associated injuries eg elbow if fall onto outstretched hand⁵
- If elderly + fall - check for other injuries

4. Management

- Consult MO/NP for all suspected fractures who may advise:
 - x-ray + backslab
 - nil by mouth
 - evacuation
- **Note:** after a fall on outstretched hand a scaphoid fracture may not be seen on x-ray. If tenderness, immobilise until follow up x-ray in consultation with MO/NP
- Keep warm + closely monitor until evacuation:⁶
 - vital signs + neurovascular observations + signs of [Compartment syndrome, p. 160](#)
- If not evacuated, ongoing management as per MO/NP

Plaster backslab ^{2,4}	
Positioning of slab	<ul style="list-style-type: none"> • Discuss with MO/NP + see Backslabs for guidance
What you need	<ul style="list-style-type: none"> • Plaster bandages eg 7.5/10 cm - short arms/wrists, 15/20 cm - long arm • Undercast padding • Bowl of cold water + trauma scissors • Crepe bandages ± sling
How to do	<ul style="list-style-type: none"> • Remove all rings, bracelets, watches, restrictive clothing, shoes² • Apply 2–3 layers of padding + 50% overlap beyond margins of plaster • Measure a length of plaster 1 cm shorter than the padding/stockinette at each end. Fold the roll in about ten layers to the same length • Submerge in water until bubbling stops, remove + squeeze out excess • Lightly mould to the contours of the limb in a neutral position • Plaster must not fully encircle the limb • Turn back padding over ends of plaster + apply crepe bandage firmly over slab • Elevate limb on pillows or sling for arm • Advise patient it may take 4–6 weeks to heal + Plaster care ± crutches if not evacuated
Plaster care advice ⁴	<ul style="list-style-type: none"> • Elevate limb above level of heart when possible using a sling/pillows, will ↓ pain + swelling • Exercise fingers/toes + other joints that aren't covered by the plaster by bending/stretching/wiggling them • Avoid applying pressure + heat to the cast • Use plastic bag to protect plaster while in shower + do not scratch under the cast with a sharp object, if damaged return to clinic

Backslabs

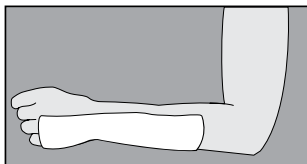

Short arm plaster backslab

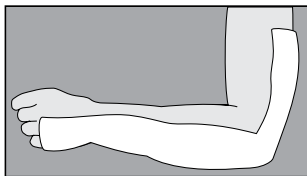

Long arm plaster backslab

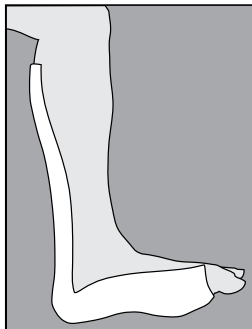

Short leg plaster backslab

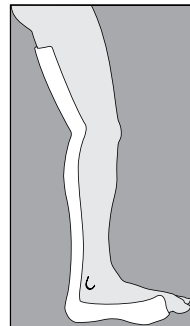

Long leg plaster backslab

5. Follow up

- If not evacuated advise patient to be reviewed next day or sooner if needed:
 - if ↑ pain or swelling, numbness, tingling or skin colour changes to blue or white⁶ - urgently contact MO/NP

6. Referral/consultation

- Physiotherapist where possible

HMP Open (compound) fractures - adult/child

Recommend

- Urgent surgical review. Keep nil by mouth + give antibiotics, ideally within 3 hours of injury¹

1. May present with

- Open wound on same limb segment as an associated fracture²
- Bone has broken the skin or mucous membrane ± visible bone¹
- Wound may be small eg puncture³

2. Immediate management

- Do primary + secondary survey as per [Traumatic injuries, p. 134](#)
- Assess against [Criteria for early notification of trauma for interfacility transfer \(inside front cover\)](#)
- Stop any bleeding by putting pressure on wound, not on exposed bone¹
- If signs of neurovascular compromise contact MO/NP urgently +
 - thoroughly irrigate with sodium chloride 0.9%
 - give antibiotics + requires urgent reduction
- Immobilise/apply splint as per [Simple fracture of limbs, p. 152](#):
 - irrigate with sodium chloride 0.9% if severely contaminated wound.³ **Do not probe²**
 - **do not irrigate open fractures of the long bones or foot⁴**
 - apply a saline-soaked dressing covered with an occlusive layer^{3,4}

- Insert IVC
- Give analgesia. See [Acute pain, p. 32](#)

3. Clinical assessment^{1,3}

- Assess as per [Simple fracture of limbs, p. 152](#) +
 - ask if contaminated environment eg agricultural, sewage, fresh or salt water¹
- Check tetanus vaccination status and give booster if indicated. See [Tetanus immunisation, p. 557](#)

4. Management

- Urgently consult MO/NP who may advise:
 - IV cefazolin ± IV metronidazole¹
 - x-ray, backslab, evacuation
 - neurovascular observations
 - nil by mouth

S4	Cefazolin			Extended authority ATSIHP/IHW/IPAP
ATSIHP, IHW, IPAP, RIPRN and RN must consult MO/NP				
Form	Strength	Route	Dose	Duration
Injection	1 g	IV	Adult 2 g	stat
			Child 50 mg/kg (max. 2 g)	Inject slowly over at least 5 minutes
Offer CMI: May cause diarrhoea, nausea, vomiting, rash, headache or dizziness				
Contraindication: Allergy to cephalosporins or if severe or immediate allergic reaction to a penicillin. Be aware of cross-reactivity between penicillins, cephalosporins and carbapenems				
Management of associated emergency: Consult MO/NP. See Anaphylaxis, p. 82				^{1,5}

S4	Metronidazole			Extended authority ATSIHP/IHW/IPAP
ATSIHP, IHW, IPAP, RIPRN and RN must consult MO/NP				
Form	Strength	Route	Dose	Duration
Injection	500 mg/100 mL	IV	Adult 500 mg	stat
			Child 12.5 mg/kg (max. 500 mg)	Infuse over 20 minutes
Offer CMI: May cause nausea, anorexia, abdominal pain, vomiting, diarrhoea, metallic taste, dizziness, headache or thrombophlebitis				
Management of associated emergency: Consult MO/NP. See Anaphylaxis, p. 82				^{1,6}

5. Follow up

- As per MO/NP advice

6. Referral/consultation

- All open fractures require consultation with local orthopaedic services

HMP Fractured pelvis - adult/child

1. May present with

- Suspected pelvic fracture post trauma eg:¹
 - tenderness of pelvic area
 - abnormal rotation of affected leg ± shock
- Major haemorrhage¹ + likely to have other injuries

2. Immediate management

- Do primary survey **DRSCABCD** as per [Traumatic injuries, p. 134](#) + initiate any life saving measures
- **Consult MO/NP/RSQ urgently - suspected fractured pelvis requires Early notification of trauma for interfacility transfer (inside front cover)**
- Do not spring the pelvis to check for stability - may dislodge clots + cause catastrophic haemorrhage²
- **Apply pelvic binder urgently** to ↓ risk of haemorrhage, even if low suspicion of fracture:³⁻⁵
 - slide under the legs + then buttocks⁶
 - apply over the greater trochanters + symphysis pubis region, **do not apply above iliac crests**¹
 - secure firmly, should be able to insert 2 fingers between patient + binder⁷
 - use sheet if binder not available
- Insert IVC x 2
- Give IV morphine or fentanyl. See [Acute pain, p. 32](#)
- Only log roll to clear airway if suction is ineffective/not available - may cause haemodynamic instability^{5,8}

3. Clinical assessment

- Do secondary survey **EFGHIJ** as per [Traumatic injuries, p. 134](#)
- Also check:¹
 - lower leg - pulses, power, sensation - any ↓
 - for blood at urethral opening + scrotal bruising - in males
 - urinalysis - for blood if possible, or take from IDC if inserted
- May also have genitourinary + [Abdominal injuries, p. 150](#)

4. Management

- MO/NP will advise further management eg x-ray is important if available
- Gently insert IDC if delay to evacuation
- Transport on scoop where possible⁵
- Keep warm + closely monitor until evacuation:
 - vital signs + signs of hypovolaemic shock
 - lower leg - pulses, power, sensation + pain

5. Follow up

- As per MO/NP/RSQ advice

6. Referral/consultation

- As above

HMP Fractured jaw - adult/child

Recommend

- Be alert to airway obstruction from bleeding or swelling

1. May present with

- Trauma to face + pain, swelling, bleeding, deformity, drooling^{1,2}

2. Immediate management

- Do primary survey **DRSCABCD** as per [Traumatic injuries, p. 134](#)
- Assess against [Criteria for early notification of trauma for interfacility transfer \(inside front cover\)](#)
- Consider need for [c-spine immobilisation, p. 147](#)

3. Clinical assessment

- **Ask about mechanism of injury +**
 - timing + events surrounding the injury
 - any witnesses, any first aid
- Do vital signs + secondary survey **EFGHIJ** as per [Traumatic injuries, p. 134](#)
- Assess as per [Head injuries, p. 143](#)
- Do full facial examination, including:
 - **check for signs of fractured jaw:**
 - clenched teeth not 'fitting together' as usual/misaligned
 - limited or painful mouth opening¹
 - unable to maintain bite on tongue depressor while twisted²
 - flattening, swelling of cheeks
 - difficulty swallowing²
 - **any other injuries eg:**²
 - mouth + tongue - lacerations, swelling
 - broken teeth - keep knocked out teeth for possible replacement. See [Trauma to teeth, p. 257](#)
 - orbit - palpate for step defect, numbness - may indicate fracture

4. Management

- Consult MO/NP who may consider:
 - IV antibiotics, x-ray, nil by mouth
 - evacuation/hospitalisation for surgical review
- Offer analgesia. See [Acute pain, p. 32](#):
 - consider ice packs + soft collar for comfort¹
- Check tetanus vaccination status and give booster if indicated.¹ See [Tetanus immunisation, p. 557](#)
- Consider [Domestic and family violence, p. 241](#)
- Closely monitor until evacuation + frequent airway checks

5. Follow up

- As per MO/NP

6. Referral/consultation

- As above

HMP Dislocations - adult/child

Background

- Pulling or pushing of a bone out of its normal position in the joint¹

1. May present with

- Injury + severe pain that is worse on movement + very apprehensive to move joint²
- ± deformity, associated fractures
- Reports of popping or joint rolling out of place - mainly shoulder dislocations¹

2. Immediate management

- Offer analgesia. See [Acute pain, p. 32](#)
- Support limb using pillows as needed + apply ice packs as tolerated
- If simple dislocation eg patella, digit + skilled - quickly reduce to alleviate pain
- Contact MO/NP if signs of neurovascular compromise distal to the site eg:
 - weakness or numbness
 - ↓ or absent pulses, delayed capillary refill
 - changes in colour

3. Clinical assessment

- Ask about mechanism of injury +
 - timing + events surrounding the injury. Any witnesses, any first aid
- Get past history:
 - previous dislocations, when, was it reduced, if so how/which manoeuvre¹
 - any orthopaedic surgery or underlying conditions eg osteoporosis²
- Do physical examination, including:^{1,2}
 - vital signs
 - check range of motion - painful or limited + palpate joints above and below injury - any tenderness, swelling

4. Management

- Consult MO/NP who may advise:
 - x-ray to check for fracture + if can be reduced locally, or
 - evacuation/hospitalisation
- Collaborate with MO/NP on reduction manoeuvres - if skilled + appropriate. Consider:
 - nil by mouth
 - IV analgesia/sedation or methoxyflurane or nitrous oxide + O₂ (Entonox®)¹
 - monitor neurovascular status before + after reduction:
 - if shoulder - check sensation over deltoid muscle, nerve can be damaged during reduction
 - after care eg x-ray + immobilise joint/limb²

5. Follow up

- As per MO/NP

6. Referral/consultation

- Refer to physiotherapist if available

HMP Sprains/soft tissue injury - adult/child

Recommend

- Be alert to associated injuries eg fractures + dislocations¹
- In children consider fibula fracture, often misdiagnosed as a sprain

Background

- Sprain is over stretching to incomplete or complete tear of the ligament²

1. May present with

- Injury + swelling, bruising + pain on movement²
- No fracture seen on x-ray

2. Immediate management

- Contact MO/NP if signs of neurovascular compromise distal to the site eg:
 - weakness or numbness
 - ↓ or absent pulses, delayed capillary refill
 - changes in colour + T
- Offer analgesia. See [Acute pain, p. 32](#)
- Support limb using pillows as needed + apply ice packs

3. Clinical assessment

- If child, infections of joints often present with a history of injury. See [Swollen/painful joint, p. 550](#)
- **Ask about mechanism of injury +**
 - timing + events surrounding the injury
 - any witnesses, any first aid
 - if ankle - could they weight bear immediately after injury - if not may indicate fracture²
- Get past history:
 - similar injury, when, treatment - ankle sprains are often recurrent²
- Do physical examination, including:¹
 - vital signs
 - check for signs of **severe sprain**:
 - severe pain, extensive bruising + swelling
 - complete inability to weight bear
 - loss of motion + stability + abnormal joint movement
 - palpate joints above + below injury - any tenderness, swelling

4. Management

- **If severe** contact MO/NP, who may advise:
 - x-ray ± cast for 10–14 days + non-weight bearing activity/crutches
- **If mild or moderate sprain:**
 - Rest + limit activity until pain free use is possible:²
 - may need crutches for 2–3 days until standing is no longer painful^{1,3}
 - Ice for 48 hours - apply for 20 minutes on/20 minutes off as needed for pain/swelling²
 - Compression for 1st few days - bandage is better for ↓ swelling than rigid splint²
 - Elevate above level of heart to ↓ pain + swelling²
 - Refer to physiotherapist if available

- Reassure patient pain should ↓ gradually + most sprains heal well^{1,2}

5. Follow up

- Advise patient to be reviewed if:^{2,3}
 - changes to limb/joint - T, pallor, numbness, pins + needles or swelling
 - pain continues, increases or is not relieved by analgesia
 - contact MO/NP + consider fracture, compartment syndrome

6. Referral/consultation

- As above

HMP Compartment syndrome - adult/child

Recommend

- Limb threatening emergency - urgent evacuation for surgical management^{1,2}
- Be alert in all limb injuries eg closed leg + forearm fractures, crush injuries or treatment causing compression/constriction eg casts/splints, circumferential bandaging²

Background

- Hypoxia of muscle + nerves caused by bleeding + swelling in closed muscle cavity, leading to necrosis + amputation¹

1. May present with

- Limb injury + pain out of proportion to what would be expected ± not responding to analgesia¹
- If child - anxiety, agitation, unable to rest comfortably³

2. Immediate management

- Remove any bandaging, casts/splints to relieve pressure:³
 - leave a portion of cast/splint to stabilise fracture as needed
- Rapidly assess:²
 - pain - severity, is it responding to analgesia
 - passively extend fingers/toes distal to injury, does this cause pain
 - any ↓ sensation, numbness, pins + needles + absent pulses - compare to opposite limb^{1,4}
- Contact MO/NP urgently, even if low suspicion of compartment syndrome²
- Offer analgesia. See [Acute pain, p. 32](#)
- Rest, apply ice packs + elevate the limb to heart level with pillows^{1,4}
- Insert IVC

3. Clinical assessment

- Ask about:
 - mechanism of injury, when, treatment so far
 - underlying bleeding disorders, anticoagulants²
- Do physical examination, including:
 - vital signs
 - check entire limb for swelling³
 - palpate muscles - firm, tight, tenderness³

4. Management^{1,4}

- Consult MO/NP who will:
 - order x-ray to exclude displaced fracture
 - arrange urgent evacuation
 - advise further management eg splinting of limb to prevent further ↑ pressure
- Nil by mouth
- Closely monitor until evacuation:²
 - vital signs + neurovascular observations at least hourly
 - pain

5. Follow up

- As per MO/NP

6. Referral/consultation

- As above

Acute wounds

HMP Acute wounds - adult/child Wound repair

1. May present with

- Acute traumatic wound eg laceration, abrasion, tear, scrape
- Blood under nail with pain

2. Immediate management

- Apply direct pressure for 10–15 minutes to control bleeding:¹
 - if bleeding persists, consider suturing/stapling (or using hair as a tie for scalp)²
 - see [Traumatic injuries](#), p. 134 as relevant
- Do not remove any penetrating foreign body eg knife, unless advised by MO/NP to do so³
- If shock **from blood loss** (cool, HR > 100, capillary refill > 2 seconds):³
 - insert IVC x 2
 - IV fluid bolus (warmed if possible) - sodium chloride 0.9% or Hartmann's:
 - **adult** 1 L (250 mL increments, aim to maintain SBP at 90). **Child** 10–20 mL/kg
- If **bat bite** or scratch, see [Bat bite/scratch](#), p. 176 - **requires urgent treatment**
- Offer analgesia. See [Acute pain](#), p. 32 ± consider local anaesthetic

3. Clinical assessment^{1,4}

- Get history including:
 - mechanism of injury/how it happened
 - time/date of injury
 - where did it occur eg dirt, oil, water, mud, other contaminated area
- Get past history, including:
 - diabetes, smoking, peripheral vascular disease
 - steroid medicines
 - bleeding disorder/anticoagulants
- Do vital signs
- **Assess wound:**
 - site:
 - if chest or abdomen, be wary of penetration through the body wall - consult MO/NP as needed
 - size - length + depth
 - skin or tissue loss
 - direction of entry. This will help track the wound
 - bony tenderness - suggests an underlying fracture. See [Open fractures](#), p. 154
 - swelling - suggests bleeding into the tissues
 - any bones, joints, vessels, nerves, muscles damaged²
 - if stab wound, evaluate for depth/underlying damage - consult MO/NP¹
- **Could there be a foreign body (FB).** Suspect if:¹
 - stepping on anything eg glass, wood/sticks, metal, fish barbs, bones
 - projectiles thrown by machinery
 - assault eg knives, bottles, glass, spears, arrows
 - limb going through glass

- **Check:**¹
 - colour, warmth and pulses distal to the wound
 - sensation around and below the wound (before putting in anaesthetic)
 - movement of joints above and below the wound
- **If arm or hand injury:**⁵
 - assess tendons of the hand through range of motion:
 - extensors - straighten the fingers against resistance
 - flexors - make a fist
 - thumb - raise it to the ceiling (palm up) + make an 'O' with the little finger, both against resistance
- **X-ray or USS may be indicated if:**¹
 - underlying fracture suspected
 - foreign body suspected but cannot be identified visually:²
 - **note:** no foreign body on x-ray does not exclude a FB in the wound, unless you are sure it would be radio-opaque
- If wound looks infected, take swab for MCS.⁶ See [How to take a wound swab, p. 324](#)

4. Management²

- If [tetanus prone wound, p. 557](#) check vaccination status and give booster if indicated
- If wound over a fracture or penetrating wound into joint, see [Open fractures, p. 154](#)
- Consult MO/NP if:¹
 - damaged tendons, nerves, vessels or fracture suspected
 - systemic infection eg fever, malaise **OR** localised infection involving deeper tissues (eg bones, joints or tendons) **OR** penetrating wound through footwear⁶
- Remove rings, watches etc from the affected limb
- **Clean wound thoroughly** - important to prevent infection:¹
 - may need to use local anaesthetic prior to cleaning
 - use sodium chloride 0.9% or tap (drinking) water:⁷
 - ensure dirt, grass, other contamination is removed
 - **deeper wounds** need irrigation to get dirt out:¹
 - running tap water, or use 18 G cannula, without the stylet + 20–50 mL syringe
 - repeat a number of times - may need 500 mL or more
 - **gravel rash** - if bitumen and dirt ground into skin with abrasion, after anaesthetic, scrub with a brush to remove ground in dirt⁸
- **If foreign body possible:**
 - explore wound - use small probe or forceps. Can often feel foreign body before seeing it
 - do not explore deep wounds with spurting blood or near large vessels eg neck, groin, armpits
 - if glass - may be fragments remaining - consult MO/NP¹

Antibiotics⁶

- Not usually needed for recent clean wounds, especially if cleaned properly
- **May be needed if:**
 - sustained in water eg coral cuts, stingray barb, fish hook. See [Water related wounds, p. 170](#)
 - bite - [Human and animal bites, p. 173](#)
 - over a fracture. See [Open fractures, p. 154](#)
 - significantly contaminated eg through footwear, stab wound, or requiring surgical management:
 - consult MO/NP
 - localised infection eg redness, pus. Give antibiotics as per mild [Cellulitis, p. 306](#)⁶ **OR** [Water related wounds, p. 170](#) **OR** [Bites, p. 173](#) if indicated. Also consider retained FB

Wound management options.^{1,8} Also see **Special sites/considerations** (next page)

- Leave open to the air eg grazes and superficial cuts in clean dry areas of the body
- Simple dressings eg for grazes and small cuts, not gapping
- Wound closure/repair
- Healing by secondary intention (no formal closure) eg if a deep stab/puncture wound, infection, contaminated or > 24 hours old

Wound closure/repair

- Primary closure - if clean wound < 12–18 hours old (or up to 24 hours if head wound):^{1,2}
 - **do not close if:**⁴
 - dirty, contaminated, infected or at high risk of infection eg deep puncture wounds, [Bites](#), p. 173 or [Water related wounds](#), p. 170
- Delayed primary closure - delay repair for 3–5 days to allow for proper cleaning:
 - eg for dirty or complex wounds. Usually needs debridement before closure. Consult MO/NP

Primary closure options

Goal is to stop bleeding and achieve optimal cosmetic results without increasing risk of infection²

Option	Indications
Adhesive strips ⁸ eg Steri-Strip®	<ul style="list-style-type: none"> • Simple lacerations with slightly separated wound edges • Not suitable if movement or tension across the wound or oozing blood • Skin tears in the elderly/wounds over the shin, even large ones • Skin barrier wipe eg 3M Cavilon®, on the skin helps them stick
Tissue (skin) adhesive ^{2,8}	<ul style="list-style-type: none"> • Wounds < 3 cm, with clean edges that are easily held together • DO NOT use around eyes or on mucosal surfaces, or if actively oozing blood
Sutures ⁴	<ul style="list-style-type: none"> • Larger wounds, areas with high skin tension, over joints/moving areas • Do not suture if a lot of tension needed to bring it together eg tissue loss
Staples ⁹	<ul style="list-style-type: none"> • Useful for linear wounds on scalp, trunk, arms, legs • DO NOT use on face, neck, hands or feet • Align wound edges, staple across wound, about 0.5–1 cm apart • Need staple remover on hand
Hair apposition technique ² If hair ≥ 3 cm long	<ul style="list-style-type: none"> • Cost effective, fast, less painful approach to scalp laceration repair < 10 cm • Twist together 3–7 strands of hair on 1 side of wound. Do the same on the other side. Interlock by twisting together 360°. No need to tie a knot • Secure intertwined hair bundles with a few drops of skin adhesive

Preparation for wound repair¹

- **Local anaesthetic** options:²
 - lidocaine (lignocaine) 1% - use for most wounds. Inject via the wound and under the skin (don't go through the normal skin, it hurts more)
 - lidocaine (lignocaine) 1% with adrenaline (epinephrine) 1:100,000 for longer lasting anaesthetic + reduction of bleeding
 - topical lidocaine (lignocaine) + tetracaine (amethocaine) + adrenaline (epinephrine) gel eg Laceraine® (eg in children)
 - **Digital nerve block** for fingers/toes
- **Debride as needed** - remove dead/dying tissue from in/around wound. Use scalpel or scissors
- Do not remove hair unless it interferes with wound closure or knot formation:
 - do not shave; do not remove eyebrows¹

S ₄	Lidocaine (lignocaine)			Extended authority ATSIHP/IHW/RIPRN
ATSIHP, IHW and RN must consult MO/NP				
RIPRN may proceed				
Form	Strength	Route	Dose	Duration
Injection	1% 50 mg/5 mL	Subcut	up to 3 mg/kg (max. 200 mg)	stat
Offer CMI: It will hurt as it goes in. Report any drowsiness, dizziness, blurred vision, vomiting or tremors				
Note: Use the lowest dose that results in effective anaesthesia				
Management of associated emergency: Ensure resuscitation equipment readily available. Consult MO/NP. See Anaphylaxis, p. 82				

S ₄	Lidocaine (lignocaine) + adrenaline (epinephrine)			Extended authority ATSIHP/IHW/IPAP/RIPRN
ATSIHP, IHW, IPAP and RN must consult MO/NP				
RIPRN may proceed				
Form	Strength	Route	Dose	Duration
Injection	Lidocaine (lignocaine) 1% (50 mg) + adrenaline (epinephrine) 1:100,000/5 mL	Subcut	Adult and child > 12 years up to 7 mg/kg (max. 500 mg) <i>Dose as per lidocaine component</i>	stat
Offer CMI: It will hurt as it goes in. Report any drowsiness, dizziness, blurred vision, vomiting, tremors or anxiety. May cause pallor, tachycardia, hypertension, sweating or arrhythmias				
Note: Use the lowest dose that results in effective anaesthesia. Use with caution in fingers, toes and ears				
Contraindication: Avoid in Raynaud's phenomenon or if peripheral vascular disease. Do not use on penis or tip of nose				
Management of associated emergency: Ensure resuscitation equipment readily available. Consult MO/NP. See Anaphylaxis, p. 82				

S ₃	Lidocaine (lignocaine) + tetracaine (amethocaine) + adrenaline (epinephrine) eg Laceraine®			Extended authority ATSIHP/IHW/IPAP
ATSIHP, IHW, IPAP, RIPRN and RN may proceed				
Form	Strength	Route	Dose	Duration
Gel	Lidocaine 4.2% + tetracaine 0.5% + adrenaline (epinephrine) 0.2%/4 mL	Topical	0.1 mL/kg (1–3 years: max. 2 mL) (> 3 years: max. 3 mL)	stat
Offer CMI: Stinging can occur initially. Anaesthesia lasts for 40–60 minutes				
Note: Apply to wound directly or with a cotton tipped applicator, then cover with occlusive dressing. Leave for 20–30 minutes (max. 60 minutes) - blanching of the area should occur. Then remove dressing and gel				
Contraindication: Do not apply to extremities eg fingers, toes, ears, nose due to risk of ischaemia. Do not apply to mucous membranes				
Management of associated emergency: Consult MO/NP. See Anaphylaxis, p. 82				

Digital nerve block¹

- Infiltrate lidocaine (lignocaine) 1% near the digital nerve on each side of the dorsum of the finger, avoiding the joint. Keep infiltration as close to the bone as possible
- Use approximately 1–2 mL of lidocaine (lignocaine) on each side
- Draw back regularly to avoid injecting into a blood vessel
- Wait at least 5 minutes for the anaesthetic to take effect

**Suturing^{2,4}**

- For skin use polypropylene eg Prolene® or nylon eg Ethilon®²

Area	Size (approx.)	Removal ^{2,4}
Face, neck	5/0	3–5 days
Scalp	3/0	7–10 days
Digits, palm, sole	4/0, 5/0	10–14 days
Legs, trunk	3/0, 4/0	7–10 days
Arms		

- Use smallest suture that will give sufficient strength to bring edges together and support the wound
- **Placing suture(s):**
 - aim to evert skin edges, like puckered lips
 - enter skin at 90° angle, about 5 mm from the wound edge. Go straight down, across, then straight up and exit the skin about 5 mm from the other edge
 - place first suture halfway along the wound and continue to divide the wound in half. The first suture may lose tension when the others are completed. If so, take it out and re-insert new suture
 - when suturing a 'V' or 'Y' shaped wound, align the point of the 'V' first
 - if the wound crosses wrinkles or skin creases, line up as well as possible
- Take sutures out if they are in the wrong place and re-insert
- **If you are not happy repairing any wound, don't do it. Consult MO/NP**
- **Note:** sutures can cause a pink foreign body inflammation around the wound

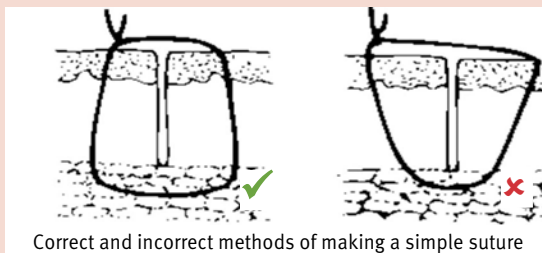

Correct and incorrect methods of making a simple suture

Tissue adhesive^{2,8} eg Dermabond®

- Do NOT allow adhesive to get into the wound - will act like a foreign body
- Bring wound edges together and apply very small amount of adhesive to surface
- Hold edges together for 30 seconds
- Repeat with layers of adhesive (at least 3), allowing time for drying between each application
- **Note:**
 - avoid contact around eyes - if applying to forehead pad the eye to avoid adhesive dripping into eye
 - do not use over bleeding wounds
 - avoid gluing yourself (eg gloves or equipment) to the patient
- Does not require removal - comes off in 1–2 weeks

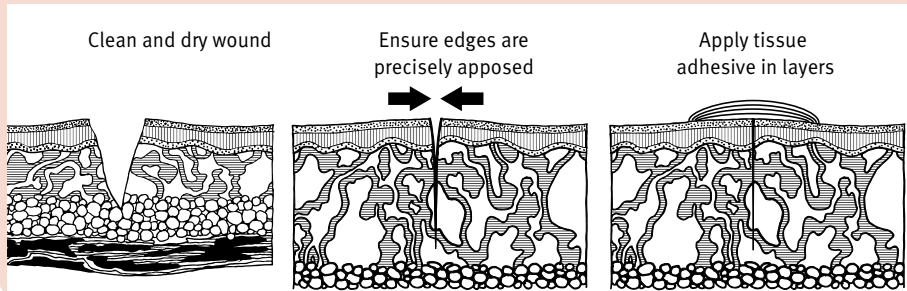
**Special sites/considerations**⁴

Face ²	<ul style="list-style-type: none"> • Only repair if confident of getting a good cosmetic result • Limit debridement - increased blood supply to face helps healing + could cause scarring • Be aware that there may be damage to facial nerves
Nose or ears ²	<ul style="list-style-type: none"> • Consult MO/NP. Cartilage has poor circulation and prone to infection + necrosis
Lips ^{2,8}	<ul style="list-style-type: none"> • Lips swell +++ when wounded • Lacerations to inner lips will usually heal without intervention • If the wound crosses the edge of the lip onto normal skin (vermilion border), ensure it is realigned exactly. Place 1st suture at this border + mark border prior to anaesthetic, as may blur border
Inside mouth and tongue ⁸	<ul style="list-style-type: none"> • Sutures not usually needed unless large laceration - consult MO/NP • Will look grey and sloughy after a few days - advise mouth rinses after each meal
Eyelid and Eyebrow ^{2,8}	<ul style="list-style-type: none"> • If eyelid, consult MO/NP - may need ophthalmology referral. Also see Eye injury, p. 286 • Do not use tissue adhesive near eyes • Use edges of eyebrow as landmarks. Put single suture at each margin first to ensure good alignment²
Hand and forearm ²	<ul style="list-style-type: none"> • If suspected tendon, nerve, muscle, vessel, bone or nail bed injury, consult MO/NP - may need specialist review² • Take rings off - fingers swell after injury • Keep sutures to fingers a minimum, as they will pull out of the tissue as the finger enlarges. Most finger lacerations can be treated without sutures. Use Steri-Strips® carefully to keep wound edges approximated: <ul style="list-style-type: none"> – circumferential or tightly tensioned Steri-Strips® can cause vascular occlusion – apply a nonadherent dressing + bandage the whole finger so that it stays in a functional position of minimal flexion

Special sites/considerations (continued)

Small laceration to finger tip

- Skin flap not lost:
 - reapply the flap over the wound and secure it loosely with Steri-Strips®
 - cover with a nonadherent dressing and bandage the finger to keep it straight
 - review in 2–3 days. Hopefully the flap will ‘take’ and act as a graft onto the wound. More often the flap will die off, but at least it covers the wound well until it heals
- Skin loss:⁸
 - if ≤ 1 cm square treat with dressings, usually heal well
 - if > 1 cm consult MO/NP

Crush injury or partial amputation of finger eg in hinge of door, hammer^{8,13}

- **Consult MO/NP**
- If nail lacerated/lifted - where/how much. MO/NP will advise if nail should be removed or replaced. If removed, keep nail as possible splint
- Assess integrity of nail bed - if damaged needs meticulous repair - poor technique results in a permanently split or deformed nail
- Consider x-ray to look for an underlying fracture
- Clean and apply sodium chloride 0.9% dressing to keep moist
- If needed, put amputated part in a clean plastic bag and seal it. Put bag in a mix of crushed ice and water for transport. Do not get it wet/frozen - send with patient when evacuated

Painful subungual haematoma (blood under nail)¹⁴

- If significant pain drain blood from under the nail. Otherwise treat with ice and analgesia⁸
- Use needle or hot cautery method to put hole through nail
- **Needle method:**
 - twirl 18–21 G needle with slow downward pressure until loss of resistance and drainage is seen (avoiding nail bed injury). Multiple holes may be needed for adequate drainage
- **Hot cautery method:**
 - straighten the end of a paper clip and heat with a flame
 - place the hot end on the nail over the centre of the haematoma
- Gently squeeze tip of finger to facilitate drainage
- Irrigate wound with sodium chloride 0.9%

5. Follow up

- Advise:⁴
 - if Steri-Strips® keep dry for 72 hours⁸
 - if wound repaired, leave dressing in place for 24 hours, then leave open to air⁴
 - if wound at higher risk of infection or patient has diabetes/immunocompromised:
 - review in 2–3 days
 - elevate as needed to lessen pain/swelling
 - to return if signs of infection eg redness, pus, swelling, fever
 - when to return for sutures/staple removal. Tissue adhesive (including if used for hair), will come off by itself²

6. Referral/consultation

- Consult MO/NP as above

Removal of small fish hook

- If involves eye consult MO/NP immediately
- Large hooks may require surgical intervention. Consult MO/NP
- Clean area with Betadine® or chlorhexidine ± sodium chloride 0.9% irrigation prior to removal¹
- May need antibiotics. See [Water related wounds, p. 170](#)
- Wear protective eye wear if pulling or cutting hook

Method 1 String yank¹

- Do not use on body part that is not fixed eg earlobe
- Loop a length of string/fishing line around the bend in the hook
- Apply downward pressure to the shank of the hook, to disengage the barb, thereby moving it into the original path of the barb
- Maintaining downward pressure, use a quick, firm tug on the string to remove the hook
- In most cases local anaesthesia is not needed

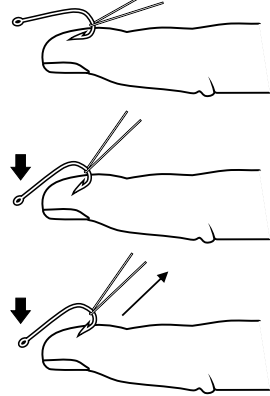

Method 2 Needle cover¹

- Insert an 18 G needle along the barbed side of the hook, with the bevelled part pointing towards the inside of the hook's curve
- Pull gently on the shank to disengage the barb inside of the hook's curve
- Then push the needle gently downwards until its hole locks over the barb
- Rotate the hook shank slightly downward and the hook curve upwards until the needle and hook are removed through the original wound

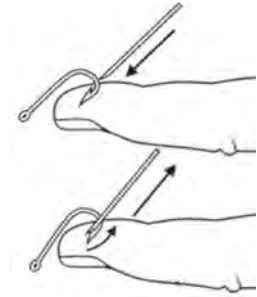

Method 3 Push through and cut off^{1,2}

- Always have forceps (needle holding) gripping at least one end of the hook, so as not to lose the hook
- Grip the hook with forceps, advancing the hook through the tissue until the barb end of the hook penetrates through the skin at a separate location
- Cut the eye off the hook with a pair of wire cutters
- Grip the barbed end of the hook with forceps and guide the hook out

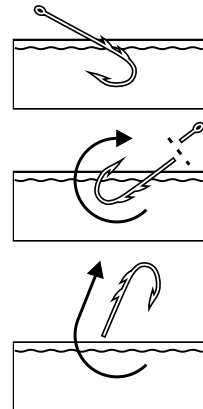

Removal of tight ring¹

- Use thread eg 3/0 nylon suture material, string, dental floss or thin elastic
- Feed one end of thread under ring (a paper clip makes a good hook)
- Tightly wrap the finger with the thread - from proximal to distal end, while keeping tension on the thread
- Pull the proximal end of the thread towards the tip of the finger - the thread will start to unwind as you pull it and push the ring towards the tip
- Gradually the ring will slide over the compressed finger
- Several repetitions of the process may be required
- If unsuccessful use ring cutter

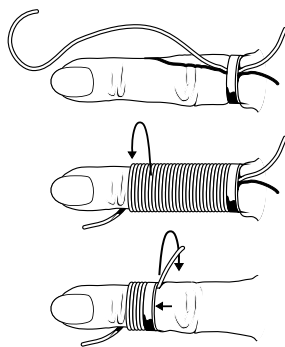

HMP Water related wounds - adult/child

Recommend¹

- Close monitoring of wound infections related to water immersion. Can progress rapidly

Background¹

- Immersion in water includes:
 - fresh or brackish water/mud eg creeks, estuaries, mangrove swamps
 - salt water, swimming pools, fish tanks, ponds

1. May present with¹

- Wound sustained with water immersion or mud eg boat propeller, prawn/crayfish shells, fish spines, coral cut, aquarium objects, surfing, fish hook
- Marine animal bite eg shark, crocodile
- ± signs of infection eg redness, pus, fever

2. Immediate management¹

- Initial management as per [Acute wounds, p. 162](#)
- Do vital signs
- Screen for [Sepsis, p. 64](#)

3. Clinical assessment¹

- Get history and examine wound as per [Acute wounds, p. 162](#), including:
 - when/how the wound occurred
 - type of water immersion eg fresh water/brackish/mud or sea water
 - look for signs of infection eg fever, redness, swelling, pus, [Cellulitis, p. 306](#)
- Get past history including:
 - diabetes, liver disease, immunocompromised, iron overload, malignancy
- If wound infected, take swab for MCS. See [How to take a wound swab, p. 324](#)

4. Management¹

- Offer analgesia. See [Acute pain, p. 32](#)
- Manage as per [Acute wounds, p. 162](#) +
 - irrigate/clean well and debride as needed - **important to prevent infection**
 - do not suture - allow to heal by secondary intention. Consult MO/NP as needed for advice
- Check tetanus vaccination status and give booster if indicated. See [Tetanus immunisation, p. 557](#)
- **Consult MO/NP promptly** (may order IV/oral antibiotics ± evacuation) - **if any of:**
 - systemically unwell eg malaise, fever, chills (insert IVC + blood cultures)
 - deeper tissues, tendons or joints involved (or unsure)
 - diabetes, liver disease, immunocompromised, iron overload, malignancy
- **Otherwise, give oral antibiotics if:**¹
 - mild/localised wound infection **OR**
 - traumatic wound and significantly contaminated or needs surgical management **OR**
 - marine bite, especially if:
 - on hand, feet, face or puncture wound **OR**
 - > 8 hours delay to medical care

Oral antibiotics if indicated¹

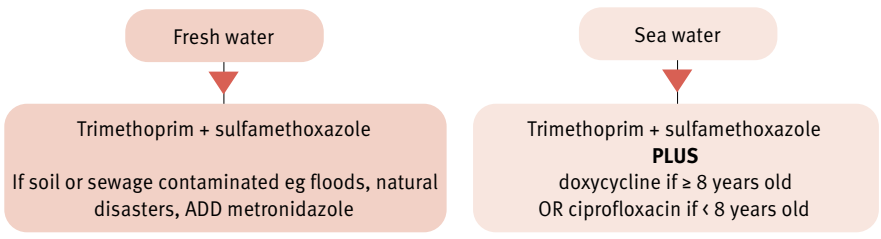

S4	Trimethoprim + sulfamethoxazole		Extended authority ATSIHP/IHW/IPAP/RIPRN	
ATSIHP, IHW, IPAP and RN must consult MO/NP				
RIPRN may proceed				
Form	Strength	Route	Dose	Duration
Tablet	80 + 400 mg 160 + 800 mg	Oral	Adult 320 + 1600 mg bd	5 days
Oral liquid	40 + 200 mg /5 mL		Child ≥ 1 month 8 mg/kg (max. 320 mg) bd <i>Dose as per trimethoprim component</i>	
Offer CMI: Take with food to reduce stomach upset. May cause fever, nausea, vomiting, diarrhoea, itch, rash or sore mouth. Avoid sun exposure. Report straight away if sore throat, fever, rash, cough, breathing difficulties, joint pain, dark urine or pale stools				
Note: If renal impairment, taking ACE inhibitor or potassium, HIV or SLE seek MO/NP advice				
Pregnancy: Do not use in the 1st trimester or in late pregnancy				
Contraindication: Severe or immediate allergic reaction to sulfonamides, megaloblastic anaemia, severe hepatic impairment, elderly				
Management of associated emergency: Consult MO/NP. See Anaphylaxis, p. 82				1,2

S ₄	Metronidazole			Extended authority ATSIHP/IHW/IPAP/RIPRN	
ATSIHP, IHW, IPAP and RN must consult MO/NP					
RIPRN may proceed					
Form	Strength	Route	Dose		Duration
Tablet	200 mg, 400 mg	Oral	Adult 400 mg bd		5 days
Oral liquid	200 mg/5 mL		Child 10 mg/kg (max. 400 mg) bd		
Offer CMI: Avoid alcohol while taking and for 24 hours after finishing the course. Take tablet with food to reduce stomach upset. Take oral liquid 1 hour before food for better absorption. May cause nausea, anorexia, abdominal pain, vomiting, diarrhoea, metallic taste, dizziness or headache					
Management of associated emergency: Consult MO/NP. See Anaphylaxis, p. 82 1,8					

S ₄	Doxycycline			Extended authority ATSIHP/IHW/IPAP/RIPRN		
ATSIHP, IHW, IPAP and RN must consult MO/NP						
RIPRN may proceed						
Form	Strength	Route	Dose		Duration	
Tablet	50 mg 100 mg	Oral	Adult 100 mg bd		5 days	
			Child ≥ 8 years			
			< 26 kg	50 mg		bd
			26–35 kg	75 mg		
> 35 kg	100 mg					
Offer CMI: Take with food or milk to reduce stomach upset. May cause nausea, vomiting, diarrhoea, epigastric burning, tooth discolouration or photosensitivity. Take with a large glass of water. Do not lie down for an hour after taking. Do not take iron, calcium, zinc or antacids within 2 hours. Avoid sun exposure						
Pregnancy: Safe in the first 18 weeks						
Contraindication: Serious allergy to tetracyclines. Taking oral retinoids. After 18 weeks of pregnancy						
Management of associated emergency: Consult MO/NP. See Anaphylaxis, p. 82 1,3						

S ₄	Ciprofloxacin			Extended authority ATSIHP/IHW/IPAP/RIPRN	
ATSIHP, IHW, IPAP and RN must consult MO/NP					
RIPRN may proceed					
Form	Strength	Route	Dose		Duration
Tablet	250 mg 500 mg	Oral	Child < 8 years 12.5 mg/kg (max. 500 mg) bd		5 days
Offer CMI: Take 1 hour before, or 2 hours after meals. Drink plenty of fluids. Do not have dairy products, zinc, iron or calcium within 2 hours of taking as reduces absorption. Avoid sun exposure. May cause dizziness or faintness, rash, itch, nausea, vomiting, abdominal pain or indigestion. Stop taking if any tenderness, inflammation or develop numbness or tingling in toes. Can cause severe diarrhoea (colitis) due to <i>C. difficile</i>					
Note: If renal impairment, epilepsy seek MO/NP advice. There is no liquid for children. Disperse one 250 mg tablet in 5 mL water to make approximate concentration of 50 mg/mL. As it has a bitter taste, follow dose with flavoured drink eg juice					
Contraindication: Serious allergy to quinolones, peripheral neuropathy					
Management of associated emergency: Consult MO/NP. See Anaphylaxis, p. 82 1,6,7					

5. Follow up

- Follow up results of MCS if taken. If needed, modify antibiotics in consultation with MO/NP
- Advise return for review in 1–2 days +
 - monitor wound closely for signs of infection eg redness, swelling, increased pain. Infection can spread rapidly
 - immediately return if:
 - any signs of localised infection - start antibiotics if not already. Consult MO/NP if worsening
 - systemic features eg fever, malaise - **urgently consult MO/NP**

6. Referral/consultation

- Consult MO/NP as above

HMP Human (tooth-knuckle) and animal bites - adult/child

Recommend¹

- Bites often become infected. Ensure thorough cleaning, irrigation, debridement, elevation and immobilisation

1. May present with¹

- Tooth-knuckle injury - hand is lacerated by another persons teeth eg a punch in the mouth
- Human or animal bite

2. Immediate management

- Initial management as per [Acute wounds, p. 162](#)
- If bite from a bat, see [Bat bite/scratch, p. 176](#) + contact MO/NP urgently

3. Clinical assessment¹

- Get history and examine wound as per [Acute wounds, p. 162](#) +
 - how/when the bite happened. If animal, what type
 - carefully examine for:
 - deeper injuries, dead tissue, retained foreign bodies eg small teeth from animal
 - signs of infection eg fever, redness, swelling, pus, [Cellulitis, p. 306](#)
 - if human, was there any blood exposure - prophylaxis for hep B ± HIV, [p. 476](#) may be indicated
- Get past history including:
 - diabetes, alcoholic liver disease, immunocompromised
- If wound infected, take swab for MCS. See [How to take a wound swab, p. 324](#)

4. Management¹

- Offer analgesia. See [Acute pain, p. 32](#)
- Manage as per [Acute wounds, p. 162](#) +
 - irrigate/clean well and debride as needed - **important to prevent infection**
 - do not suture. Allow to heal by secondary intention. Consult MO/NP as needed for advice
 - elevate and immobilise affected limb
- Check tetanus vaccination status and give booster if indicated. See [Tetanus immunisation, p. 557](#)
- If human bite(s) consider [Domestic and family violence, p. 241](#)

- **Consult MO/NP promptly** (may order IV/oral antibiotics ± evacuation/surgical drainage) - **if any of:**
 - systemically unwell eg malaise, fever, chills, ↓, ↓↓, range of motion, pus (insert IVC + blood cultures)
 - deeper tissues, tendons or joints involved (or unsure)
 - **Open fractures**, p. 154 present/suspected
- **Otherwise, give oral antibiotics if:**
 - mild/localised wound infection **OR**
 - risk of wound infection high (**'presumptive'** treatment) ie:
 - > 8 hours delay to medical care
 - puncture wound that cannot be debrided adequately
 - is on hands, feet or face
 - diabetes, alcoholic liver disease or immunocompromised
 - cat bite

Oral antibiotics if indicated¹

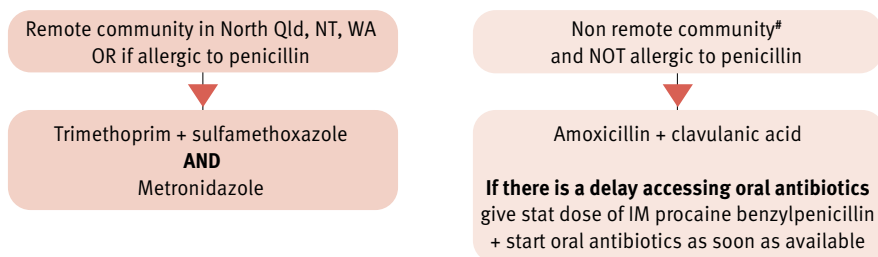

#If prior MRSA infection or MRSA suspected treat as per Remote community in North Qld, NT, WA

S4	Trimethoprim + sulfamethoxazole		Extended authority ATSIHP/IHW/IPAP/RIPRN	
ATSIHP, IHW, IPAP and RN must consult MO/NP				
RIPRN may proceed				
Form	Strength	Route	Dose	Duration
Tablet	80 + 400 mg 160 + 800 mg	Oral	Adult 160 + 800 mg bd	Presumptive 3 days Localised infection 5 days
Oral liquid	40 + 200 mg /5 mL		Child ≥ 1 month 4 mg/kg (max. 160 mg) bd <i>Dose as per trimethoprim component</i>	
Offer CMI: Take with food to reduce stomach upset. May cause fever, nausea, vomiting, diarrhoea, itch, rash or sore mouth. Avoid sun exposure. Report straight away if sore throat, fever, rash, cough, breathing difficulties, joint pain, dark urine or pale stools				
Note: If renal impairment, taking ACE inhibitor or potassium, HIV or SLE seek MO/NP advice				
Pregnancy: Do not use in the 1st trimester or in late pregnancy				
Contraindication: Severe or immediate allergic reaction to sulfonamides, megaloblastic anaemia, severe hepatic impairment, elderly				
Management of associated emergency: Consult MO/NP. See Anaphylaxis , p. 82				

1,2

S ₄	Metronidazole			Extended authority ATSIHP/IHW/IPAP/RIPRN
ATSIHP, IHW, IPAP and RN must consult MO/NP				
RIPRN may proceed				
Form	Strength	Route	Dose	Duration
Tablet	200 mg, 400 mg	Oral	Adult 400 mg bd	Presumptive 3 days
Oral liquid	200 mg/5 mL		Child 10 mg/kg (max. 400 mg) bd	Localised infection 5 days
Offer CMI: Avoid alcohol while taking and for 24 hours after finishing the course. Take tablet with food to reduce stomach upset. Take oral liquid 1 hour before food for better absorption. May cause nausea, anorexia, abdominal pain, vomiting, diarrhoea, metallic taste, dizziness or headache				
Management of associated emergency: Consult MO/NP. See Anaphylaxis, p. 82 1,3				

S ₄	Amoxicillin + clavulanic acid			Extended authority ATSIHP/IHW/IPAP/RIPRN
ATSIHP, IHW, IPAP and RN must consult MO/NP				
RIPRN may proceed				
Form	Strength	Route	Dose	Duration
Tablet	875 mg + 125 mg	Oral	Adult 875 + 125 mg bd	Presumptive 3 days Localised infection 5 days
Oral liquid	400 mg + 57 mg/5 mL		Child ≥ 2 months 22.5 mg/kg (max. 875 mg) bd <i>Dose as per amoxicillin component</i>	
Offer CMI: Take with food. May cause rash, diarrhoea, nausea or thrush. Can cause severe diarrhoea (colitis) due to <i>C. difficile</i>				
Contraindication: Severe or immediate allergic reaction to a penicillin. Be aware of cross-reactivity between penicillins, cephalosporins and carbapenems				
Management of associated emergency: Consult MO/NP. See Anaphylaxis, p. 82 1,4				

S ₄	Procaine benzylpenicillin (procaine penicillin)			Extended authority ATSIHP/IHW/IPAP/RIPRN
ATSIHP, IHW, IPAP and RN must consult MO/NP				
RIPRN may proceed				
Form	Strength	Route	Dose	Duration
Prefilled syringe	1.5 g/3.4 mL	IM	Adult 1.5 g Child 50 mg/kg (max. 1.5 g)	stat
Offer CMI: May cause diarrhoea, nausea and pain at injection site				
Contraindication: Severe or immediate allergic reaction to a penicillin. Be aware of cross-reactivity between penicillins, cephalosporins and carbapenems				
Management of associated emergency: Consult MO/NP. See Anaphylaxis, p. 82 1,5				

5. Follow up

- Follow up results of MCS if taken. If needed, modify antibiotics in consultation with MO/NP
- If antibiotics given, advise to be reviewed daily, especially tooth-knuckle injuries. If swollen, decreased range of motion, pus or not improving consult MO/NP - may need evacuation

6. Referral/consultation

- Consider referral to physiotherapist for hand therapy after tooth-knuckle injury

HMP **Bat bite/scratch** - adult/child Australian Bat Lyssavirus (ABLV), rabies

Recommend¹

- **Urgent Post-Exposure Prophylaxis (PEP)** - rabies vaccine ± human rabies immunoglobulin
- Assume all Australian bats have lyssavirus which causes rabies
- Advise to not handle bats + avoid land animals in rabies enzootic countries, including Bali, Indonesia eg dogs, cats + monkeys around temples

Background¹

- If rabies develops, it is almost always fatal

1. May present with¹

- Scratch, bite, nibble or lick from:
 - bat in Australia or overseas (alive or dead < 4 hours)²
 - land dwelling mammal in rabies enzootic country eg monkey, dog, cat

2. Immediate management¹

- Immediately + thoroughly wash bite wounds + scratches with soap and water **for at least 5 minutes**
- Apply antiseptic with anti-virus action eg Betadine®.² **Do not suture**

2. Clinical assessment^{1,2}

- Get history, including:
 - type of animal, date, time, place of exposure
 - prior rabies vaccine(s), when
 - immunocompromised
 - was the bat/animal displaying unusual behaviour; did it look sick/become sick
 - type of exposure eg:
 - minor scratch or abrasion - with or without bleeding
 - nibbling of uncovered skin
 - transdermal bites or scratches
 - contamination of mucous membrane (eg eye, nose, mouth) with saliva from licks
 - licks on broken skin

4. Management^{1,2}

- **Get URGENT advice from Public Health Unit ± MO/NP in ALL CASES who will advise + arrange PEP:**
 - see rabies vaccine/immunoglobulin indications + doses and administration advice in the *Australian immunisation handbook* <https://immunisationhandbook.health.gov.au/vaccine-preventable-diseases/rabies-and-other-lyssaviruses>
- If possible (and safe), the bat should be tested for rabies - Public Health Unit will advise²
- Check tetanus vaccination status and give booster if indicated. See [Tetanus immunisation](#), p. 557
- Consider antibiotics if indicated, as per [Bites](#), p. 173

5. Follow up

- As per MO/NP/Public Health Unit

6. Referral/consultation

- Clinical exposure + laboratory confirmed lyssavirus and rabies is notifiable ⓘ

Burns

HMP Burns - adult/child

1. May present with

- Burn eg boiling water, fire, chemical, electrical, lightning

2. Immediate management¹⁻³

- **DRSCABCD** as per [Traumatic injuries, p. 134](#)
- If safe, stop burning process. Remove from source of injury eg hot water or charred clothing:
 - if chemical burn use PPE if necessary
- Specific to burns, also check:
 - **Airway:**
 - foreign material
 - respiratory distress - stridor, hoarse voice, harsh cough, SOB, wheeze
 - soot, sputum, facial burns, black carbon around nostrils
 - if compromised insert oropharyngeal airway, [LMA, p. 56](#) or early intubation
 - maintain spinal precautions especially with explosion or electrical burns
 - **Breathing:**
 - expose chest and ensure expansion is adequate and bilateral
 - circumferential chest burns may require escharotomy. Get urgent MO/NP or Burns Unit advice
 - O₂ to maintain SpO₂ > 95% if needed
 - **Circulation:**
 - colour, HR, BP, capillary refill time (normal ≤ 2 seconds)
- **Cool burn with cool running tap water for ≥ 20 minutes** - effective up to 3 hours after injury:
 - reduce duration if burn is large or multiple trauma. May cause rapid heat loss
 - brush away any chemical first
 - if no running water, use 2 moistened towels or pads. Alternate at 15 second intervals
 - stop cooling if T < 35
 - keep remaining areas dry and warm to avoid hypothermia eg space blanket
 - if [Chemical contact burns, p. 182](#) copious amounts of water needed for at least 60 minutes, consider shower. **Note:** avoid washing chemical over unaffected skin/eyes
- **Remove jewellery and clothing as soon as possible eg rings, belts, watches:**
 - to visualise burn and to prevent ischaemic necrosis of digits
- **Get rapid history:**
 - how, when and with what were they burnt
 - any first aid, what and for how long
- **Assess** (according to tables/graphics on following pages):
 - **pain + offer analgesia.** See [Acute pain, p. 32](#). Consider IV morphine if severe pain
 - **total body surface area % (TBSA) of burn.** Use 'Rule of nines' or the NSW Trauma App https://aci.health.nsw.gov.au/networks/itim/about_itim/trauma-app
 - **burn depth**
 - **criteria to contact Burns Unit** for early advice ± transfer. **Send photos**
 - weight (if possible)

3. Clinical assessment

Rule of Nines to assess total body surface area % (TBSA)¹⁻⁴

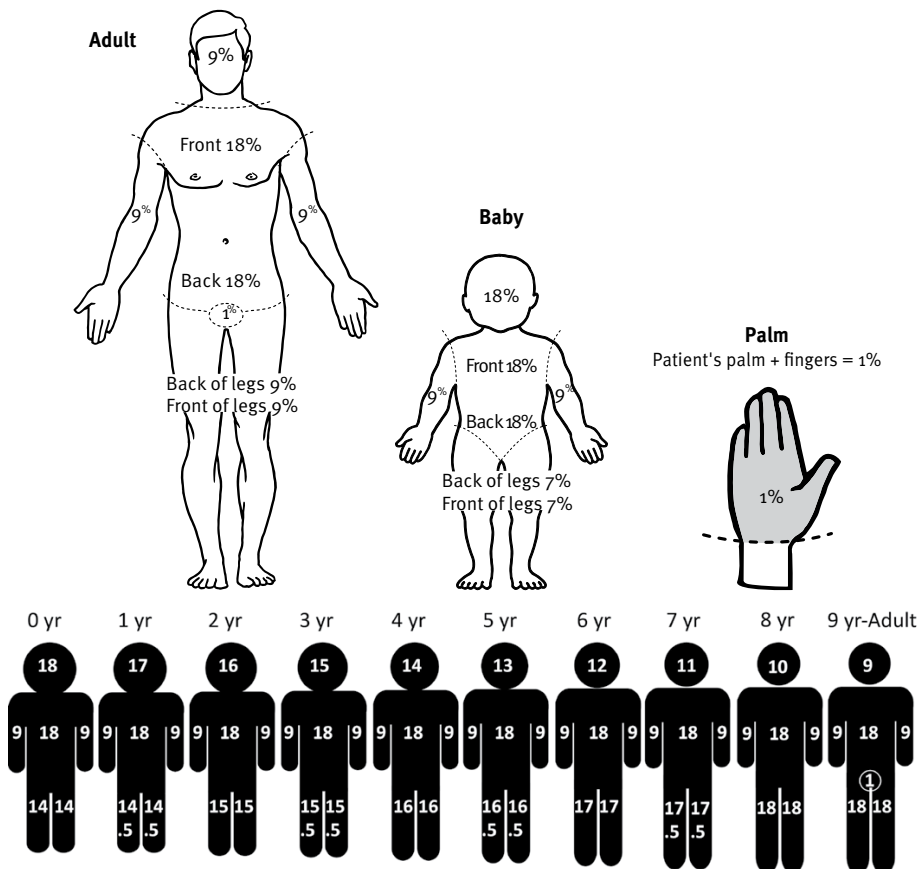

Reproduced with permission from the Agency for Clinical Innovation, NSW

Assess burn depth¹

Depth	Epidermal	Superficial mid-dermal	Mid-dermal	Deep-dermal	Full thickness
Colour	<ul style="list-style-type: none"> Red Warm to touch 	<ul style="list-style-type: none"> Pink 	<ul style="list-style-type: none"> Dark pink 	<ul style="list-style-type: none"> Pale pink Blotchy red 	<ul style="list-style-type: none"> White Charred
Capillary refill time	<ul style="list-style-type: none"> < 2 seconds 	<ul style="list-style-type: none"> Slower 	<ul style="list-style-type: none"> Sluggish > 2 seconds 	<ul style="list-style-type: none"> Sluggish to absent 	<ul style="list-style-type: none"> None
Sensation	<ul style="list-style-type: none"> Painful 	<ul style="list-style-type: none"> Very painful Raw, sensitive 	<ul style="list-style-type: none"> Painful 	<ul style="list-style-type: none"> Decreased sensation 	<ul style="list-style-type: none"> Nil
Blisters	<ul style="list-style-type: none"> None 	<ul style="list-style-type: none"> Yes 	<ul style="list-style-type: none"> Present 	<ul style="list-style-type: none"> Large, rupture within hours 	<ul style="list-style-type: none"> No blistering

Criteria to contact Burns Unit¹⁻⁴

- > 10% TBSA adults
 - > 5% TBSA in children
 - Full thickness > 5% TBSA
 - Pre-existing illness
 - Associated major trauma
 - Non-accidental burn
 - Inhalation burn injury
 - Electrical burns
 - Chemical burns
 - Pregnant
 - Young children or elderly
 - Burns to face, hands, feet, genitalia, perineum, major joints or circumferential limb or chest
- **Qld Adult Burns Centre RBWH** and page Burns Registrar on 07 3646 8111
 - **Qld Children's Hospital Brisbane** contact **CATCH** on 13 22824
 - **Townsville University Hospital** for all North Qld children with < 50% TBSA and page Paediatric Surgeon on 07 4433 1111
 - Contact local Burns Unit if outside of Qld

4. Management¹⁻³

- Treat as **severe burn** if:
 - **child < 18 months** with > 10% TBSA burns
 - **child > 18 months** with > 15% TBSA burns
 - **adult** with > 20% TBSA burn
 - inhalation injury or compromised breathing
 - high voltage electrical injury
- Otherwise go to [Minor burns, p. 181](#) for ongoing management
- For additional management of a **minor burn** caused by a chemical, see [Chemical contact burns, p. 182](#)

Severe burn

- Contact MO/NP or RSQ for urgent evacuation
- **Circumferential burns:**
 - escharotomy may be required if distal to burn:
 - capillary refill is sluggish or absent
 - pulse is weak or absent
 - skin is cool to touch
 - consult Burns Unit
- **Monitor vital signs:**
 - be alert to respirations < 10 or > 20
- **Insert IVC x 2 or Intraosseous, p. 57**
 - burns are wet and slippery. Consider suturing IVC in situ or secure with bandage
 - insert through burn if necessary. Remove within 24 hours
- **Take bloods:¹**
 - FBC, UE, CK, LFT, BGL, group and hold, coagulation studies
 - lipase, carboxyhaemoglobin
 - consider drug and alcohol screen

- **Start fluid resuscitation:**
 - fluid resuscitation of inhalation burns may cause swelling of the airway - contact Burns Unit first
 - for adult and child - IV Hartmann's using Parkland's formula:
 - **3–4 mL IV fluid x %TBSA x kg/24 hours¹⁻³**
 - 1/2 in the first 8 hours post injury then
 - 1/2 over next 16 hours
 - additional **maintenance fluids** are required if < 16 years. Discuss with MO/NP or Burns Unit
- **Insert IDC and measure output hourly:¹⁻³**
 - urine output should be:
 - **adult 0.5 mL/kg/hour**
 - **child 1 mL/kg/hour**
 - if output:
 - < 0.5 mL/kg/hour - increase IV fluids by 1/3 of current IV fluid amount
 - > 1 mL/hour for adult or > 2 mL/kg/hour for child - decrease IV fluids by 1/3 of current IV fluid
- **Insert nasogastric tube if child receiving fluid resuscitation**
- **Wound care prior to evacuation:**
 - clean with sodium chloride 0.9% or chlorhexidine 0.1%
 - remove small loose skin/blisters
 - use cling wrap to cover burns:
 - lay longways over burns
 - this is a sufficient dressing for < 8 hours
 - use paraffin based dressings for face
- **Assess for and manage other injuries.** See secondary survey in [Traumatic injuries, p. 134](#)
- Check tetanus vaccination status and give booster if indicated. See [Tetanus immunisation, p. 557](#)

5. Follow up

- As per MO/NP and Burns Unit
- Consider non-accidental injury (if injury/presentation inconsistent with history) eg self inflicted injury, elder abuse, [Domestic and family violence, p. 241](#), + consider [Child protection, p. 551](#):
 - + contact police

6. Referral/consultation

- Consult MO/NP as above

HMP Minor burns - adult/child

1. May present with^{1,3}

- An epidermal or superficial dermal burn:
 - < 10% TBSA in adult
 - < 5% TBSA in child
- Blistered, painful, pale pink/red, raw, brisk capillary return
- From scald, minor flame or other heat contact

2. Immediate management

- Cool with running water for at least 20 minutes within the first 3 hours of injury

3. Clinical assessment

- Assess as per [Burns, p. 177](#)

4. Management^{1,3}

- Offer analgesia. See [Acute pain, p. 32](#)
- Clean with sodium chloride 0.9% or clean water and mild soap
- Remove all foreign matter, loose and non viable skin and tissue
- Debride blisters if > 2.5 cm or over joints
- Dress according to **Minor burn dressing** table below:
 - unless concerned about infection, dress wounds **as infrequently as possible** to allow healing
 - expect exudate in the first 72 hours. Use absorbent gauze or foam
 - switch to a low adhesive paraffin dressing once risk of infection is low
 - ensure dressing is secure and non-constrictive
 - elevate affected area as appropriate

Minor burn dressing ^{1,2,5}		
	Epidermal burn	Superficial mid-dermal burn
Character	<ul style="list-style-type: none"> • Painful • Epidermis damaged/intact • Red 	<ul style="list-style-type: none"> • Blistered • Painful, raw • Pale pink, red • Brisk capillary return within burn margin
Dressing	<ul style="list-style-type: none"> • Soothing moisturisers • Vaseline • Paraffin gauze 	<ul style="list-style-type: none"> • Absorbent dressings • Foams • Alginates • Silicone dressings <p>If contaminated:</p> <ul style="list-style-type: none"> • Silver products • Silver sulfadiazine cream dressing where adherence to regimen is a concern

S ₄	Silver sulfadiazine			Extended authority ATSIHP/IHW/IPAP/RIPRN
ATSIHP, IHW, IPAP and RN must consult MO/NP				
RIPRN may proceed				
Form	Strength	Route	Dose	Duration
Cream	1%	Topical	Adult and child > 2 months Apply a 3–5 mm thick layer	3 days max. after burn
Offer CMI: May cause burning, itch or rash. Avoid contact with eyes				
Note: Discard tube 7 days after opening. 1 tube per person				
Contraindication: Premature infants, infants < 2 months, or in last month of pregnancy				
Management of associated emergency: Consult MO/NP. See Anaphylaxis, p. 82				4

5. Follow up

- Review daily initially or sooner if:
 - fever
 - increased pain, redness, swelling or purulent exudate
- Consult MO/NP if wound(s):
 - become infected
 - are unhealed or poorly granulating > 14 days

6. Referral/consultation

- Consult MO/NP as above

HMP Chemical contact burns - adult/child

Hydrofluoric acid, cement, phosphorus, bitumen, petrol, other acids + alkalis

Recommend

- Contact Poisons Information Centre (PIC) ☎ 13 11 26 (24 hours) or local Burns Unit. See [Burns, p. 177](#)

Background

- Can be a fluid, powder or gas
- **Alkalis** causing burns:
 - drain cleaners, oven cleaners, denture cleaners, household bleach, detergents and cleaners
 - cement, pool chlorine
- **Acids** causing burns:
 - stain removers and cleaners, battery and rust proofing fluids
 - fertilisers, swimming pool and laboratory chemicals
 - electroplating, glass etching and light bulbs chemicals

1. May present with¹

- History of exposure to chemical agent
- Visible burn or excoriation that may appear superficial
- Pain due to tissue destruction and toxicity
- Hypotension/shock

2. Immediate management^{1,2}

- Strict use of PPE
- Remove contaminated clothing
- First brush away all dry chemical powders eg cement, lime, phosphorous
- Then prolonged irrigation with water \geq 20 minutes. Consider shower
- Offer analgesia. See [Acute pain, p. 32](#)

3. Clinical assessment

- Assess as per [Burns, p. 177](#)
- Do vital signs
- Get history, including:
 - how, when and with what were they burnt
 - any first aid, what and for how long
 - identify **active ingredients** if possible
 - if hydrofluoric acid determine:
 - concentration %
 - onset of symptoms:
 - within an hour for $>$ 40% concentration
 - within 24 hours $<$ 10% concentration
 - if bitumen determine:
 - if any circumferential hardened bitumen is causing constriction of limb

4. Management

- If a **severe burn** continue to manage as per [Burns, p. 177](#)
- Consult MO/NP
- Additional chemical burn management information below

Hydrofluoric acid¹⁻³

- Extremely toxic
- Maintain PPE standards
- **To neutralise the acid** consult MO/NP or PIC who may order:
 - **calcium gluconate:**
 - IV for systemic toxicity
 - topically for dermal exposures applied liberally to site using:
 - 2.5% gel **OR**
 - 1 ampoule 2.2 mmol/10 mL **mixed with** 30 g water soluble gel (eg KY Jelly®)
 - nebulised in O₂ or air for inhalational exposures using:
 - 1 ampoule 2.2 mmol/10 mL - **dilute** 1 mL with 3 mL of sodium chloride 0.9%
- If i-STAT available, check potassium, calcium and magnesium
- Consult MO/NP for evacuation/hospitalisation
- Observe for 6 hours after exposure
- Asymptomatic patients with a normal serum calcium concentration can be discharged
- Also see [Poisoning and overdose, p. 211](#)

Bitumen burns^{4,5}

- For severe bitumen burns refer to the Burns Unit. See [Burns, p. 177](#)
- Do not remove large bitumen areas. Cooled bitumen will form a waterproof, sterile layer which

- prevents the burn from drying out
- In consultation with the Burns Unit:
 - if hardened circumferential bitumen is causing constriction, use a hydrophobic solvent to soften and split the bitumen eg orange oil (De-Solv-It®) or petroleum jelly
 - small bitumen areas can be gently removed with the same solvent
 - any remaining bitumen will naturally fall off in time due to re-epithelialisation
- Do not** remove bitumen from the eye. Evacuate for specialist assessment and management
- If not evacuated, see [Minor burns, p. 181](#) for dressing options

Cement, phosphorous, petrol¹

- Remove visible particles
- If dressing is required see [Minor burns, p. 181](#)
- Consider evacuation if symptomatic

Unscheduled	Calcium gluconate			Prescribing guide
RIPRN and RN only. Must be ordered by an MO				
Form	Strength	Route	Dose	Duration
Injection	2.2 mmol/10 mL	IV	Adult 30 mL Child 0.6 mL/kg (max. 30 mL)	stat Inject slowly over 5–10 minutes in a large peripheral vein
Offer CMI: To neutralise effects of hydrofluoric acid				
Note: High risk medicine and is rapidly fatal in overdose. Extravasation can cause tissue necrosis				
Contraindication: Subcut and IM route				
Management of associated emergency: Consult MO/NP. See Anaphylaxis, p. 82				

3,6

5. Follow up

- Review daily
- According to MO/NP or Burns Unit recommendations

6. Referral/consultation

- As above

Environmental emergencies

HMP Decompression illness (DCI/bends) - adult/child

Recommend

- All divers who become unwell should be discussed with a diving medicine physician urgently¹
- If transport by air is required, movement at lowest possible safe altitude or in pressurised cabin is recommended

Background

- DCI/bends is nitrogen bubble formation in the blood/tissues due to the changes in pressure while diving²
- 90% of illness after diving are dive related³
- Also see *Assessing potential diving related illness* https://qheps.health.qld.gov.au/__data/assets/pdf_file/0026/335294/sw210.pdf. If outside of Qld, see local protocol

1. May present with

- Consider in anyone feeling unwell after diving¹

2. Immediate management⁴

- **DRSABCD**
- Do vital signs + give 100% O₂ via non-rebreather mask at 15 L/minute **regardless of SpO₂**
- If early-onset DCI is suspected ie ≤ 30 minutes of surfacing:
 - lay the patient flat if possible
 - if conscious + difficulty breathing when flat, place in a comfortable position
- Urgently contact MO/NP for all unwell divers regardless of time since last dive¹

3. Clinical assessment

- **Ask about symptoms:**⁴
 - joint/muscle pain in limbs or torso - most common symptom³
 - numbness/tingling
 - extreme fatigue
 - dizziness/vertigo
 - muscle weakness in arm(s) ± legs
 - headache, nausea, vomiting, passing urine normally³
- **Get dive(s) details, including:**⁴
 - time of surfacing + onset of symptoms
 - any first aid + response⁴
 - number of recent dives + duration, bottom time, depth, decompression stops, speed of ascent, surface interval
- Ask about any alcohol in last 24 hours + other causes of dehydration
- Relevant past history eg hole in the heart^{2,3}
- Do physical examination, including:
 - GCS, p. 562 + neurological observations. Any confusion
 - check joints - any ↓ range of motion³
 - balance + coordination

- skin - mottled/blotchy rash⁴
- Also check for associated barotrauma eg pneumothorax, ruptured eardrum:²
 - listen to chest - equal breath sounds + chest wall movement
 - eardrums - any redness, bulging, retraction or blood

4. Management

- MO/NP will advise further management eg IDC, rehydrate with oral or IV fluids⁴
 - **note:** IV glucose containing solutions **should NOT be given**¹
- Monitor closely until evacuation +
 - keep flat + during evacuation if possible¹
 - continue 100% O₂ ± air breaks as per MO/NP
 - keep warm, not hot - avoid sun exposure, unnecessary activity + excess clothing^{2,4}
- Offer ibuprofen. See [Acute pain, p. 32](#)

5. Follow up

- As per MO/NP/specialist

6. Referral/consultation

- Hyperbaric Medicine Unit:
 - Townsville University Hospital ☎ 07 4433 1111
 - Royal Brisbane + Women's Hospital ☎ 07 3646 8111
- Divers Emergency Service ☎ 1800 088 200, to speak directly to hyperbaric doctor

Hypothermia - adult/child

Recommend^{1,2}

- Prolonged CPR until normothermic or until MO/NP advise to stop - complete recovery is possible
- Do not rewarm in bath

Background^{1,2}

- Hypothermia is when a body's core T falls below 35

1. May present with^{1,2}

- Following exposure to cold ±
 - shivering, ↑ muscle tone
 - pale, cool skin
 - impaired coordination, slurred speech
 - apathy/confusion/loss of consciousness
 - slow RR

2. Immediate management¹

- DRSABCD
- **Handle GENTLY to prevent arrhythmias:**¹
 - the hypothermic heart is very sensitive to movement. Rough handling may precipitate arrhythmias including VF or asystole
 - **note:** most arrhythmias resolve spontaneously with rewarming
- Remove wet clothing + dry patient, place in warm, wind free environment + allow to shiver

- Do vital signs + BGL
- Start continuous cardiac monitoring
- Start rewarming eg warm blankets, heating pads + warming devices if available
- Contact MO/NP, **urgently if T < 32, slow irregular HR, ↓ BP or ↓ LOC**
- Give warm sweetened drinks (not alcohol) if fully conscious^{1,2}

3. Clinical assessment¹

- Ask about:
 - length of exposure, time since
 - any first aid + witnesses
- If not exposure related, look for other causes eg:
 - drug intoxication/stimulants
 - recent neurological events, illnesses, infections
 - underlying endocrine disorders eg diabetes
- Do physical examination while limiting exposure to prevent further heat loss, including:
 - ECG
 - look for other injuries + any muscle stiffness
 - check extremities for exposure injuries - any numbness, pain, do they look pale + waxy
 - i-STAT - UE

4. Management¹

- Consult MO/NP who may advise:
 - IV glucose 10% - start rate at: **adult** 100 mL/hour, **child** 3–5 mL/kg/hour:
 - then ↑ rate until BGL 5.5–11
 - warmed sodium chloride 0.9% if fluid resuscitation required - give cautiously as per MO/NP
 - take bloods - coagulation studies
 - evacuation/hospitalisation
- Monitor closely until evacuation:
 - vitals signs + continuous cardiac monitoring
 - keep warm
- If mild hypothermia T 32–35 + patient spontaneously rewarms once removed from the cold:¹
 - discuss discharge with MO/NP

5. Follow up

- As per MO/NP

6. Referral/consultation

- As above

HMP Hyperthermia - adult/child

Heat exhaustion, heat stroke

Recommend

- Paracetamol, aspirin + ibuprofen are ineffective + should not be used to actively cool¹

Background¹

- Heat stroke is life-threatening. Core T > 40 + can result in organ failure
- Heat exhaustion is usually mild. Associated with exercise + dehydration. May be difficult to distinguish from heat stroke

1. May present with²

- Hot, sweaty + breathless ±
 - dizziness, faintness
 - nausea, vomiting or diarrhoea
 - signs of shock eg ↓ LOC, pale skin
 - dry skin - lack of sweating is a serious sign

2. Immediate management²

- **DRSABCD**
- Lie the patient in a cool place or in the shade + loosen/remove excess clothing
- Rapidly assess + do vital signs
- **Start cooling + contact MO/NP, urgently if T ≥ 40** - may indicate heat stroke¹
- **If > 5 years** immerse whole body from neck down in cold as possible water eg bath for 15 minutes
 - if no bath, do combination of:
 - wet with cold/cool water, under shower/hose
 - apply ice packs to groin, armpits, cheeks, palms + soles
 - repeatedly moisten the skin with a moist cloth + fan continuously
- **If < 5 years** cool in lukewarm bath or repeatedly moisten the skin with a moist cloth + fan continuously
- Give cool/cold water to drink if fully conscious²
- If shivering - risk of heat gain:¹
 - insert IVC + give IV midazolam, **note:** small dose of only 0.5–1 mg for an adult

S ₄	Midazolam			Extended authority RIPRN
RN must consult MO/NP				
RIPRN may proceed				
Form	Strength	Route	Dose	Duration
Injection	5 mg/5 mL	IV	Adult and child 0.01 mg/kg	stat MO/NP may order further doses at 5 minutely intervals until shivering is suppressed
Offer CMI: May cause drowsiness or respiratory depression				
Note: Caution calculating and measuring low dose. Monitor for sedation + respiratory depression				
Management of associated emergency: Consult MO/NP. See Anaphylaxis, p. 82				

3. Clinical assessment

- Ask about:^{1,2}
 - any signs of infection, recent illnesses - consider [Sepsis, p. 64](#)
 - recent activity/exercise in hot conditions
 - if child have they been left in a car¹
 - inadequate fluid intake
 - illicit drugs or medications which affect heat regulation - consider drug associated hyperthermia eg anticholinergics, stimulants, SSRIs/MAOIs, antipsychotics¹
 - any muscle pain
- Do physical examination, including:¹
 - BGL
 - ECG + continuous cardiac monitoring
 - listen to chest - any crackles, wheeze
 - look for petechial haemorrhages, bruising
 - palpate muscles - any tenderness
 - urinalysis for leucocytes, nitrites, blood + note colour of urine
 - i-STAT - UE¹

4. Management

- **If T < 40 + symptoms resolve ≤ 30 minutes, likely heat exhaustion:¹**
 - discuss discharge with MO/NP +
 - advise on prevention eg keep cool, wear light coloured, loose-fitting clothing, drink plenty of fluids on hot days² + delay return to activity/sports ≥ 48 hours¹
- **If likely heat stroke, MO/NP may further advise:**
 - IV fluids, give cautiously based on clinical parameters eg urine output + BP
 - bloods - LFT, coagulation studies¹
 - stop cooling if T about 38 to avoid overcooling¹
 - insert IDC
 - evacuation/hospitalisation
- If drug associated hyperthermia - MO/NP may order:³
 - cold IV fluids at maintenance rate, rarely > 20 mL/kg is required
 - **note:** IV fluid stored in a standard refrigerator is approx. 4°C
- Monitor closely until evacuation - vital signs, airway + urine output

5. Follow up

- As per MO/NP

6. Referral/consultation

- Consider child safety reporting for children being left in a car. See [Child protection, p. 551](#)

Ears, nose and throat (ENT) emergencies

HMP Nose bleed/epistaxis - adult/child

Background¹

- 95% of nose bleeds are anterior and are usually managed by simple compression of nose

1. May present with

- Nose bleed

2. Immediate management^{1,2}

ALERT suspect [Button battery](#), [p. 80](#) insertion or ingestion in child with blood around nostrils. If lodged in the oesophagus, it can burn a hole through to the aorta causing catastrophic haemorrhage

- **DRSABCD**
- **If active bleeding + SHOCKED²** (major obvious epistaxis in process) (cool, ↑ HR, CRT > 2 seconds):
 - urgently consult MO/NP + urgent evacuation
 - insert [Anterior nasal pack](#), [p. 191](#) eg Rapid Rhino®
 - IVC x 2
 - take bloods - FBC, group and hold, coagulation studies²
 - start IV sodium chloride 0.9% 10–20 mL/kg
 - MO/NP may order IV tranexamic acid.¹ See drug box in [Traumatic injuries](#), [p. 134](#)
 - **If not controlled**, MO/NP may advise:
 - [Posterior nasal pack](#), [p. 192](#) (take out anterior pack first)
 - ± remove pack and trying other nostril
 - ± Rapid Rhino® to both nostrils
- **If active bleeding + NOT shocked:²**
 - apply continuous pressure on the lower third of nose with thumb and forefinger for 5–10 minutes¹
 - sit upright, lean forward
 - breathe through mouth + spit blood out rather than swallowing
 - **if not stopped after 10–15 minutes:^{1,2}**
 - reapply pressure and reassess (incorrect pressure most common cause of continued bleeding)
 - spray lidocaine (lignocaine) + phenylephrine into nostrils
 - insert absorbable pack eg Kaltostat®
 - continue applying pressure
 - **if still bleeding:**
 - remove Kaltostat® and insert [Anterior nasal pack](#), [p. 191](#) eg Rapid Rhino®
 - urgently consult MO/NP
 - continue to manage as per ‘if active bleeding + shocked’ above

3. Clinical assessment^{1,2}

- Do vital signs
- Get history, including:
 - onset, duration and severity of bleeding
 - prior nose bleeds - when, how often, severity, treatment
 - **red flags** for tumour eg nasal blockage, facial pain/swelling, headaches, deep toothache, teenage male¹

- **risk factors** for nose bleed:
 - nose or facial trauma, nose picking, CPAP use
 - prior nasal surgery
 - intranasal medicine or drug use
 - bleeding disorders (or family history of), easy bruising
 - kidney/liver disease, hypertension
 - taking anticoagulants/antiplatelets eg NSAIDs

4. Management

- If bleeding stops with compression alone, patient can go home with first aid advice:
 - return if bleeding re-starts and unable to control at home with compression
 - if risk factors/red flags present or recurrent bleed(s), advise to see MO/NP at next clinic
- If anterior nasal pack inserted, MO/NP may advise:^{1,2}
 - evacuation/hospitalisation OR home with pack in situ + give **Nasal pack discharge advice** (remove in 24–72 hours)
 - ± antibiotics

Anterior nasal pack insertion - only to 1 nostril

Rapid Rhino® - easiest and least painful + most comfortable for patient^{1,3}

- Use size 4.5 cm (< 8 years), 5.5 cm (all ages) or larger size for posterior pack
- PPE + get good light source + sit patient up if possible
- Soak in sterile water for a FULL 30 seconds
- Spray lidocaine (lignocaine) + phenylephrine on the Rapid Rhino^{®4}
- Insert in straight direction along floor of nasal cavity, until blue indicator is past the nares
- Use a 20 mL syringe to inflate device with AIR. Stop inflation when the pilot cuff becomes rounded and feels firm when squeezed
- Reassess after 15–20 minutes. Re-inflate as needed to ensure proper pressure
- Tape to patient's cheek
- **See instructions + video** at <https://rapidrhino.com/rapid-rhino-product-usage-instructions/>

Other nasal pack eg Merocel^{®5}

- Coat with water soluble gel + grasp string with fingers
- Gently and quickly insert along the floor of the nasal cavity until the string reaches the nose
- If packing has not expanded in 30 seconds, irrigate with 10 mL sodium chloride 0.9%
- Tape the string to the nose and trim ends
- Moisten with saline prior to removal

Nasal pack discharge advice¹

- May have symptoms of a cold while in place eg blocked nose, ↓ smell, facial pressure, headaches, nasal drainage, tearing from eyes
- Try not to blow nose. Sneeze with open mouth
- To avoid ↑ blood flow to the nose and risk of further bleeding - avoid straining, lifting > 5 kg, strenuous exercise, bending over + sleep with head slightly elevated
- Avoid aspirin and ibuprofen (may ↑ bleeding). Take paracetamol if needed for pain
- Keep pack moist by spraying with sodium chloride 0.9%
- Return immediately if bleeding starts (nose or mouth), fever, ↑ pain, vision changes, SOB, loss of colour of skin around nose, swelling of face, skin rash

Posterior nasal pack insertion - only to 1 nostril

- MO/NP may advise if anterior packing does not work, or catastrophic haemorrhage
- **Use Rapid Rhino®** in larger size than normal - in attempt to control posterior and anterior bleeding (follow instructions as per anterior nasal packing)
- OR, use Foley® urine catheter - **get further advice if trauma/suspected base of skull fracture**^{1,2}

Foley® catheter² - note Rapid Rhino® preferred

- PPE + get good light source + sit patient up if possible
- Have suction available + assistant to apply as you insert catheter
- Spray nasal passage with lidocaine (lignocaine) + phenylephrine - it will be painful
- Lubricate tip of catheter (sterile lubricant)
- Measure half way point between nasal septum and tragus of ear
- Insert in straight direction along floor of nasal cavity towards ear lobe - to half way point
- Keep mouth open
- You **MUST be able to see the TIP** of catheter in back of throat **BEFORE inflating balloon**:
 - inflate with 3 mL air and pull catheter forward until it 'catches' in the back of the nose
 - then inflate with up to 10 mL air, stopping when it gets too uncomfortable
- Get assistant to maintain firm traction while you pack anterior nostril eg with a Rapid Rhino®
- Secure catheter at nostril to prevent it slipping backwards eg with tubing clamp/clip
- Place wad of gauze between clamp and patients nose to prevent pressure necrosis
- Secure catheter to patients face with tape

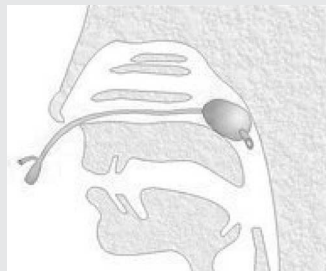

- If posterior pack inserted, will need urgent evacuation + close observation + antibiotics:
 - at risk of airway obstruction if Foley® dislodges or placed inappropriately

S2	Lidocaine (lignocaine) + phenylephrine		Extended authority ATSIHP/IHW/IPAP	
ATSIHP, IHW, IPAP, RIPRN and RN may proceed				
Form	Strength	Route	Dose	Duration
Spray	Lidocaine (lignocaine) 5% + Phenylephrine 0.5%	Intranasal	Adult and child ≥ 12 years up to 5 sprays Child ≥ 2 years 2–4 years 1 spray 4–8 years 2 sprays 8–12 years 3 sprays	stat
Offer CMI: May cause transient burning and stinging. Numbness of tongue or mouth; risk of trauma from hot drinks or biting. Do not eat or drink for two hours after. Bitter taste for 1–2 minutes				
Contraindication: Pregnancy and child < 2 years				
Management of associated emergency: Consult MO/NP. See Anaphylaxis, p. 82				

6

5. Follow up

- If nasal pack in situ and not evacuated, review next day or sooner if any concerns:
 - remove pack as advised by MO/NP

6. Referral/consultation

- MO/NP may consider ENT referral as appropriate

Traumatic rupture of eardrum - adult/child

1. May present with^{1,2}

- Hearing loss, tinnitus (ringing in ears), earache
- + history of:
 - blow to ear eg slap, fall from water skis, diving
 - rapid change in ear pressure eg air travel, scuba diving, blast/explosion
 - object poked in ear eg cotton tipped applicator

2. Immediate management Not applicable

3. Clinical assessment¹

- Ask about:
 - circumstances + mechanism of injury eg any water exposure
 - date/time of injury + when first noticed symptoms
 - vertigo/dizziness, hearing loss, tinnitus, light-headedness, other symptoms/injuries
 - prior history of ear infections/problems
- If blow to head, assess for [Head injuries, p. 143](#) including base of skull fracture
- Do vital signs
- Do otoscopy - note location + size of perforation, any discharge/pus:
 - do NOT syringe ears with water or remove any blood in canal - can delay healing
- Check hearing using audiometry (if possible)
- If hearing loss, use tuning fork test to determine type (if able):^{1,3}
 - activate fork by striking firmly on your bent elbow. Place vibrating fork firmly on the midpoint of the patient's skull, or central forehead. Is sound heard better in normal ear (sensorineural hearing loss), or ear with ruptured eardrum (conductive hearing loss)

4. Management

- If vertigo/dizziness **seek urgent medical advice ± evacuation**
- Consult MO/NP who may advise:
 - ciprofloxacin ear drops if 'dirty' injury (eg in water) or discharge/infection¹ ± ENT and audiology referral
- Advise to keep ear dry until healed.¹ Use Blu Tack® or cotton wool in ear with Vaseline® over top while showering. Avoid swimming
- Most perforations will heal without treatment¹ within 2 months⁴
- If related to assault/[Domestic and family violence, p. 241](#), offer support/referral as per local policies. Also consider [Child protection, p. 551](#)

5. Follow up

- Advise to be reviewed in 2–3 days, see MO/NP at next clinic + review 2 weekly until healed if asymptomatic, or sooner if concerned eg infection

6. Referral/consultation

- MO/NP may refer to ENT specialist if not healed after 3 months^{1,5,6}

Foreign body in ear or nose - adult/child

1. May present with^{1,2}

- Foreign body (FB) in ear or nose eg insect, bead, pebble, plastic toy, food

Symptoms suggesting possible FB in ear/nose of child

Ear	Nose
<ul style="list-style-type: none"> - ear pain, hearing loss, discharge (pus or blood) - ear fullness, hiccups or cough that won't stop - tinnitus (ringing in ear) 	<ul style="list-style-type: none"> - nasal occlusion or bleeding nose - malodorous, pus or blood stained discharge - facial swelling or pain

2. Immediate management^{1,2}

- Urgently consult MO/NP for ENT referral if:
 - suspected [Button battery](#), p. 80 or paired magnets (in nose) - **time critical emergency**:
 - **urgent removal needed**. If suspected, but not visualised, x-ray needed to rule out. If no on-site x-ray arrange urgent evacuation
 - bleeding or airway issues if FB to nose²

ALERT button batteries require urgent removal to prevent necrosis of surrounding tissue

3. Clinical assessment^{1,2}

- Get history and examine ears/nose
- Identify exact location, shape and composition of FB
- If possible, get assistant to help, especially if child (in addition to caregiver)

4. Management^{1,2}

- **Do NOT attempt to remove if any of below:**
 - FB not easily seen **OR** is deep in the ear/nose
 - large **OR** impacted FB
 - child moving/noncompliant - risk of trauma, pushing FB further in, or aspiration
 - paired magnets or magnet and metallic object across septum of nose ie in each nostril
 - penetrating or hooked FB
 - if any of above, consult MO/NP for evacuation/referral to ENT
- **Otherwise, attempt to remove FB from ear or nose ONCE** - regardless of method:
 - if unsuccessful or not comfortable attempting, consult MO/NP

Removing FB from NOSE²

Small, smooth or spherical objects	<ul style="list-style-type: none"> • Self blow/exhale - if child old enough to cooperate eg > 3 years, encourage to blow nose while occluding the nostril opposite to the FB • Parents' kiss - ask parent/caregiver to seal the child's mouth with their mouth, while occluding the unaffected nostril. Then give a short sharp puff of air • Suction - only try if FB visible and not 'lodged'. Use micro suction tube. Form a solid seal between tube and object. Be careful not to push FB up nose • Magnet device - (if available) for metal object - insert gently until clicks onto object. Be careful not to push FB up nose
Soft, irregular, small object	<ul style="list-style-type: none"> • Forceps - only use if FB visible and looks easy to grasp. Avoid repeated grasping attempts as may push FB in further
Other objects	<ul style="list-style-type: none"> • Consult MO/NP

Removing FB from EAR ¹	
Soft, irregular, small object	<ul style="list-style-type: none"> • Forceps - only use if FB visible and looks easy to grasp. Avoid repeated grasping attempts as may push FB in further
Insect or small inorganic object	<ul style="list-style-type: none"> • Gentle irrigation - if insect, put 2–3 drops of cooking oil into ear to kill first. Irrigate with warm water using a cut 14/16 G cannula (needle removed) with a 30 or 60 mL syringe. Direct stream along upper back area of canal. Repeat as needed • Do NOT irrigate if suspected perforated eardrum, grommets, button battery, vegetable matter or expandable FB
Smooth/spherical mobile objects	<ul style="list-style-type: none"> • Gentle suction - only try if FB visible and not 'lodged.' Use micro suction tube to form a solid seal between tube and object • Magnet device - (if available) for metal object - insert gently until clicks onto object
Other objects	<ul style="list-style-type: none"> • Consult MO/NP

- **Post removal:**
 - look for other FBs patient may have inserted + for any trauma/infection:^{1,2}
 - if significant trauma to ear canal consult MO/NP who may order dexamethasone + framycetin + gramicidin (eg Otodex®, Sofradex®) or ciprofloxacin ear drops ± ENT referral¹
 - treat concurrent **Otitis externa**, p. 532 if present¹
- Give education around safe storage of small objects eg button batteries, marbles, coins, balloons. Ensure toys for play are appropriate for age^{1,2}

5. Follow up

- **Ear FB removed** - advise to be reviewed:¹
 - if any symptoms arise ie hearing loss, discharge, marked pain, facial nerve paralysis or dizziness/feeling off balance. Consult MO/NP ± ENT referral
 - if ear drops given, in 2–3 days
- **Nose FB removed** - advise to be reviewed:²
 - if any symptoms arise ie fever, purulent discharge, nose bleed, facial pain or swelling. Consult MO/NP ± ENT referral

6. Referral/consultation

- As above

Gastrointestinal emergencies

HMP Acute abdominal pain - adult/child

Recommend

- **Always consider:**

- [Ectopic pregnancy, p. 371](#) in all females of reproductive age with abdominal pain ± bleeding
- [PID, p. 462](#) in sexually active females, particularly if < 25 years, with new onset of pelvic pain
- [Testicular torsion, p. 209](#) and check testes in males with abdominal pain + male infants with inconsolable crying

1. May present with

- Abdominal pain

2. Immediate management

- Do vital signs
- If signs of shock - ↑HR, ↑RR, ↓BP, ↓LOC:
 - contact MO/NP urgently
 - start treatment for [Shock, p. 62](#)
- Screen for [Sepsis, p. 64](#)
- If severe pain:
 - insert IVC x 2, do rapid assessment
- Offer analgesia ± antiemetic. See [Acute pain, p. 32](#), [Nausea and vomiting, p. 40](#):
 - **note:** analgesia does not mask physical signs/hinder diagnosis^{1,2}

3. Clinical assessment³

- It is not necessary to make a definitive diagnosis. It is more important to recognise cases which are significant
- Ask about the pain:
 - **Site** - where is it
 - **Onset:**
 - gradual, rapid or sudden
 - continuous or intermittent
 - what were they doing when it started
 - **Character** - sharp, dull, burning, stabbing, cramp like, crushing, tingling
 - **Radiate** - anywhere eg shoulder tip, back
 - **Alleviating factors** - eg sitting up, medicine, relief by moving about eg renal colic, or from lying very still eg peritonitis
 - **Timing:**
 - when did it first begin, duration
 - have they had it before, when, what happened
 - any increase in severity
 - **Exacerbating factors** - does anything make it worse eg movement
 - **Severity:**
 - does it interfere with sleep or normal activities
 - mild, moderate or severe (scale 1–10)

- Also ask about:^{1,4}
 - **associated symptoms** - eg fever, SOB, recent weight loss, changes in appetite, nausea, vomiting - any blood, bile or green vomit
 - **bowels** - any diarrhoea, constipation, blood, black stools/melaena, time of last motion, passing wind¹
 - **urine** - dysuria, frequency, urgency, haematuria
 - **vaginal** - bleeding, discharge. **Note:** abnormal discharge may indicate [PID](#), p. 462
- **Get past history**, including:¹
 - recent trauma
 - medical + surgical history
 - smoking, alcohol + other drugs
 - medications + family history
 - menstrual history in females - last period, was it normal, are periods regular, any contraception³
- **Do physical examination**, including:^{1,2}
 - urinalysis
 - pregnancy test if female of reproductive age - **if +ve go to Ectopic pregnancy**, p. 371
 - ECG¹ + BGL
 - bloods/i-STAT including lactate
 - listen to chest - any wheeze, crackles:
 - **note:** pneumonia and [ACS](#), p. 107 can present with abdominal pain
 - [Hydration assessment](#) - adult, p. 200 or [child](#), p. 535
 - check for:
 - pallor, jaundice
 - enlarged lymph nodes
 - **Red flags**

Red flags - if any contact MO/NP urgently

- Pain radiating to the back + palpable pulsatile mass⁵
 - Localised tenderness, distension
 - Guarding - ↑ muscle tightness in response to palpation³ or board like rigidity
 - Rebound tenderness - pain when pressure is applied + then released suddenly³
- **Do abdominal examination:**¹
 - **look** for:
 - symmetry, shape eg distended or sunken
 - surgical scars, bruises, distended veins, hernias
 - signs of non-accidental injury⁶
 - **listen** for bowel sounds - absent, decreased or hyperactive
 - normal are low pitched + gurgling 2–5/minute.² Hyperactive/high pitched suggests [Bowel obstruction](#), p. 205
 - **palpate** - start lightly, away from site of pain + move through the 9 areas. Follow with deep palpation:^{1,2}
 - also palpate kidneys - with one hand underneath + one hand above (below rib line), gently push down
 - check testes in males
 - **percuss (tap)** all four quadrants to check for dullness
 - Rectal examination - may be indicated if suspected [Upper GI bleeding](#), p. 203

Abdominal quadrants

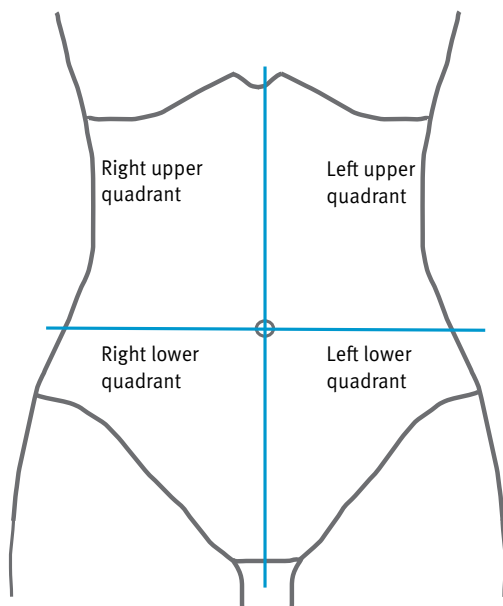

4. Management

- Consult MO/NP in all cases of moderate to severe pain, or if cause not known
- MO/NP may order:
 - chest + abdominal x-ray
 - urgent evacuation/hospitalisation
 - antibiotics, IDC, nasogastric tube
 - nil by mouth

5. Follow up

- If not evacuated, advise patient to be reviewed next day, or sooner if:¹
 - pain persists > 24 hours, worsens or changes from generalised to localised, or
 - worsening symptoms or new symptoms develop eg vomiting, fever
 - if any of the above, contact MO/NP

6. Referral/consultation

- As above

Abdominal pain causes

Right hypochondriac

- Gall bladder - biliary colic or cholecystitis⁷
- Hepatitis
- Pneumonia
- Liver abscess/tumour - rare

Epigastric

- Myocardial infarction
- Gastritis or gastric/duodenal ulcer⁷
- Pancreatitis⁷
- Ruptured aortic aneurysm

Left hypochondriac

- Pneumonia
- Pancreatitis
- Ruptured spleen

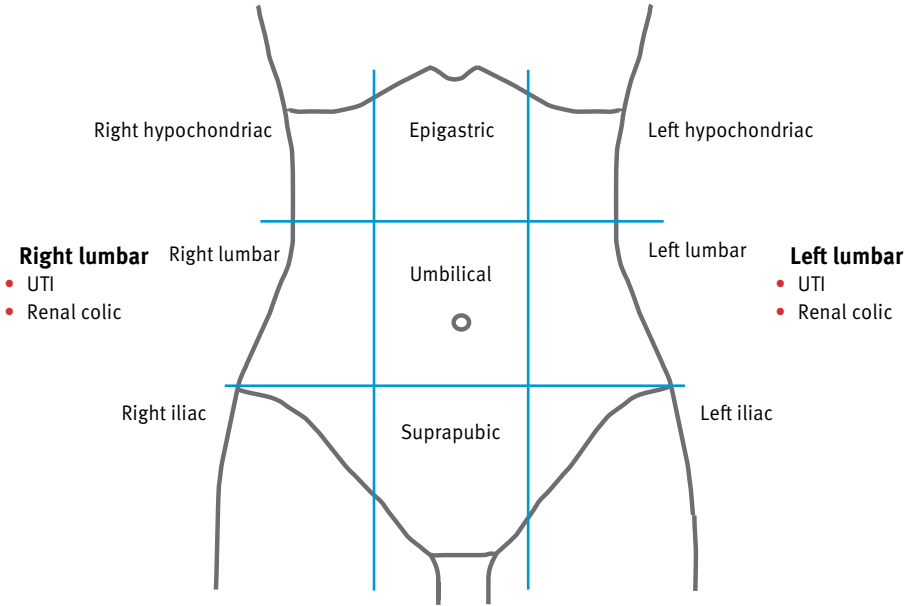

Right lumbar

- UTI
- Renal colic

Left lumbar

- UTI
- Renal colic

Right iliac

- Appendicitis⁶
- Ectopic pregnancy (unilateral)⁴
- Ovarian cyst⁴
- PID (bilateral)⁴
- Strangulated hernia (usually men)
- Testicular torsion

Umbilical

- Strangulated umbilical hernia
- Ruptured aortic aneurysm⁵
- Gastroenteritis
- Small bowel obstruction
- Inflammatory bowel disease
- Early appendicitis (then moves to right iliac)⁷

Left iliac

- Diverticulitis
- Ectopic pregnancy (unilateral)⁷
- Ovarian cyst⁷
- PID (bilateral)⁴
- Strangulated hernia (usually men)
- Testicular torsion

Suprapubic

- Ectopic pregnancy⁴
- Testicular torsion
- Miscarriage⁴
- UTI
- Large bowel obstruction
- Acute retention of urine
- Uterine fibroid complication
- PID⁴

Gastroenteritis/dehydration - adult

Diarrhoea ± vomiting

Recommend¹

- Rehydration is the most important aspect of management ie with oral rehydration solution (ORS)

Background¹

- Most acute diarrhoea is viral, self-limiting and resolves without specific treatment
- Antibiotics are of no benefit in most cases and may exacerbate diarrhoea¹

Related topics

[Giardiasis, p. 538](#)

[Gastroenteritis - child, p. 535](#)

[Nausea and vomiting, p. 40](#)

[DKA, p. 89](#)

1. May present with¹

- Sudden onset of diarrhoea ± vomiting, fever or abdominal pain
- Lethargy, dehydration

2. Immediate management

- Do vital signs + **Hydration assessment¹**
- **If severe dehydration:**
 - contact MO/NP urgently
 - continue to manage as per [Shock, p. 62](#)

Hydration assessment ¹			
	Mild	Moderate	Severe
Level of consciousness	alert	slightly lethargic	altered
Thirst	mild	moderate	intense
Oral mucous membranes	slightly dry	dry	parched, with wrinkled tongue
Sternal skin turgor		↓	marked ↓
Eyes		normal	sunken
RR	normal	normal or ↑	normal or ↑
HR		↑	
BP		mild ↓ or postural ↓	severe ↓ with cold extremities
Urine output	normal or ↓	↓	significant ↓ or no output

3. Clinical assessment

- Get history, including:¹
 - gastrointestinal symptoms:
 - date/time of onset, frequency, is there blood ± mucous in stools, bile stained or green vomit, location and severity of abdominal pain
 - fever, rash, headache
 - known illness in contacts
 - recent overseas travel¹
- Do physical examination, including:²
 - BGL - if ↑ consider [DKA, p. 89](#)
 - i-STAT - UE, lactate

- urinalysis - ketones
- [abdominal examination, p. 197](#)
- Do stool MCS if:¹
 - diarrhoea > 7 days
 - severe symptoms eg blood in stools, high fever, ↑ HR, abdominal tenderness or severe pain^{1,2}
 - immunocompromised (stool MCS + parasites + viral pathogens)
 - recent overseas travel

4. Management

- Consult MO/NP if:
 - vomiting and unable to tolerate oral fluids² - IV fluids may be required
 - severe symptoms
 - immunocompromised or elderly¹
- If mild to moderate dehydration:¹
 - give ORS, even if intermittent vomiting
 - **note:** if ORS is not available, use 1/2 level teaspoon of salt + 6 level teaspoons of sugar in 1 L of clean drinking water
 - aim for 2–3 L over 24 hours. Frequent small volumes may be better tolerated eg 50 mL every 15–30 minutes
 - avoid fatty or sugary foods and excessive intake of soft drinks, sports/energy drinks, cordials and fruit juice. If used they should be diluted
- Offer antiemetic if needed. See [Nausea and vomiting, p. 40](#)
- Once tolerating/responding to ORS, advise patient to return to normal diet¹
- If patient prepares or serves food - advise to avoid handling food until they have not had any diarrhoea or vomiting for 48 hours

5. Follow up¹

- Advise patient to return if symptoms worsen or develop severe vomiting, abdominal cramps or blood in stools:
 - contact MO/NP
- Review stool MCS results

6. Referral/consultation³

- Notify Public Health Unit if ≥ 2 cases of diarrhoea ± vomiting in the same location or single case in a food handler ①

HMP Gastritis - adult

Background

- Inflammation of the gastric mucosa commonly caused from *Helicobacter pylori* infection, use of NSAID, or alcohol¹

1. May present with

- Epigastric pain or discomfort ± nausea, vomiting, heartburn²

2. Immediate management

- Do vital signs
- If signs of shock - ↑HR, ↑RR, ↓BP, ↓LOC:
 - contact MO/NP urgently + see [Shock, p. 62](#)
- Assess as per [Chest pain assessment, p. 103](#) + see [ACS, p. 107](#)
- Offer analgesia ± antiemetic. See [Acute pain, p. 32](#), [Nausea and vomiting, p. 40](#)

3. Clinical assessment

- Do not jump to conclusions as to the cause of the epigastric pain in a person who drinks alcohol²
- Do NOT use medication cocktail eg pink lady, Shaw's cocktail, to assist in ruling out a cardiac cause³
- Also ask about:
 - pain - onset + duration
 - is it accompanied by nausea, vomiting and heartburn²
 - any blood in vomit² ± melaena, go to [Upper GI bleeding, p. 203](#)
 - recent heavy alcohol intake¹
 - are they taking NSAID, aspirin^{1,2}
 - previous episodes - when, any treatment
 - recent weight loss, difficulty or painful swallowing²
- Get past history of heart disease, GORD, peptic ulcer disease, abdominal surgery¹
- Do physical examination, including [abdominal examination, p. 197](#) +
 - ECG + BGL⁴
 - bloods/i-STAT - lactate

4. Management

- **Contact MO/NP urgently** if intense boring pain that radiates to the back⁵
- Consult MO/NP, who may advise:
 - IV pantoprazole ± IV thiamine if alcohol related^{1,5}
 - bloods for *Helicobacter pylori*²
 - evacuation/hospitalisation ± referral for endoscopy⁶

5. Follow up

- Advise to return if symptoms ↑↑ or new symptoms eg blood in vomit - contact MO/NP urgently. Otherwise advise to see MO/NP at next clinic

6. Referral/consultation

- As above

HMP Upper gastrointestinal bleeding - adult/child

Vomiting blood

Background

- Usually caused secondary to peptic ulcer disease, erosions, oesophagitis or oesophageal varices¹

1. May present with

- Vomiting blood or dark vomit with 'coffee grounds' ± melaena, pain¹

2. Immediate management

- Do vital signs
- Insert IVC x 2
- If signs of shock - ↑HR, ↑RR, ↓BP, ↓LOC or large active bleed:
 - contact MO/NP urgently + see [Shock, p. 62](#)

ALERT suspect [Button battery, p. 80](#) in all children with upper GI bleed. A button battery lodged in the oesophagus can burn a hole through to the aorta

3. Clinical assessment

- Get rapid history, including:
 - is blood dark, bright or coffee grounds, amount + duration
 - melaena or any fresh blood in stools
 - repeated retching/vomiting prior to bleeding - may indicate oesophageal tear¹
 - previous episodes²
 - history of liver failure, ischaemic heart disease, renal failure, peptic ulcer, oesophageal varices^{1,2}
 - alcohol misuse²
 - ask if taking - aspirin, NSAID, anticoagulants, corticosteroids, iron supplements²
- Do physical examination, including [abdominal examination, p. 197](#) +
 - ECG²
 - i-STAT - lactate, baseline Hb (HemoCue if available)
 - bloods - FBC, UE, INR, LFT, cross match

4. Management

- Consult MO/NP urgently, who may advise:
 - IV fluids
 - IV pantoprazole ± IV thiamine if alcohol misuse^{2,3}
 - evacuation/hospitalisation for urgent endoscopy/surgery³
- Monitor vital signs closely until evacuation, keep nil by mouth

5. Follow up

- As advised by MO/NP

6. Referral/consultation

- As above

HMP Rectal bleeding - adult/child

1. May present with

- Blood mixed in/with stool or blood leaking from the rectum¹

2. Immediate management

- Do vital signs
- If signs of shock - ↑HR, ↑RR, ↓BP, ↓LOC or blood loss is heavy or continuing:
 - contact MO/NP urgently + see [Shock, p. 62](#)

ALERT suspect [Button battery, p. 80](#) in all children with melaena or bloody discharge from rectum

3. Clinical assessment

- Do not attribute rectal bleeding to haemorrhoids unless more serious causes have been excluded
- Get history, including:
 - onset and duration of bleeding +
 - colour of blood - bright or dark
 - does it coat the stool or is it mixed with the stool¹
 - associated with straining or passing hard stool²
 - past history of haemorrhoids
 - any change in bowel habits eg constipation, diarrhoea, black or maroon stools^{1,3}
 - abdominal pain, rectal pain or itch, recent weight loss
 - bowel disease eg diverticular, Crohn's disease, colon/rectal cancer^{1,4}
 - recent removal of polyps¹
 - recent trauma to rectum, including sexual trauma
 - are they taking aspirin, NSAID¹
- Do physical examination, including [abdominal examination, p. 197](#) +
 - check perianal area for - haemorrhoids (not always visible), skin tags, anal fissures, haematoma^{1,3}
- Consider vaginal bleeding as source, especially in older patient¹

4. Management

- Consult MO/NP who may advise:
 - rectal examination, bloods, investigations for serious causes eg cancer
 - topical medication²
 - evacuation/hospitalisation
- If haemorrhoids, advise patient to:²
 - avoid straining and constipation
 - adequate intake of fibre and fluids
 - respond to the urge to open bowels (rather than holding in). Do not try to initiate a bowel action without the urge

5. Follow up

- If not evacuated, advise to be reviewed at next MO/NP clinic. Earlier if concerned/bleeding returns

6. Referral/consultation

- As above

HMP Bowel obstruction - adult/child

Recommend

- Metoclopramide is contraindicated¹

1. May present with²⁻⁴

- Abdominal pain ± bloating, nausea, vomiting, fever

2. Immediate management²

- Do vital signs
- Screen for [Sepsis, p. 64](#)
- Offer analgesia (not oral). See [Acute pain, p. 32](#)
- Insert IVC + start IV sodium chloride 0.9% - then as ordered by MO/NP

3. Clinical assessment

- See [Abdominal pain, p. 196](#) to guide assessment
- Suspect bowel obstruction if:
 - pain:
 - intermittent, colicky, continuous²
 - any distension, is it getting worse
 - nausea, vomiting, inability to pass wind or stool²
 - changes to bowel habits, recent weight loss²
 - rectal bleeding, crampy rectal pain²
 - ask about possibility of foreign body ingestion as cause of obstruction²⁻⁴
- Get past history:
 - abdominal or pelvic surgery, bowel obstruction, hernias²⁻⁴
 - recent abdominal trauma³⁻⁴
 - inflammatory bowel disease eg Crohn's disease, diverticulitis³⁻⁴
 - are they taking - opioids, NSAIDs, corticosteroids, chemotherapy³⁻⁴
- Do physical examination, including:²
 - ECG
 - BGL
 - bloods/i-STAT - UE, lactate, FBC, LFT, lipase²
 - [abdominal examination, p. 197](#) check for:
 - tenderness, guarding, rigidity, masses
 - hyperactive/high pitched bowel sounds

4. Management

- If infant consider [Intussusception, p. 545](#)
- Consult MO/NP urgently, who may advise:
 - urgent evacuation for CT scan/surgery
 - IV antibiotics
 - x-ray
 - IDC
 - nasogastric tube²
- Keep nil by mouth

- Monitor closely until evacuation:
 - vital signs
 - urine output

5. Follow up

- As per MO/NP

6. Referral/consultation

- As above

Genitourinary emergencies

HMP Renal colic - adult

Background

- Pain can be caused by kidney stone passage or an obstruction in the urinary tract¹

1. May present with

- Severe one sided flank pain radiating to the groin:^{2,3}
 - usually episodic, typically lasting 20–60 minutes + may not completely resolve before next wave³
 - very distressed and unable to find a comfortable position³
- Nausea + vomiting, sweating, looks unwell²
- ± haematuria²

2. Immediate management

- Do vital signs
- Give oral ibuprofen or IM ketorolac ± antiemetic. See [Acute pain, p. 32](#), [Nausea and vomiting, p. 40](#)
- If severe pain, consider giving a single dose of IV morphine¹ until NSAID works^{2,4}

3. Clinical assessment

- See [Abdominal pain, p. 196](#) to guide assessment
- Get history, including:⁴
 - nausea and vomiting, fever
 - urinary symptoms eg dysuria, frequency, urgency
 - past history of kidney stones, previous episodes, renal impairment
- Do physical examination, including:
 - [Hydration assessment - adult, p. 200](#)
 - urinalysis to confirm haematuria + MSU for MCS if nitrites or leucocytes⁴
 - pregnancy test if female of reproductive age⁴

4. Management

- **Contact MO/NP urgently if:**
 - a pulsatile abdominal mass and ↓BP - a ruptured AAA can mimic renal colic⁴
 - fever, pyuria (eg cloudy urine) or significant tenderness - suggests infected obstructed kidney⁴
- Main aim of treatment is analgesia + IV fluids if significantly dehydrated.⁴ **Note:** most stones pass spontaneously < 1 month⁵
- Consult MO/NP, who may advise:⁴
 - eFAST USS (if skilled/available) or evacuation for CT scan/IVP
 - IV fluids
 - or consider sending home if able to tolerate oral fluids and adequate pain relief with oral NSAID⁴ with follow up at next MO/NP clinic

S4	Ketorolac			Extended authority
ATSIHP, IHW and RN must consult MO/NP				
RIPRN may proceed				
Form	Strength	Route	Dose	Duration
Injection	10 mg/mL	IM	10 mg	stat Inject slowly into a large muscle. Apply pressure for 15–30 seconds after injecting to minimise local reactions Do not give repeat doses (potential serious adverse effects)
Offer CMI: May cause pain at injection site, itching, sweating or purpura				
Note: Use with caution in the elderly, asthma, hypertension, coagulation disorders or other NSAID use				
Pregnancy: May increase rate of miscarriage. Seek specialist advice for use in the 2nd half of pregnancy; do not use during the last few days before expected birth				
Contraindication: Dehydration, hypovolaemia, probenecid use, GI bleeding, renal or hepatic impairment, heart failure. Allergic to aspirin or NSAIDs				
Management of associated emergency: Consult MO/NP. See Anaphylaxis, p. 82				
				1,6,7

5. Follow up

- If not evacuated, advise to:
 - be reviewed if develops fever, vomiting or pain returns - contact MO/NP
 - see MO/NP at next clinic ± urology referral

6. Referral/consultation

- As above

HMP Acute retention of urine - adult

Background

- Predominantly affects men. The most common causes are obstruction eg enlarged prostate. Can also be caused from infection, constipation, inflammation or injury¹

1. May present with

- Inability to urinate or empty bladder effectively + suprapubic pain, bloating, urgency, distress^{1,2}

2. Immediate management^{2,3}

- Do vital signs
- Screen for [Sepsis, p. 64](#)
- Offer analgesia. See [Acute pain, p. 32](#)

3. Clinical assessment

- See [Abdominal pain, p. 196](#) to guide assessment
- Also ask about:
 - worsening urinary symptoms eg nocturia, frequency, urgency, weak stream, dribbling^{1,3}
 - systemic symptoms eg T \geq 38, chills, sweats³
 - previous episodes
 - prostate or bladder problems¹
 - prolapse of the bladder, rectum, or uterus - in females¹
 - recent pelvic trauma, STI, IDC²
 - nausea, vomiting, constipation²
 - medications eg anticholinergic, antidepressants^{1,2}
- Do physical examination, including:
 - abdomen for distension and palpable bladder²
 - urinalysis if possible + MSU for MCS² or collect from IDC if advised to insert
 - bladder scan if available

4. Management

- Contact MO/NP, who may advise:
 - insert IDC:¹
 - if likely difficult catheterisation, urgent evacuation for urological review/suprapubic catheter¹
 - DO NOT use force to push IDC through the obstructed urethra
 - bloods \pm cultures, antibiotics³
- Monitor urine output. MO/NP may advise IDC be removed or left in situ

5. Follow up

- If not evacuated, advise to be reviewed next day and consult MO/NP
- Advise to see next MO/NP clinic

6. Referral/consultation

- As above

HMP Testicular/scrotal pain - adult/child

Testicular torsion

Recommend

- Testicular torsion is an emergency. Surgery is required ≤ 6 hours to avoid permanent harm, even if the pain has been present > 6 hours¹

1. May present with

- Pain in the testes/scrotum \pm swelling, abdominal pain^{1,2}
- **Note:** if recent testicular injury assume testicular torsion until proven otherwise

2. Immediate management

- **Rapidly assess** against table below:¹
 - the presence or absence of a single sign cannot exclude testicular torsion +
 - keep in mind boys may be reluctant to volunteer symptoms due to embarrassment and reluctance to be examined
- **Contact MO/NP urgently in all cases of testicular/scrotal pain**
- Offer analgesia \pm antiemetic. See [Acute pain, p. 32](#), [Nausea and vomiting, p. 40](#)
- Do vital signs

Assessment of testicular pain^{1,2}

	Testicular torsion	Epididymo-orchitis (EDO)
Onset and location	<ul style="list-style-type: none"> • Sudden onset of severe unilateral scrotal pain • May be gradual, mainly in the iliac fossa \pm history of minor trauma • Intermittent testicular pain - can result from intermittent torsion/ spontaneous detorsion 	<ul style="list-style-type: none"> • Gradual onset of pain and swelling over a few days² • Usually one side
Other symptoms	<ul style="list-style-type: none"> • Nausea, vomiting, tachycardia¹ • \pm fever 	<ul style="list-style-type: none"> • Dysuria, frequency, smelly urine¹
Examination Note: to check cremasteric reflex - pinch or stroke the skin of the upper thigh. The testis on the same side should elevate via contraction of the muscle	<ul style="list-style-type: none"> • Testis - abnormal position, horizontal lie on standing and high riding¹ • Scrotal skin changes - red or darkening^{1,2} • Tender to palpate • Thickened spermatic cord¹ • Absent cremasteric reflex¹ 	<ul style="list-style-type: none"> • Red, hot, swollen testis in normal position • Tender epididymis (tubular structure found at back of testes, running in a sagittal plane) • Intact cremasteric reflex^{1,2}
Also check	<ul style="list-style-type: none"> • Urinalysis - leucocytes does not exclude testicular torsion¹ • Lump in groin of child with acute abdominal or inguinal pain can be torsion of undescended testis but may be mistaken for swollen lymph node or abscess¹ 	<ul style="list-style-type: none"> • Urinalysis - NAD does not exclude EDO¹ • Risk factors eg recent urethral surgery, history of viral infection eg mumps, sexually active³

3. Clinical assessment

- See **Immediate management**

4. Management

- Contact MO/NP urgently in all cases who will arrange urgent evacuation + referral to surgical team:
 - even if the pain has been present > 6 hours
- Monitor vital signs closely and re-examine scrotum if patient deteriorates⁴
- Keep nil by mouth¹
- USS and bloods should not delay surgical review¹

5. Follow up

- As per MO/NP/surgical team

6. Referral/consultation

- As above

Poisoning and overdose

HMP Poisoning and overdose - adult/child

Toxicology assessment

Recommend¹

- **Always contact the Poisons Information Centre (PIC) for any poisoning or overdose ☎ 13 11 26 (24 hours) or, for satellite phone use only (07) 4763 7617**
- Provide the following information:
 - name and spelling of the toxin or drug(s), and if able, the active ingredients and send photo
 - patient age, weight, sex, comorbidities, medical history, medication history
 - unintentional or deliberate intent of poisoning
 - time since exposure, route, dose eg amount swallowed, licked container lid
 - actions taken by the patient, parents or carers
 - clinical effects since exposure
 - vital signs
 - results from any investigations

1. May present with¹⁻⁴

- Confusion, drowsiness, loss of consciousness, fitting
- Respiratory failure
- Hyperthermia, hypothermia
- Nausea, vomiting, diarrhoea
- Hypotension, hypertension, bradycardia, tachycardia, arrhythmias
- Conscious and fully orientated
- A history suggestive of deliberate or accidental poisoning or drug taking

2. Immediate management¹⁻⁴

- **DRSABCD.** Resuscitation if required. See [BLS, p. 46](#)
- Contact MO/NP urgently
- Insert IVC x 2 if required
- If contamination suspected, remove all clothes and shower with soap and water. Use PPE
- If patient is confused or withdrawn, strange, aggressive or displaying acutely disturbed behaviour ensure safety of self and others. See [Mental health emergency, p. 336](#)
- **Note:** do not undertake any gastrointestinal decontamination (eg activated charcoal) until a full [Toxicology assessment, p. 212](#) has been completed

3. Clinical assessment¹⁻⁴

- Do a [Toxicology assessment, p. 212](#)
- Do vital signs +
 - SpO₂
 - BGL
 - i-STAT/bloods
 - [GCS/AVPU, p. 562](#)
 - ECG and continuous cardiac monitoring
 - temperature. **Note:** hyperthermia can be life-threatening

- Take the following bloods for every patient and send during evacuation:
 - serum electrolyte (bicarbonate and potassium) concentrations
 - renal function, LFT, FBC
 - venous blood gases
 - serum paracetamol concentration

Toxicology assessment ¹	
Agent	<ul style="list-style-type: none"> • Name of product(s), its active ingredients, manufacturer • Look for container if possible • Ask relatives or witnesses • Ask if alcohol was taken concurrently. This can affect the toxicity of other exposures • Ask if paracetamol or other over-the-counter products were taken
Route of exposure	<ul style="list-style-type: none"> • Oral, topical, eye, inhaled, injected
Dose	<ul style="list-style-type: none"> • How much was taken ie estimate maximal dose on number of remaining tablets/liquid subtracted from total packet/bottle • Always consider the worst-case scenario • Was substance diluted eg insecticides • For a frequent substance user: <ul style="list-style-type: none"> – frequency – duration and pattern of use – time and amount of last use – average daily consumption
Time of exposure	<ul style="list-style-type: none"> • Exact time
Intent of exposure	<ul style="list-style-type: none"> • Accidental or deliberate • If deliberate also see Mental health emergency, p. 336
Action since exposure	<ul style="list-style-type: none"> • Skin washed, eyes irrigated, self induced vomiting, drank milk etc
Patient factors	<ul style="list-style-type: none"> • Age, weight, gender, comorbidities - including mental health issues
Clinical course	<ul style="list-style-type: none"> • What symptoms have occurred since exposure to poison/medicine
Clinical status	<ul style="list-style-type: none"> • BP, HR, RR, T, SpO₂, BGL, conscious state

4. Management¹⁻⁴

- Consult MO/NP urgently
- Following stabilisation of the patient, good supportive care and monitoring is sufficient most of the time

For significant proven or suspected poisoning or overdose the patient will likely require:

- Intubation and ventilation
- IV fluids to maintain blood pressure ± inotropes on advice of MO/NP or PIC
- Unless contraindicated, activated charcoal typically within 2 hours of ingestion. See table below
- Evacuation
- ± extra **Toxin specific management considerations**. See table below

Activated charcoal

- Given on MO/NP or PIC advice only
- Only give if the patient can self-administer without assistance
- Patients at risk of becoming drowsy, unconscious or fitting require intubation prior to nasogastric or orogastric administration
- Rarely indicated in children

ECG monitoring

- Regular monitoring of ECG for:
 - QRS widening:
 - QRS > 120 msecs (0.12 seconds) is considered pathological
 - associated with ingestions of eg tricyclic antidepressants, antihistamines, antiarrhythmics
 - QT prolongation:
 - can be associated with torsades de pointes (abnormal heart rhythm that can be fatal)
 - associated with ingestions of eg antiarrhythmics, antidepressants, antihistamines, antibiotics and antipsychotics
- Send rhythm strips to MO/NP or toxicologist and be guided by their recommendations

Toxin specific management considerations	
Poison or toxic agent	Extra management considerations after: <ul style="list-style-type: none"> – contact with Poisons Information Centre (PIC) 13 11 26 – MO/NP consultation – Toxicology assessment
Alcohol (ethanol) Beer, wine, spirits (also see Toxic alcohol)	<ul style="list-style-type: none"> • Death is usually due to inhalation of vomit or respiratory depression • Activated charcoal is not indicated • Symptomatic treatment and supportive care
Angiotensin Converting Enzyme Inhibitor (ACEI) Captopril, enalapril, fosinopril, lisinopril, perindopril, quinapril, ramipril and trandolapril	<ul style="list-style-type: none"> • Symptomatic treatment and supportive care
Angiotensin II Receptor Blocker (ARB) Candesartan, eprosartan, irbesartan, losartan, olmesartan, telmisartan and valsartan	<ul style="list-style-type: none"> • Symptomatic treatment and supportive care
Anticonvulsants (benzodiazepines) Alprazolam, bromazepam, clobazam, clonazepam, diazepam, flunitrazepam, nitrazepam, oxazepam, temazepam, midazolam and lorazepam	<ul style="list-style-type: none"> • Symptomatic treatment and supportive care • Can cause CNS depression, rarely coma

Toxin specific management considerations	
Poison or toxic agent	Extra management considerations after: <ul style="list-style-type: none"> – contact with Poisons Information Centre (PIC) 13 11 26 – MO/NP consultation – Toxicology assessment
Anticonvulsants (others) Carbamazepine, lamotrigine, levetiracetam, oxcarbazepine, phenobarbital (phenobarbitone), pentobarbital, primidone, pregabalin, gabapentin, phenytoin, sodium valproate, thiopental, tiagabine and topiramate	<ul style="list-style-type: none"> • Symptomatic treatment and supportive care • Can cause CNS depression, rarely coma • Consider midazolam for persistent seizures. See Fitting, p. 86
Antihistamines (sedating) Alimemazine, chlorpheniramine, cyclizine, brompheniramine, cyproheptadine, diphenhydramine, dexchlorpheniramine, doxylamine, pheniramine and promethazine	<ul style="list-style-type: none"> • Regular observations • Diazepam for sedation of agitated patient. See Mental health emergency, p. 336 • IDC for urinary retention
Antipsychotics Amisulpride, aripiprazole, brexpiprazole, chlorpromazine, clozapine, haloperidol, lurasidone, olanzapine, paliperidone, pericyazine, quetiapine, risperidone and ziprasidone	<ul style="list-style-type: none"> • May require noradrenaline. Avoid adrenaline (epinephrine) • IV benzatropine to manage abnormal involuntary movements • Cardiac monitoring for QT prolongation
Arsenic Arsenic gas, inorganic arsenic oxides and salts, organic arsenic	<ul style="list-style-type: none"> • Evacuate for urgent assessment, decontamination and chelation therapy
Aspirin and other salicylates Oil of wintergreen, teething gels	<ul style="list-style-type: none"> • Consider sodium bicarbonate to increase the urinary elimination of salicylates • Consider glucose for coma or seizures, not anticonvulsants
Baclofen	<ul style="list-style-type: none"> • Consider midazolam for persistent seizures or delirium. See Fitting, p. 86
Barbiturates Phenobarbitone, primidone, pentobarbitone and thiopental	<ul style="list-style-type: none"> • CNS depression is common in large ingestion • Symptomatic treatment and supportive care
Benzodiazepines	<ul style="list-style-type: none"> • See Anticonvulsants (benzodiazepines)
Beta-blockers Propranolol, sotalol, atenolol, bisoprolol, carvedilol, labetalol, metoprolol, nebivolol and oxprenolol	<ul style="list-style-type: none"> • Propranolol and sotalol are the most toxic beta blockers • Consider atropine for bradycardia (on MO/NP or PIC instruction) • Symptomatic treatment and supportive care

Toxin specific management considerations

Poison or toxic agent	Extra management considerations after: <ul style="list-style-type: none"> – contact with Poisons Information Centre (PIC) 13 11 26 – MO/NP consultation – Toxicology assessment
Button battery	<ul style="list-style-type: none"> • See Button battery, p. 80
Caffeine	<ul style="list-style-type: none"> • See Theophylline and caffeine
Calcium channel blockers Verapamil or diltiazem	<ul style="list-style-type: none"> • Consider activated charcoal for ingestions within 12 hours • Consider calcium gluconate or calcium chloride for persistent hypotension and bradycardia • For ingestions > 10 tablets PIC will discuss other decontamination options
Calcium channel blockers Amlodipine, felodipine, lercanidipine, nifedipine and nimodipine	<ul style="list-style-type: none"> • Consider activated charcoal for ingestions within last 4 hours
Carbon monoxide inhalation	<ul style="list-style-type: none"> • 15 L/minute O₂ non-rebreather mask for 6 hours • Keep at rest to minimise oxygen needs
Caustic and corrosive substances Domestic and industrial cleaning agents, oven cleaners, dishwasher detergents, acids and drain cleaners	<ul style="list-style-type: none"> • Wipe out the mouth with a cloth, then rinse with water • Nil by mouth • Offer analgesia. See Acute pain, p. 32
Chloroquine, hydroxychloroquine or quinine	<ul style="list-style-type: none"> • Consider midazolam for persistent seizures. See Fitting, p. 86
Clonidine	<ul style="list-style-type: none"> • Most ingestions result in prolonged drowsiness • Continue to monitor and provide symptomatic treatment and supportive care
Colchicine	<ul style="list-style-type: none"> • Give activated charcoal for all ingestions
Cyanide Inhalation in domestic or industrial fires, ingestion of cyanide-containing products	<ul style="list-style-type: none"> • Strict PPE precautions
Digoxin	<ul style="list-style-type: none"> • Atropine to treat bradycardia associated with hypotension • Consider digoxin immune Fab to bind and remove digoxin and treat hyperkalaemia (may be brought with retrieval team)
Essential oils Eucalyptus oil, tea tree oil and aromatherapy oils	<ul style="list-style-type: none"> • Symptomatic treatment and supportive care
Flecainide	<ul style="list-style-type: none"> • Consider sodium bicarbonate to treat ventricular arrhythmias associated with QRS widening

Toxin specific management considerations	
Poison or toxic agent	Extra management considerations after: <ul style="list-style-type: none"> – contact with Poisons Information Centre (PIC) 13 11 26 – MO/NP consultation – Toxicology assessment
Gamma-hydroxybutyrate (GHB) A drug of abuse	<ul style="list-style-type: none"> • Alternating coma and agitation is a common presentation • Symptomatic treatment and supportive care • Consider midazolam for persistent seizures. See Fitting, p. 86
Hallucinogens LSD	<ul style="list-style-type: none"> • Consider benzodiazepines for agitation and acute behavioural disturbances. See Mental health emergency, p. 336
Herbicide Chlorophenoxy	<ul style="list-style-type: none"> • Rapid cooling techniques for hyperthermia • Consider sodium bicarbonate for urinary alkalinisation • Consider potassium chloride for hypokalaemia
Herbicide Glyphosate	<ul style="list-style-type: none"> • Consider sodium bicarbonate for metabolic acidosis
Herbicide Paraquat	<ul style="list-style-type: none"> • Strict PPE precautions • Do not routinely administer O₂ • For decontamination consider: <ul style="list-style-type: none"> – activated charcoal – soil (mix with water) or – Fuller's earth (calcium montmorillonite)
Hydrocarbons Petrol, fuels and other oils eg sniffing (eg petrol, glues, marker pens, paint thinners) or chroming (eg aerosol sprays including paints)	<ul style="list-style-type: none"> • PPE precautions • Consider salbutamol MDI/NEB for bronchospasm. See Asthma, p. 95
Hydrofluoric acid Also see: <ul style="list-style-type: none"> – Chemical contact burns, p. 182 – Chemical burn to eye, p. 285 	<ul style="list-style-type: none"> • Extremely toxic. Treatment guided by PIC • For dermal exposures, remove all clothes and shower with soap and water • Analgesia for pain • Consider calcium gluconate: <ul style="list-style-type: none"> – topically for dermal exposures – IV for any metabolic, cardiovascular or CNS effects • Consider midazolam for persistent seizures. See Fitting, p. 86
Insecticides	<ul style="list-style-type: none"> • See Pesticides
Iron Ferrous fumarate, gluconate or sulfate	<ul style="list-style-type: none"> • Activated charcoal is not indicated • Desferrioxamine is indicated in patients with severe systemic toxicity

Toxin specific management considerations

Poison or toxic agent	Extra management considerations after: <ul style="list-style-type: none"> – contact with Poisons Information Centre (PIC) 13 11 26 – MO/NP consultation – Toxicology assessment
Lead Inhaled or swallowed from mining, manufacturing, paint, piping, fishing sinkers, petrol sniffing	<ul style="list-style-type: none"> • Evacuate for urgent assessment, decontamination and chelation therapy
Lithium Usually from chronic usage	<ul style="list-style-type: none"> • Activated charcoal is not indicated • Symptomatic treatment and supportive care • Consider midazolam for persistent seizures. See Fitting, p. 86
Local anaesthetics Articaine, benzocaine, bupivacaine, cinchocaine, cocaine, levobupivacaine, lidocaine (lignocaine), mepivacaine, oxybuprocaine, prilocaine, proxymetacaine, ropivacaine and tetracaine (amethocaine)	<ul style="list-style-type: none"> • QRS widening signals progression of toxicity • Treat seizures and ventricular arrhythmias associated with QRS widening with IV sodium bicarbonate • Hyperventilate by invasive or non-invasive ventilation
Metformin	<ul style="list-style-type: none"> • Causes lactic acidosis not hypoglycaemia • Consider IV sodium bicarbonate for metabolic acidosis
Methotrexate	<ul style="list-style-type: none"> • Consider calcium folinate as antidotal therapy • Brought with retrieval team
Mirtazapine	<ul style="list-style-type: none"> • Symptomatic treatment and supportive care
Monoamine oxidase inhibitors (MAOIs) Phenelzine and tranylcypromine	<ul style="list-style-type: none"> • Treat hypertension with benzodiazepines as first-line and GTN if hypertension persists • Cooling techniques for Hyperthermia, p. 188 • Consider midazolam for persistent seizures. See Fitting, p. 86
Nicotine Children who chew on cigarettes, nicotine gum, patches or drink nicotine liquid from e-cigarettes Adults on nicotine replacement therapy who continue to smoke	<ul style="list-style-type: none"> • Consider atropine for excessive secretions, bradycardia and bronchoconstriction • Consider midazolam for persistent seizures. See Fitting, p. 86
Non-steroidal anti-inflammatory drugs (NSAID) Celecoxib, diclofenac, etoricoxib, ibuprofen, indomethacin, ketoprofen, ketorolac, mefenamic acid, meloxicam, naproxen, parecoxib, piroxicam, sulindac and tiaprofenic acid	<ul style="list-style-type: none"> • Symptomatic treatment and supportive care • Consider midazolam for persistent seizures. See Fitting, p. 86

Toxin specific management considerations	
Poison or toxic agent	Extra management considerations after: <ul style="list-style-type: none"> – contact with Poisons Information Centre (PIC) 13 11 26 – MO/NP consultation – Toxicology assessment
<p>Opioids</p> <p>Alfentanil, buprenorphine, codeine, dextropropoxyphene, fentanyl, hydromorphone, methadone, morphine, oxycodone, pethidine, remifentanyl, sufentanyl and tramadol</p>	<ul style="list-style-type: none"> • Potential for significant toxicity, especially in opioid naive patients and exposures to long acting preparations • Give naloxone as antidotal therapy • Check for and remove opioid transdermal patches
<p>Pesticides or insecticides (organophosphates)</p> <p>Chlorpyrifos, diazinon, dimethoate, fenthion and malathion</p>	<ul style="list-style-type: none"> • Strict PPE precautions • For dermal exposures, remove all clothing and shower with soap and water • Stat doses or infusion of IV atropine to treat bradycardia • Consider midazolam for persistent seizures. See Fitting, p. 86
<p>Paracetamol</p>	<ul style="list-style-type: none"> • Give IV acetylcysteine. Brought with retrieval team
<p>Potassium</p>	<ul style="list-style-type: none"> • Activated charcoal is not indicated • Consider calcium gluconate for cardiac arrhythmias • To decrease serum potassium give: <ul style="list-style-type: none"> – IV insulin + glucose and – sodium bicarbonate and – nebulised salbutamol
<p>Selective serotonin reuptake inhibitor (SSRI)</p> <p>Citalopram, dapoxetine, escitalopram, fluoxetine, fluvoxamine, paroxetine and sertraline</p>	<ul style="list-style-type: none"> • Symptomatic treatment and supportive care
<p>Serotonin and noradrenaline reuptake inhibitors (SNRIs)</p> <p>Atomoxetine, desvenlafaxine, duloxetine, reboxetine and venlafaxine</p>	<ul style="list-style-type: none"> • Symptomatic treatment and supportive care • Consider midazolam for persistent seizures. See Fitting, p. 86 • Consider benzodiazepines for agitation. See Mental health emergency, p. 336
<p>Stimulant drugs</p> <p>Amphetamines, cocaine, dexamphetamine, MDMA (ecstasy), methylphenidate, piperazines and lisdexamfetamine</p>	<ul style="list-style-type: none"> • Active rapid cooling for Hyperthermia, p. 188 • Consider benzodiazepines for stimulant induced hypertension or tachycardia • Consider benzodiazepines for agitation. See Mental health emergency, p. 336 • Consider midazolam for persistent seizures. See Fitting, p. 86 • Consider hypertonic saline for severe hyponatraemia

Toxin specific management considerations	
Poison or toxic agent	Extra management considerations after: <ul style="list-style-type: none"> – contact with Poisons Information Centre (PIC) 13 11 26 – MO/NP consultation – Toxicology assessment
Sulfonylurea Glibenclamide, gliclazide, glimepiride and glipizide	<ul style="list-style-type: none"> • Treat hypoglycaemia with glucose. See Hypoglycaemia, p. 91
Super warfarins (rat and mouse poison) Brodifacoum, bromadiolone, coumatetralyl, difenacoum difethialone, diphacinone, flocoumafen and pindone	<ul style="list-style-type: none"> • Consider antidotal vitamin K (phytomenadione)
Theophylline and caffeine	<ul style="list-style-type: none"> • Consider metaraminol or noradrenaline for hypotension unresponsive to IV fluids • Consider midazolam for persistent seizures. See Fitting, p. 86 • Consider benzodiazepines for agitation. See Mental health emergency, p. 336 • Consider potassium chloride to treat hypokalaemia • Give antiemetic for Nausea and vomiting, p. 40
Toxic alcohol Methanol (model aeroplane fuel, rocket fuel, racing car fuel and poorly distilled alcohol) Ethylene glycol (coolants, antifreeze, brake fluids and some solvents)	<ul style="list-style-type: none"> • Treat with fomepizole (very expensive/may not be available) or ethanol • Activated charcoal is not indicated • If ethanol 10% is not available, then white spirits (eg vodka), or sweet alcoholic formulations for children, can be administered orally or via a nasogastric tube
Tricyclic antidepressants (TCAs) Amitriptyline, clomipramine, dothiepin, doxepin, imipramine and nortriptyline	<ul style="list-style-type: none"> • Potential for significant toxicity, symptoms develop early within first few hours • IV sodium bicarbonate for QRS widening • Consider midazolam for persistent seizures. See Fitting, p. 86
Warfarin (also see Super warfarins)	<ul style="list-style-type: none"> • Consider antidotal vitamin K (phytomenadione)

Unscheduled	Activated charcoal			Prescribing guide
Only give on advice of MO/NP or PIC				
Form	Strength	Route	Dose	Duration
Oral liquid	50 g/250 mL	Oral Nasogastric Orogastric	Adult 50 g Child 1 g/kg (max. 50 g)	stat Repeat doses on MO/NP or PIC advice
Offer CMI: May cause colicky abdominal pain, nausea, vomiting or constipation				
Note: Never administer to unconscious, sleepy or dizzy patient unless intubated. Rarely indicated in children unless risk suggests poor outcome. Improve palatability by chilling, serve in a covered container with a straw, drink with eyes shut etc				
Contraindication: Children < 6 years of age with accidental liquid paracetamol ingestion. Strong acids or alkalis, iron sulfate or iron salts, cyanides, sulfonyleureas, malathion, lithium, ethanol, methanol, ethylene glycol, hydrocarbons. Bowel obstruction				
Management of associated emergency: Consult MO/NP. See Anaphylaxis, p. 82				2,3

S4	Acetylcysteine			Prescribing guide
RIPRN and RN only. Must be ordered by an MO/NP				
Form	Strength	Route	Dose	Duration
Injection	200 mg/mL	IV	Adult Loading dose 200 mg/kg (max. 22 g) *Dilute in 500 mL glucose 5% infuse over 4 hours Maintenance dose 100 mg/kg (max. 11 g) *Dilute in 1000 mL glucose 5% infuse over 16 hours	Total dose 300 mg/kg over 20 hours
			Child Loading dose 200 mg/kg *Dilute in 7 mL/kg glucose 5% (up to 500 mL) infuse over 4 hours Maintenance dose 100 mg/kg *Dilute in 14 mL/kg glucose 5% (up to 1000 mL) infuse over 16 hours	
Offer CMI: May cause flushing, urticaria and itch. Anaphylaxis is common (1%)				
Note: Calculation errors may lead to potentially fatal dosing errors. Calculate dose using actual body weight (rounded up to the nearest 10 kg) to a max. body weight of 110 kg. *Can also be diluted with sodium chloride 0.9%				
Management of associated emergency: If anaphylaxis, stop infusion. See Anaphylaxis, p. 82 Contact MO/NP				4-7

S ₃	Naloxone			Extended authority ATSIHP/IHW
ATSIHP, IHW, RIPRN and RN may proceed				
Form	Strength	Route	Dose	Duration
Injection	400 microg/ mL	IM	Adult and child 400–800 microg*	stat Can repeat after 2–3 minutes/as per MO/NP order
Nasal spray	1.8 mg/ actuation	Intranasal	Adult and child 1.8 mg (1 spray into 1 nostril)	stat Can give 2nd dose (using new device) into other nostril after 2–3 minutes
Note: *In adults, 800 microg is most appropriate to achieve adequate respiration, reverse coma and avoid the need for repeated doses. Be guided by pupil size and clinical response. Patient should improve in 1 minute. Failure to respond to 2 mg may indicate another cause of unconsciousness. The duration of naloxone is short (15–30 minutes) compared to opioids. Continue observation + monitor RR. May cause an acute withdrawal syndrome in those with opioid dependence ie anxiety, agitation, tachycardia, confusion, seizures, pulmonary oedema or arrhythmias				
Pregnancy: Can be lifesaving in acute overdose. Monitor closely in pregnancy, lactation and neonates of opioid dependent mothers				
Management of associated emergency: Consult MO/NP. See Anaphylaxis, p. 82				8-10

5. Follow up

- As advised by MO/NP or PIC

6. Referral/consultation

- Consult MO/NP and PIC for all occasions if substance known or suspected to be toxic
- Always consider referral to [Child protection, p. 551](#) for a:
 - child presentation
 - child whose carer has overdosed

Bites and stings (toxinology)

HMP Snake bite - adult/child Including sea snake

Recommend¹⁻⁴

- Snake bites are a potential medical emergency and should receive high priority assessment, even if the patient appears well
- Patients must be managed in a hospital with a monitored resuscitation area, access to 24 hour formal pathology laboratory and available antivenom, by staff able to manage the complications of anaphylaxis and envenomation
- Antivenom is not indicated without signs of systemic envenomation
- MO/NP is advised to seek early expert advice. The Poisons Information Centre (PIC) 13 11 26 (24 hours) can assist

Background¹⁻⁴

- Snake bite is relatively common in regional and remote areas. Envenomation is rare
- Many Australian snakes have potentially lethal bites

1. May present with²⁻⁴

- A history of a snake bite ± bite mark or scratch
- Bite site with pain, redness and local tissue swelling
- If symptoms, may include:
 - sudden collapse or altered LOC
 - hypotension, cardiac arrest or seizure
 - nausea, vomiting, abdominal pain, headache, sweating and diarrhoea
 - bleeding gums, coughing, spitting or vomiting blood, bleeding from bite site
 - droopy eyelids, blurred or double vision
 - difficulty swallowing, breathing or speaking or respiratory arrest
 - fatigue, weakness, gait disturbances or poor coordination
- May have no symptoms

2. Immediate management^{2,4}

- **DRSABCD**. As needed, see [BLS, p. 46](#)
- Consult MO/NP immediately
- If patient has no bandage in situ:
 - quickly note features and location of bite
 - then apply **Pressure bandage with immobilisation**
- If patient has bandage in situ:
 - apply further bandages as necessary without removing the first bandage
- Insert IVC x 2

Pressure bandage with immobilisation^{3,4,6}

- Apply a broad elastic bandage (15 cm) firmly over the bite site
- Should be unable to easily slide a finger between the bandage and skin
- Apply a further bandage from the lower portion of the affected limb, upwards to cover as much of the limb as possible (see diagram), over the top of the clothes if necessary
- If the bite is on the trunk, apply direct pressure on the bite site using multiple combines and a bandage. Do not restrict breathing or chest movement or apply firm pressure to the neck or head
- Immobilise the joints either side of the bite site using a splint and bandage to restrict movement
- **Keep patient and affected limb immobilised, calm and still. Provide reassurance**
- Indicate on bandage the location of the snakebite

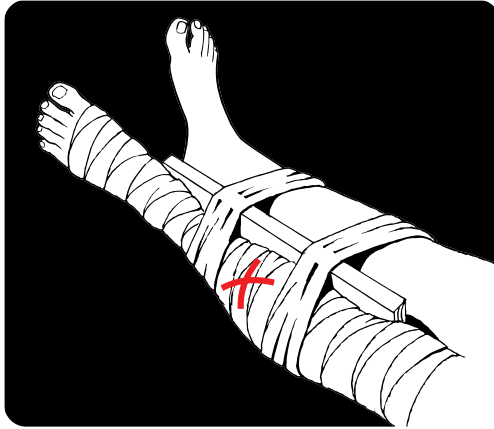

3. Clinical assessment

- Do vital signs:^{1,2,6}
 - urinalysis for blood
 - bloods - FBC, UE, CK, coagulation studies, INR, APTT, D-dimer
 - **Do not use** point-of-care/i-STAT devices for INR or D-dimer. False negative results are common
 - send pathology with evacuation team
- Get history:
 - geographic location where bite occurred ie land or water
 - location and features of bite(s) on body
 - time of bite
 - appearance of snake if seen
 - number of strikes
 - first aid measures used
 - time of bandage application
- Palpate the lymph nodes draining the bite site limb for signs of tenderness
- Check for evidence of paralysis:
 - muscles of eyes and face affected first; droopy eyelids, uncoordinated eye movements, double vision, loss of full range of eye movements
 - impaired respiratory effort or peripheral weakness

- Check for abnormal bleeding of gums, urine, bite site and IV site
- Check for muscle tenderness and weakness

4. Management^{4,7}

- **Do not remove bandage. Keep patient immobilised**
- Monitor vital signs and urine output. Insert IDC
- If hypotensive or in shock see [Shock, p. 62](#)
- Nil by mouth
- MO/NP will arrange evacuation

Antivenom administration^{1,3,5,7}

- Unless life-threatening, all cases where antivenom is considered should be discussed with tertiary facility or PIC
- Given if laboratory or clinical evidence of envenoming
- The recommended dose is 1 vial. Additional doses may be given as needed in consultation with MO/NP or PIC
- Give:
 - polyvalent snake antivenom **OR** if snake species known, then monovalent snake antivenom may be recommended by MO/NP or PIC
- Check vital signs every 5 minutes while antivenom is being administered
- Remove bandage once antivenom administered and patient is stable
- Check tetanus vaccination status and give booster if indicated. See [Tetanus immunisation, p. 557](#)

S ₄	Polyvalent snake antivenom		Extended authority ATSIHP/IHW/IPAP/RIPRN	
ATSIHP, IHW, IPAP and RN must consult MO/NP				
RIPRN must consult MO/NP unless circumstances do not allow, in which case notify MO/NP as soon as circumstances do allow				
Form	Strength	Route	Dose	Duration
Injection	40,000 units/ 50 mL Contains 5 monovalents Brown snake Tiger snake Death adder Taipan Black snake	IV	Adult and child 1 vial (40,000 units) Dilute to 500 mL sodium chloride 0.9% or Hartmann's OR if young child or at risk of fluid overload dilute to 250 mL	stat Begin infusion slowly, watching for adverse effects*. If no adverse reaction, increase rate and infuse over 15–20 minutes If signs of allergic reaction pause infusion, treat accordingly, then recommence at a slower rate Additional doses on MO/NP order
Offer CMI: May cause anaphylaxis, rash, urticaria and serum sickness				
Note: *eg erythema, urticaria, hypotension and bronchospasm. Continue to monitor for adverse effects post administration				
Contraindication: No absolute contraindications. Benefits outweigh risks				
Management of associated emergency: Ensure adrenaline (epinephrine) is drawn up and resuscitation equipment readily available. If patient develops a significant allergic reaction/anaphylaxis stop the infusion immediately and give IM adrenaline (epinephrine). See Anaphylaxis, p. 82 for doses. Consult MO/NP				

1-4

5. Follow up

- If antivenom is used, complete and send off the questionnaire that comes with each ampoule
- Patients treated with antivenom may develop serum sickness within 14 days after administration:²
 - flu-like illness with fever
 - joint and muscle pain
 - general malaise
 - treat with antihistamines or oral corticosteroids and reassure

6. Referral/consultation

- Consult MO/NP or PIC on all occasions of snake bite

HMP Funnel-web (big black) spider bite - adult/child

Recommend

- For suspected funnel-web spider bites contact the Poisons Information Centre (PIC) ☎ 13 11 26 (24 hours)

Background^{1,2}

- Severe systematic envenomation can develop within 30 minutes and almost always < 2 hours

1. May present with¹

- History of painful bite by big black spider with large fangs ± signs of envenomation:
 - severe pain and bleeding at bite site
 - minimal local reaction - no swelling or redness
 - tongue and other muscle twitching, tingling of the lips
 - watery eyes, goosebumps, sweating, excessive drooling
 - abdominal pain, nausea, vomiting, headache
 - hypertension, bradycardia or tachycardia
 - breathlessness
 - anxiety
 - in young children, inconsolable crying, drooling, vomiting or collapse¹

2. Immediate management^{1,2}

- **DRSABCD.** As needed, see [BLS, p. 46](#)
- Notify MO/NP
- **Apply pressure bandage with immobilisation.** See [Snake bite, p. 222](#) for technique
- Insert IVC

3. Clinical assessment²

- Get history:
 - description of spider (if seen)
 - time of bite
 - location and features of bite site
 - geographical location where bite occurred
 - first aid measures used

- Do:
 - vital signs
 - ECG and continue to monitor HR + rhythm
 - physical examination, noting signs of envenomation above

4. Management

- Nil by mouth
- Consult MO/NP who may arrange:
 - evacuation/hospitalisation
 - administration of antivenom
- If patient shows signs of envenomation, administer funnel web spider antivenom:^{1,4,5}
 - 2 vials initially
 - further doses on advice from MO/NP or PIC
- Remove the pressure bandage with immobilisation in a facility where antivenom is available:⁶
 - after antivenom has been administered or
 - the patient is asymptomatic
- **Monitor closely**
- Check tetanus vaccination status and give booster if indicated. See [Tetanus immunisation, p. 557](#)

S4	Funnel web spider antivenom		Extended authority ATSIHP/IHW/IPAP/RIPRN	
ATSIHP, IHW, IPAP and RN must consult MO/NP				
RIPRN must consult MO/NP unless circumstances do not allow, in which case notify the MO/NP as soon as circumstances do allow				
Form	Strength	Route	Dose	Duration
Injection	<p>125 units</p> <p>Reconstitute each vial with 10 mL water for injections (gently swirl - may take up to 10 minutes to dissolve)</p>	IV	<p>Adult and child 2 vials</p> <p>Dilute in 100 mL sodium chloride 0.9% OR if young child or at risk of fluid overload dilute dilute in 50 mL</p>	<p>stat</p> <p>Begin infusion slowly, watching for adverse effects*. If no adverse reaction, increase rate and infuse over 15–20 minutes</p> <p>If signs of allergic reaction pause infusion, treat accordingly, then recommence at a slower rate</p> <p>May be repeated in 15 minutes on MO/NP order</p>
Offer CMI: May cause anaphylaxis, rash, urticaria and serum sickness				
Note: Can be given undiluted over 2–5 minutes. *eg erythema, urticaria, hypotension and bronchospasm. Continue to monitor for adverse effects post administration				
Pregnancy: Limited data available. Benefits to mother and fetus may outweigh potential risks				
Management of associated emergency: Ensure adrenaline (epinephrine) is drawn up and resuscitation equipment readily available. If patient develops a significant allergic reaction/anaphylaxis stop the infusion immediately and give IM adrenaline (epinephrine). See Anaphylaxis, p. 82 for doses. Consult MO/NP				

1,3-5

5. Follow up

- If not evacuated/hospitalised advise to be reviewed the next day
- Patients treated with antivenom may develop serum sickness within 14 days after administration:¹
 - flu-like illness with fever
 - joint and muscle pain
 - general malaise
 - treat with antihistamines or oral corticosteroids and reassure

6. Referral/consultation

- Consult MO/NP on all occasions of suspected funnel-web spider bite

HMP Red-back spider bite - adult/child

Background¹

- Not considered life-threatening
- Management focuses on adequate analgesia

1. May present with²

- A history of being bitten by a spider ± bite marks
- Bite is not painful at first, becomes very painful 10–40 minutes later
- The pain radiates from the site and becomes regional
- Localised, patchy sweating and goosebumps within an hour around the bite site
- Red, hot or swollen bite site
- Headache, nausea, vomiting, abdominal pain
- Mild to severe hypertension and tachycardia

2. Immediate management

- **Do not** apply pressure bandage with immobilisation. Not required

3. Clinical assessment

- Get history:
 - description of spider (if seen)
 - time of bite
 - location and features of bite site
 - geographical location where bite occurred
 - first aid measures
- Do:
 - vital signs
 - physical examination, noting signs of envenomation above

4. Management^{1,3}

- Reassure the patient
- Apply ice pack to bite site
- Offer analgesia. See [Acute pain, p. 32](#)
- Clean the wound with soap and water to prevent secondary infection

- Consult MO/NP if:
 - child OR
 - not responding to simple analgesia OR
 - displaying clinical features of systemic envenomation
- If patient shows severe signs of envenomation MO/NP may order red-back spider antivenom if available
- Check tetanus vaccination status and give booster if indicated. See [Tetanus immunisation, p. 557](#)

5. Follow up

- Advise daily wound care and review as required

6. Referral/consultation

- Consult MO/NP if severe or persistent local or systemic symptoms

HMP Spider bites (other) - adult/child

1. May present with¹

- A history of being bitten by a spider ± bite marks or bleeding
- Site red, swelling, hot or painful
- Generalised spreading pain may suggest [Red-back bite, p. 227](#)
- Nausea, vomiting, headache
- Lethargy

2. Immediate management Not applicable

3. Clinical assessment

- Get history:
 - description of spider (if seen)
 - time of bite
 - location and features of bite site
 - geographical location where bite occurred
 - first aid measures
- Do vital signs
- Do physical examination

4. Management¹

- Reassure the patient
- Apply ice pack to bite site
- Offer analgesia. See [Acute pain, p. 32](#)
- Check tetanus vaccination status and give booster if indicated. See [Tetanus immunisation, p. 557](#)

5. Follow up

- Advise daily wound care and review as required
- Refer to MO/NP if non-healing wound

6. Referral/consultation

- Consult MO/NP if severe or persistent local or systemic symptoms

HMP Scorpion stings and centipede bites - adult/child

Background¹

- Australian scorpion and centipede species do not cause systemic envenomation

1. May present with¹

- History of sting/bite
- Observed scorpion or centipede
- Red, tender, swelling, numbness, itchiness and tingling at site
- Local pain > 15 minutes
- Rarely nausea, headache and malaise

2. Immediate management Not applicable

3. Clinical assessment

- Get history:
 - description of creature (if seen)
 - time of sting/bite
 - site location and features of the site
 - geographical location where sting/bite occurred
 - first aid measures
- Do vital signs
- Do physical examination including site and features of sting/bite

4. Management¹

- Reassure patient
- For pain consider:
 - applying an ice pack to sting/bite site, or
 - apply hot pack or immersing affected area in hot water (for centipede). First check water temperature with unaffected limb to avoid scald
 - offer analgesia. See [Acute pain, p. 32](#)
 - consult MO/NP if patient not responding to simple analgesia
- Clean the wound with soap and water to help prevent secondary infection
- Check tetanus vaccination status and give booster if indicated. See [Tetanus immunisation, p. 557](#)

5. Follow up

- Severe infection to sting/bite site occasionally occurs
- Advise daily wound care and review if required

6. Referral/consultation

- Consult MO/NP as above or if systemic symptoms persist

Tick bites - adult/child

Paralysis tick, typhus tick

1. May present with

- Tick
- Localised swelling, itching or irritation^{1,2}
- Allergic reaction or anaphylaxis
- Late presentations may show signs of tick paralysis

2. Immediate management²

- If signs of allergy, see [Anaphylaxis, p. 82](#)

3. Clinical assessment

- Get history:
 - allergies
 - geographical location where tick bite occurred
 - how long patient has had the tick
 - first aid measures
- Do vital signs
- Do physical examination:
 - ticks are difficult to find. Don't stop if one is found as there may be more
 - look in hair, between buttocks, groin, labia, ear canals and skin folds
 - inspect for lumps and swelling
- Identify signs of tick paralysis:^{1,2}
 - muscle weakness, difficulty walking, poor balance or coordination
 - numbness, tingling or weakness in limbs, hands, feet or face

4. Management

- If signs of tick paralysis consult MO/NP. Arrange evacuation/hospitalisation
- **Kill the tick** using a rapid freezing ether-containing product eg dimethyl ether spray (Medi Freeze Tick Off®) or permethrin cream to small ticks:^{1,2}
 - allow tick to drop off (may take many hours), then
 - clean the area with soap and water to prevent secondary infection¹
- **To prevent allergic reactions do NOT:**^{1,2}
 - touch or forcibly remove a tick with forceps or tick removal device
 - apply heat, kerosene, methylated spirits
- If patient has removed the tick but mouth-parts remain:^{3,4}
 - attempt to remove with tweezers or if unable, leave it alone and let the skin heal
- Check tetanus vaccination status and give booster if indicated. See [Tetanus immunisation, p. 557](#)
- Advise patient:
 - apply a cold compress to reduce pain and swelling^{1,2}
 - check bite site daily ± wound care
 - site may remain swollen or inflamed or worsen up to 48 hours after tick removal. Return if concerned
 - return if you experience chills, fever, headache, muscle pain or rash
 - continue to watch for symptoms for 4 weeks³

5. Follow up

- Advise to be reviewed if concerned, feeling unwell or symptoms worsen

6. Referral/consultation

- Consult MO/NP if signs of allergic reaction or paralysis

HMP **Box jellyfish stings** - adult/child

Background¹

- Life-threatening emergency
- Consider box jellyfish if sting occurred from Bundaberg (Qld) northwards, across the northern coastline and down to Geraldton (WA)

1. May present with^{1,2}

- Cardiac arrest
- Severe pain
- Wide (up to 1 cm) whip-like sting marks, with a characteristic frosted ladder pattern
- Attached jellyfish tentacles

2. Immediate management^{1,2}

- DRSABCD
- **If cardiovascular collapse** eg hypotension, cardiac arrest, unconsciousness, seizures:
 - start CPR if cardiac arrest. May need to be prolonged (> 1 hour). See [BLS, p. 46](#)
 - give box jellyfish antivenom
 - continue to monitor for adverse effects post administration^{3,4}
- Pick off all visible tentacles
- Inactivate stinging cells by dousing the sting sites with vinegar for 30 seconds
- Insert IVC/intraosseous
- Give analgesia:
 - ice packs to affected areas
 - IV opioid may be necessary. See [Acute pain, p. 32](#)
- Consult MO/NP immediately

3. Clinical assessment

- Ask about:
 - geographical location where sting occurred
 - time of sting
 - first aid measures
- Do vital signs + ECG
- Do physical examination, including site, size and features of sting

4. Management

- Manage in a resuscitation room (if possible) in case of sudden cardiorespiratory complications
- Reassure and keep patient at rest

- Give box jellyfish antivenom for systemic envenomation
- Monitor vital signs
- Continuous cardiac monitoring for arrhythmias
- MO/NP may consider contacting Poisons Information Centre (PIC) ☎ 13 11 26 or clinical toxicologist for ongoing advice
- All patients with envenomation from box jellyfish will need evacuation/hospitalisation

S4	Box jellyfish antivenom		Extended authority ATSIHP/IHW/RIPRN	
RN must consult MO/NP				
ATSIHP, IHW and RIPRN may proceed				
Form	Strength	Route	Dose	Duration
Injection	20,000 units/vial	IV	<p>Adult and child ≥ 5 years 1 vial diluted 1:10 with sodium chloride 0.9% or Hartmann's</p> <p>Child < 5 years 1 vial diluted 1:5 with sodium chloride 0.9% or Hartmann's</p>	<p>stat Begin infusion slowly, watching for adverse effects*. If no adverse reaction, increase rate and infuse over 5–10 minutes</p> <p>If signs of allergic reaction pause infusion, treat accordingly, then recommence at a slower rate</p> <p>Further doses on MO/NP order</p>
Offer CMI: May cause anaphylaxis, rash, urticaria and serum sickness				
Note: *eg erythema, urticaria, hypotension and bronchospasm. Continue to monitor for adverse effects post administration				
Management of associated emergency: Ensure adrenaline (epinephrine) is drawn up and resuscitation equipment readily available. If patient develops a significant allergic reaction/anaphylaxis stop the infusion immediately and give IM adrenaline (epinephrine). See Anaphylaxis, p. 82 for doses.				
Consult MO/NP 2,3,5				

5. Follow up

- Advise patient they may develop a rash over the sting site after 7–14 days²
- Patients treated with antivenom may develop serum sickness within 14 days after administration:²
 - flu-like illness with fever
 - joint and muscle pain
 - general malaise
 - treat with antihistamines or oral corticosteroids and reassure

6. Referral/consultation

- As above

Background¹

- Can result in life-threatening symptoms, with some patients developing cardiac failure
- Jellyfish occur near or far offshore in tropical waters of Australia

1. May present with^{1,2}

- Stings may go unnoticed, but within 20 minutes may develop Irukandji syndrome:
 - severe generalised pain
 - sense of impending doom
 - nausea and vomiting
 - difficulty breathing, shortness of breath
 - restlessness
 - sweating

2. Immediate management

- **DRSABCD**. If needed, [BLS, p. 46](#)
- Reassure and keep patient at rest^{1,2}
- Offer analgesia. See [Acute pain, p. 32](#)
- Insert IVC
- Nil by mouth
- Consult MO/NP

3. Clinical assessment²

- Ask about - time of sting + any first aid measures
- Do vital signs +
 - monitor RR:
 - for respiratory distress
 - listen to chest sounds for pulmonary oedema eg crackles or wheeze
 - monitor BP - severe hypertension may occur
 - ECG + continuous cardiac monitoring - observe for arrhythmias until evacuation
- Check - site, size and features of sting

4. Management^{2,3}

- Give O₂ to maintain SpO₂ ≥ 94%
- Continuous monitoring of BP, HR, SpO₂, RR
- Give sublingual glyceryl trinitrate (GTN) if hypertensive
- Arrange evacuation
- MO/NP may advise:
 - commence IV GTN infusion. See [Hypertensive emergency, p. 116](#)
 - further management of pulmonary oedema
- MO/NP may contact Poisons Information Centre (PIC) ☎ 13 11 26 or clinical toxicologist
- Continue to monitor pain. See [Acute pain, p. 32](#)

S ₃	Glyceryl trinitrate (GTN)			Extended authority ATSIHP/IHW
ATSIHP, IHW, RIPRN and RN may proceed				
Form	Strength	Route	Dose	Duration
Tablet	600 microg	Subling	300–600 microg	stat
Spray	400 microg/spray		400 microg	Repeat every 5 minutes up to 3 doses provided sBP ≥ 90
Offer CMI: May cause headache, flushing, palpitations, hypotension, dizziness or fainting. Advise to get up gradually from sitting or lying				
Note: Sit before giving. Do not use tablets from bottles that have been opened > 3 months. If unopened spray, prime by pressing nozzle 5 times into the air, or if > 7 days since used, press once				
Contraindication: Hypotension (sBP < 90), patient has taken phosphodiesterase-5-inhibitors eg sildenafil (eg Viagra®), vardenafil (Levitra®) ≤ 24 hours or tadalafil (eg Cialis®) ≤ 48 hours				
Management of associated emergency: Consult MO/NP. See Anaphylaxis, p. 82 2,4				

5. Follow up

- All patients to be evacuated/hospitalised

6. Referral/consultation

- As above

HMP Bluebottle and other jellyfish stings - adult/child

Recommend¹

- Do not use vinegar as may increase pain

1. May present with^{1,2}

- Immediate burning pain (lasts up to 2 hours)
- Linear or spindle (elliptical) red welts
- Systemic effects (nausea, headache or malaise) are uncommon

2. Immediate management Not applicable

3. Clinical assessment¹⁻³

- Ask about:
 - time of sting
 - first aid measures
- Do vital signs
- Check - site, size and features of sting

4. Management¹⁻³

- Gently pick off any remaining tentacles with forceps or gloved fingers
- For pain consider:
 - applying a hot pack or immersing affected area in hot water for 20 minutes. First check water temperature with unaffected limb to avoid scald
 - offer analgesia. See [Acute pain, p. 32](#)

- Monitor for allergic reactions
- Consult MO/NP if:
 - pain not controlled by oral analgesia
 - systemic effects, or doubt over cause of sting
- Transport to hospital or further medical intervention is rarely required

5. Follow up

- If patient concerned

6. Referral/consultation

- As above

HMP Blue-ringed octopus and cone shell envenomation - adult/child

Background^{1,2}

- Venom from these creatures can cause paralysis and death from respiratory failure within 30 minutes
- Blue-ringed octopus inhabit all coastal areas throughout Australia
- Many species of cone shell are found in tropical North Australia

1. May present with

Blue-ringed octopus^{1,2}

- Often painless bite ± mark
- Collapse on or near the beach shortly after a minor sting
- Numbness of mouth, lips and tongue
- Drooping upper eyelid, blurred or double vision
- Difficulty swallowing
- Flaccid paralysis - occurs within minutes of sting
- Respiratory/cardiac arrest

Cone shell²

- Local pain, swelling and numbness
- Can progress to muscle incoordination and weakness, disturbance of speech, vision and hearing loss
- Swallowing/breathing difficulties and respiratory paralysis if severe envenomation

2. Immediate management^{1,2}

- **DRSABCD.** If needed, [BLS, p. 46](#). May require prolonged mechanical ventilation
- **Apply a pressure bandage with immobilisation.** See [Snake bite, p. 222](#) for technique
- Urgently consult MO/NP + evacuation

3. Clinical assessment

- Do vital signs + neurological assessment

- Ask about:
 - time of bite (if possible)
 - first aid measures
 - time when (if) paralysis started
- Check for:
 - site, size and features of bite
 - signs of paralysis

4. Management^{1,2}

- **Do not remove pressure bandage** with immobilisation if systemic signs of envenomation. Leave in situ until evacuated
- Offer analgesia. See [Acute pain, p. 32](#)
- Reassure and keep patient at rest
- Likely to require mechanical ventilation until respiratory paralysis resolves (2–5 days)
- Discharge patient if they remain asymptomatic for at least 6 hours

5. Follow up

- If patient concerned

6. Referral/consultation

- As above

HMP **Penetrating marine injuries** - adult/child Stingray, stonefish, bullrout, catfish, scorpionfish, lionfish, rabbitfish, other spiny fish, sea urchins

Recommend

- Do not apply pressure bandage with immobilisation

Background

- Any stingray wounds to the trunk can be life-threatening¹⁻³
- Severe systemic envenomation is rare¹
- Wounds from these injuries can become infected

1. May present with¹

- Barb puncture mark or open wound usually on hands or feet ± barb or spine in situ usually on:
 - lower legs for stingrays
 - soles of feet for sea urchins
 - hands for spiny fish due to handling
- Local trauma and intense pain
- Swelling and bruising

In severe cases

- Nausea, vomiting, headache, dizziness, SOB, diarrhoea, sweating, syncope
- Cardiovascular collapse
- Infected or necrotic wound if delayed presentation

2. Immediate management

- **Do not remove embedded barbs from chest or abdomen:**
 - VERY CAREFULLY place padding around barb and apply pressure to control bleeding³
 - see [Chest injuries, p. 140](#) or [Abdominal injuries, p. 150](#)
- To relieve pain apply a hot pack or immerse affected area in hot water up to 90 minutes. First check water temperature with unaffected limb to avoid scald^{1,2}
- If hot water is ineffective offer analgesia. See [Acute pain, p. 32](#)

3. Clinical assessment

- Ask about:
 - time and circumstances of injury
 - first aid measures
- Do vital signs +
 - x-ray or USS if available to exclude retained barb/spine²
- Check - site and nature of injury

4. Management

- Consult MO/NP for:
 - any penetrating wounds to chest, abdomen or joints
 - ineffective pain relief
 - delayed presentation of injury
 - wounds with retained barbs/spines
 - large or deep wounds likely to require antibiotic prophylaxis
 - evacuation/hospitalisation
- If experienced to do so, clean and irrigate wound thoroughly:
 - infiltrate lidocaine (lignocaine) 1% prior to wound care
 - remove any spines/barbs carefully as they break easily
 - incision may be necessary
 - do not suture wound
 - antibiotics may be necessary.^{1,2} See [Water related wounds, p. 170](#)
- Check tetanus vaccination status and give booster if indicated. See [Tetanus immunisation, p. 557](#)
- Discharge home if no systemic symptoms after 2 hours of observation

S4	Lidocaine (lignocaine)			Extended authority ATSIHP/IHW/RIPRN
ATSIHP, IHW and RN must consult MO/NP				
RIPRN may proceed				
Form	Strength	Route	Dose	Duration
Injection	1% 50 mg/5 mL	Subcut	up to 3 mg/kg (max. 200 mg)	stat
Offer CMI: It will hurt as it goes in. Report any drowsiness, dizziness, blurred vision, vomiting or tremors				
Note: Use the lowest dose that results in effective anaesthesia				
Management of associated emergency: Ensure resuscitation equipment readily available. Consult MO/NP. See Anaphylaxis, p. 82				
				1,4

5. Follow up

- Advise patient to return daily to ensure all retained spines are removed
- Monitor wound for delayed healing or infection

6. Referral/consultation

- As above

HMP Sponges - adult/child

Background^{1,2}

- Venomous sponges found in all coastal waters of Australia can cause contact dermatitis
- Sponge related injuries are rare

1. May present with^{1,2}

- Mild local itching and stinging
- Redness, swelling and joint stiffness
- Fire sponges can cause peeling of the skin 2–3 weeks after contact

2. Immediate management Not applicable

3. Clinical assessment

- Ask about:
 - time and circumstances of contact
 - first aid measures
- Do vital signs
- Check - site and nature of injury

4. Management¹

- Wash the site
- Reassure patient, treatment usually not required
- Offer analgesia. See [Acute pain, p. 32](#)
- If needed, antihistamines/other for contact dermatitis^{1,2}

5. Follow up

- Review if any ongoing symptoms

6. Referral/consultation

- Usually not required

HMP Ciguatera poisoning - adult/child

Coral trout, mackerel, red emperor, groper, cod, snapper, bass, trevally, kingfish, other large predatory saltwater fish

Background^{1,2}

- Caused by the ingestion of ciguatoxins that accumulate in some tropical fish

1. May present with^{1,2}

- History of eating a saltwater fish within last 48 hours
- Vomiting, diarrhoea and abdominal cramps
- Tingling and numbness to fingers, around mouth, lips, tongue and throat
- Burning sensation or pain on contact with cold water
- Joint and muscle pain, weakness, cramps
- Headache, fatigue, fainting
- Extreme itchiness
- Difficulty breathing in severe cases

2. Immediate management

- Do vital signs
- If hypotensive, see [Shock](#), p. 62

3. Clinical assessment

- Ask about:
 - type and amount of fish ingested
 - when ingested
 - how often fish is eaten as small doses can accumulate over time
 - if other individuals who ate the fish are feeling unwell
 - gastrointestinal symptoms prior to presentation
- Do:
 - ECG
 - bloods - UE
- Check:
 - [Hydration assessment - adult](#), p. 200 or [child](#), p. 535
 - if breastfeeding mother has consumed the fish, infant should be assessed for ciguatera poisoning

4. Management²

- Consult MO/NP
- Supportive care and reassurance
- Manage dehydration and per [Gastroenteritis - adult](#), p. 200 or [Gastroenteritis - child](#), p. 535
- Offer antiemetic. See [Nausea and vomiting](#), p. 40
- Advise patient:²
 - symptoms may take weeks to months to resolve
 - stay hydrated. Dehydration is associated with symptom recurrence²

- avoid eating the following foods for 3–6 months (associated with symptom recurrence):²
 - any type of fish, nuts, alcohol, caffeine, pork, chicken

5. Follow up

- If not evacuated/hospitalised advise to be reviewed the next day
- Consult MO/NP if there are unresolved symptoms

6. Referral/consultation

- Ciguatera is a notifiable condition in Qld . Alert Public Health Unit + see <http://disease-control.health.qld.gov.au/Condition/731/ciguatera-poisoning>

HMP Stinging tree - adult/child

Background

- Common tree in Qld rainforests with stinging hairs on leaves/twigs. Hairs contain poorly characterised toxic compounds that cause severe pain¹
- There is no high quality evidence to guide management of this condition, below are common remedies which are used in areas where the tree is endemic

1. May present with

- Severe pain or intense sharp tingling sensation after contact with tree¹⁻³
- Injured area covered with small red spots joining together to form a red, swollen mass¹

2. Immediate management

- Advise patient not to scratch or rub the area - can cause hairs to break + penetrate deeper, making them difficult to remove⁴
- Give analgesia - IV morphine or fentanyl. See [Acute pain, p. 32](#)
 - **note:** initial pain can last hours³

3. Clinical assessment

- Do vital signs

4. Management

- Hospitalisation not usually needed
- MO/NP may advise:⁵
 - diluted hydrochloric acid 10% (HCl) gauze application
 - **note: HCl is a hazardous chemical - ONLY use if local policies around use, safety + dilution/ application are available.** Incorrect preparation can cause an explosion
- Use hair removal wax strip to remove finer hairs (unless a minor sting). Do not smear wax on skin, as will cause more pain:^{2,5}
 - removing finer hairs helps to prevent further release of the toxin (hairs can continue to release toxin for up to a year)
- Apply topical anaesthetic gel after wax removal⁵
- Can also try:¹
 - applying sticking plaster + pulling it off
 - remove visible hairs with tweezers

- **Note:** sometimes the skin will close over the hairs + they can't be removed
- Advise patient:^{1,2}
 - pain/tingling and sensitivity to cold weather/water can last days or months
 - affected area can remain intermittently sensitive for a long period of time

5. Follow up

- As per MO/NP

6. Referral/consultation

- As above

Assault

Domestic and family violence - adult

Recommend¹

- If outside of Qld refer to local policy + consider mandatory reporting requirements
- Domestic and family violence (DFV) has immediate and long-term impacts on children. Always consider [Child protection, p. 551](#)

Background¹

- DFV is when one person in a relationship uses their power to control the other person in any way, including physical, emotional, verbal, sexual, financial, social, cultural and spiritual abuse
- Also see *Understanding domestic and family violence* https://www.health.qld.gov.au/__data/assets/pdf_file/0025/952072/1_Understanding-DFV-Booklet.pdf

1. May present with

- Experiencing DFV ± injuries
- Patient may not act any differently or show any outward signs, but consider:¹
 - **indicators** eg depression/anxiety symptoms, emotional lability, delay in seeking treatment, inconsistent explanation of injuries, frequent presentations, bruises in various stages of healing, chronic pain^{1,2}
 - **risk factors** eg pregnancy/new birth, isolation, court orders/proceedings, financial difficulties, perpetrators mental health status and alcohol and other drugs¹

2. Immediate management

- Assess and treat any injuries
- Consider immediate safety of yourself, the patient ± children/unborn child:
 - if concerns call police on triple zero (000)

3. Clinical assessment

- Talk to the patient alone and in private. Ask questions like:^{1,2}
 - has your partner ever threatened to hurt you or your children
 - do you have any worries about your safety or someone else's at home
 - are you afraid of your partner, do you feel safe in your relationship
 - are you safe to go home

- would you like assistance with this
- It takes courage to talk about DFV. It is important to respond sensitively:¹
 - communicate belief and validate the experience eg that must have been frightening for you, it must be difficult for you to talk about
 - affirm that violence is unacceptable
 - **never ask** why don't you leave, why did he/she hit you or what could you have done to avoid this situation
- **Patient's experiencing any of the following are at high risk of being killed or almost killed.**³ Ask about:
 - strangulation/choking/suffocation - how many times
 - escalation in severity or frequency of violence
 - recent or pending separation
 - stalking, including cyber stalking
 - access or use of weapons
 - perpetrator threatens/attempts suicide
 - threats to harm/kill children and pets
 - perpetrator unemployment
 - sexual assault
- If pregnant or new birth, check medical record for DFV screening tool ie SAFE Start Psychosocial form - this may help guide Management

4. Management

- **If patient declines to answer questions or discuss further:**¹
 - offer contact details of DFV services, see **Referral/consultation**
 - advise that he/she has right to protection and safety from DFV
 - document your conversation
- **If patient chooses to talk/asks for assistance:**¹
 - help them to call a DFV service, with consent offer to speak on their behalf and then support them until the call is complete, see **Referral/consultation** for contact details
 - contact social worker if available
 - if patient requests, contact police to assist with:
 - removing perpetrator from home
 - retrieving belongings
 - applying for a Domestic Violence Order, even if they chose to stay in the relationship
- Ensure patient has somewhere safe to go, offer to arrange refuge accommodation. If chooses to go home consider safety plan, including:^{1,4}
 - in an emergency call police on triple zero (000)
 - an escape plan - identify safe places and how to get there
- Do not engage with perpetrator in ways that might ↑ risk of DFV:¹
 - do not confront in an accusatory manner or in a way that will shame or anger them
 - never share anything the patient or children have told you
 - do not collude with their attempts to minimise, excuse or justify their violent behaviour
- **If you are not confident responding to DFV:**⁴
 - contact MO/NP/mental health clinician
 - discuss with local clinic management
 - call DVConnect for advice

5. Follow up

- Offer referral to mental health clinician, DFV specialist workers, legal services

6. Referral/consultation

- DVConnect 24 hour ☎ 1800 811 811, including assistance with refuge accommodation
- DVConnect Mensline 9 am - midnight ☎ 1800 600 636
- 1800 RESPECT, 24 hour sexual assault and domestic violence support ☎ 1800 737 732
- For **non-urgent** matters Police Link ☎ 131 444. Alternatively, online and SMS contact <https://www.police.qld.gov.au/domestic-violence>
- Find local support, including in remote areas <https://www.qld.gov.au/community/getting-support-health-social-issue/support-victims-abuse/domestic-family-violence/find-local-support>

Sexual assault - adult/child

Recommend

- If outside of Qld refer to local policy and procedures

Background

- Sexual assault is a crime and includes:¹
 - any unwanted or forced sexual act which a person does not consent eg digital rape, oral sex, groping, inappropriate touching of a sexual nature
 - sexual abuse of children
- A forensic examination is where a Sexual Assault Investigation Kit (SAIK) is used to collect DNA evidence² and may include the collection of the patient's clothes. Check local protocol, patient may require evacuation if unable to be done locally
- Also see (Qld Health intranet only):
 - *Forensic and scientific services: caring for people disclosing sexual assault* <https://qheps.health.qld.gov.au/hsq/forensics/response-to-sexual-assault>
 - *Clinical risk factors and indicators of abuse and neglect in children* <https://qheps.health.qld.gov.au/csu/factsheets>

1. May present with

- Disclosing sexual assault, rape ± injuries¹⁻³
- Trauma to genital area, anus⁴
- Child/adolescent pregnancy, STI⁴
- Accompanied by police requesting forensic examination¹

2. Immediate management

- Assess and treat any injuries:²
 - clinical interventions take priority over forensic examination
- Contact MO/NP if:
 - traumatic injuries eg head, chest, abdominal injuries
 - < 14 years of age:
 - medical and forensic examinations should be performed by MO with child protection ± sexual assault examination training/skills²
 - ongoing management as per MO/NP/paediatrician

3. Clinical assessment

- It is important that the patient feels a sense of control. **Offer:**²
 - to arrange a support person who is not a potential witness
 - move to private room
 - clinician gender preference where possible
 - reassurance that consent is needed for all parts of treatment/examination and can be withdrawn anytime
- **Ask about:**²
 - details of assault:
 - even if the details sound strange or unlikely, offer a kind response and do not ask questions like - why did you go there, how drunk were you
 - investigating the assault is a police matter, do not try to work out what did/didn't happen
 - contraception. If oral contraceptive - any missed doses in last menstrual cycle
 - tetanus and hep B vaccination status
- **Offer** a physical examination, including:
 - assessment and documentation of all injuries, use diagrams if required
 - **note:** do not perform any forensic examination unless trained to do so
- Do vital signs

4. Management

- **If < 18 years of age:**
 - sexual abuse is a crime and must be reported to police **AND**
 - as per mandatory reporting responsibilities to Child Safety.² See [Child protection, p. 551](#)
 - contact MO/NP who will refer to paediatrician for ongoing management
 - if not evacuated, before sending home consider is:
 - the home environment safe
 - there a protective parent/carer
- **If > 18 years of age:**
 - collaborate with MO/NP, Sexual Health Service or Forensic Nurse Examiner/Sexual Assault Nurse Examiner at nearest district/regional facility:
 - **note:** where there is no trained clinician to do forensic examination, evacuation may be required. Check local protocol
- Encourage patient to talk to the police. The sooner the police are aware the more chance of a conviction¹
- Timing and type of forensic examination is also dependent on:¹
 - time since the assault
 - physical and emotional state of the patient
 - their account of the assault
- **If patient wants to make a complaint to the police:**²
 - call the local police or Policelink ☎ 131 444
 - police will talk with the patient ± request forensic examination (SAIK)
 - **note:** police will supply SAIK, be physically present for the collection of evidence and take completed kit
- **If patient does not want to make a complaint or wants to defer the decision, discuss:**²
 - *Just In Case* (JIC) forensic examination - swabs are collected and stored for 12 months in case patient later chooses to make a complaint. Must be collected by trained clinician
 - reassure the patient they can talk to the police, this does not mean they have to make a complaint now

- JIC SAIK can be obtained from Pathology Qld (PQ). If no PQ, police will supply SAIK² but have no further involvement
- **note:** SAIK does not contain JIC forms eg consent, pathology. These need to be printed,² see <https://qheps.health.qld.gov.au/hsq/forensics/response-to-sexual-assault> (access via Qld Health intranet only)
- refrigerate sealed kit and send to pathology²
- **If patient does not want to report:**²
 - they can contact police later, or
 - log the details of the assault anonymously through the Alternative Reporting Option, see <https://www.police.qld.gov.au/reporting>
- Offer STI screen if indicated or patient concerned.³ See [STI/BBV tests, p. 448](#)
 - **note:** if done now patient still needs screening at 2 week follow up even if antibiotic prophylaxis is given³
- Also consider:³
 - pregnancy test for pre-existing pregnancy
 - [Emergency contraception, p. 443](#)
 - [Tetanus immunisation, p. 557](#)
 - hep B vaccine and immunoglobulin (IG) (should be given within 14 days of the assault if non-immune or incomplete vaccination)⁴
 - if mental health concerns eg self-harm, see [Mental health emergency, p. 336](#)
- Contact MO/NP who may advise:³
 - ceftriaxone, azithromycin for STI prophylaxis
 - HIV [Post-Exposure Prophylaxis, p. 477](#)
- Offer analgesia. See [Acute pain, p. 32](#)

5. Follow up

- Advise patient as indicated:
 - STI screening is recommended 2 weeks after the assault³
 - pregnancy test if next period late or different from normal³
 - hep B vaccine at 1 and 6 months after first dose⁵
 - see MO/NP at next clinic as appropriate

6. Referral/consultation

- Consult MO/NP for all sexual assaults
- Offer referral to sexual assault support service or social work³
- Other resources include:³
 - Clinical Forensic Medicine Unit ☎ 3722 1300 (after hours calls redirected to Police Comms, ask for on call forensic physician)
 - Qld Sexual Assault Helpline ☎ 1800 010 120 (7:30 am–11:30 pm, 7 days)
 - 1800 Respect, 24 hour sexual assault and domestic violence support ☎ 1800 737 732
 - Child Safety Regional Intake Service or Child Safety After Hours Service Centre ☎ 1300 681 513 or 1800 811 810
 - True Relationships & Reproductive Health www.true.org.au ☎ 3250 0240
 - Victims Assist Qld <https://www.qld.gov.au/law/crime-and-police/victim-assist-queensland>

Page intentionally left blank

General

Mild and moderate allergic reactions

HMP Urticaria, allergic rhinitis - adult/child Hives, hay fever

1. May present with

Hives (urticaria)

- Itchy rash - blotches or raised red lumps:¹
 - vary in size from pinhead to dinner plate. When first appear, can look like mosquito bites
 - usually disappear within minutes to hours in one spot, but may come and go
- ± angio-oedema - deeper swellings mostly affects face and lips:^{1,2}
 - often bigger, last longer and may itch less ± hurt or burn
- ± symptoms of viral infection - most common cause of hives in children^{1,2}
- **Note:** if hives occur within 1–2 hours of exposure (eg food, medicines, stings) and disappear within 6–8 hours, is likely an allergic reaction. Localised hives may be a contact allergy¹

Hay fever (allergic rhinitis)

- Clear rhinorrhoea, sneezing, nasal blockage, nasal itch^{3,4}
- Darkened circles around eyes ± watery, red eyes³
- Itchy throat, frequent need to clear throat³
- **Note:** symptoms can be confused with recent URTI

2. Immediate management

- If hives, check for ANY signs of anaphylaxis. If any treat urgently as per [Anaphylaxis, p. 82](#)

Signs of Anaphylaxis - any ONE of the following:⁵

- Difficult/noisy breathing
- Wheeze or persistent cough
- Swelling of tongue
- Persistent dizziness or collapse
- Swelling/tightness in throat
- Pale and floppy (young children)
- Difficulty talking ± hoarse voice
- Abdominal pain, vomiting

- Suspect [Foreign body in nose, p. 194](#) in child with any nasal occlusion, facial swelling ± pain, or smelly, purulent or blood-stained nasal discharge^{3,6}

3. Clinical assessment

- Get history, including:
 - onset/duration of symptoms
 - known allergies/triggers eg food, exercise, pollen, dust mites, mould
 - previous episodes, treatment, was it effective³
 - eczema, asthma⁶
 - **if hives:**
 - foods and medications consumed several hours before the reaction⁶
 - possible stings or bites⁶
 - symptoms of a viral infection eg fever, malaise

- **if hay fever:**
 - are symptoms there year round, seasonal or come and go
 - is it troublesome for patient/impacting on sleep, sport, work etc
- Do physical examination, including:
 - vital signs
 - if hives - check skin, describe lesions, localised/widespread

4. Management

- If angio-oedema (see above), consult MO/NP
- Advise patient to avoid/minimise exposure allergens (if known)⁴
- Give antihistamine eg cetirizine (effective for hives and hay fever)
- **If hives** advise:¹
 - keep cool, wear loose clothing
 - avoid aggravating factors eg alcohol, excessive heat, spicy foods⁷
 - do not take aspirin or other NSAIDs - can make symptoms worse
 - most hives will resolve within a couple of weeks without treatment
- **If hay fever:**⁷
 - if watery, red eyes, also see [Allergic conjunctivitis, p. 292](#) for eye drops
 - advise to see MO/NP at next clinic if:
 - severe/troublesome for patient, or has pre-existing asthma³
 - **note:** hay fever can co-exist with asthma
 - if allergic to pollens, advise may be at risk of thunderstorm asthma. Stay indoors in thunderstorms. Also see <https://www.allergy.org.au/patients/asthma-and-allergy/thunderstorm-asthma>

S2	Cetirizine			Extended authority ATSIHP/IHW/IPAP
ATSIHP, IHW and IPAP may proceed for adult and child > 12 only				
RIPRN may proceed				
RN may administer; for supply see RN supplying, p. 11				
Form	Strength	Route	Dose	Duration
Tablet	10 mg	Oral	Adult and > 12 years	10 mg mane ± repeat dose late afternoon
			6–12 years	10 mg daily OR 5 mg bd
2–6 years	5 mg daily OR 2.5 mg bd			
1–2 years	2.5 mg bd			
Oral liquid	5 mg/5 mL			While symptoms persist
Offer CMI: May cause drowsiness, fatigue, headache, nausea, dry mouth or diarrhoea. Avoid alcohol				
Note: If renal impairment seek MO/NP advice. Increased risk of sedation in elderly - monitor carefully				
Management of associated emergency: Consult MO/NP. See Anaphylaxis, p. 82				2,4,8

5. Follow up

- If symptoms continue advise to see MO/NP at next clinic, or sooner if worsen/concerned

6. Referral/consultation

- As above

Respiratory problems

HMP Upper respiratory tract infection (URTI) - adult Common cold, influenza, bronchitis

1. May present with¹

Common cold (acute viral rhinosinusitis)

- Blocked nose
- Runny nose or posterior nasal drip (can trigger cough)
- Facial pain/pressure
- ↓ sense of smell
- If fever, usually mild

Influenza

- As per common cold:
 - + sudden onset of fever, headache, muscle + joint pain, severe malaise, sore throat^{2,3}

Bronchitis - inflammation of bronchi that usually follows an URTI^{4,5}

- Cough ±
 - purulent or coloured sputum
 - SOB, wheeze
 - chest discomfort/pain due to frequent coughing
 - nasal congestion
 - headache, fever
- If cough not prominent feature, consider likelihood of other URTI eg common cold, tonsillitis, pharyngitis. See [Sore throat, p. 495](#)

2. Immediate management

- Use appropriate PPE

3. Clinical assessment

- Get history, including:¹
 - onset, duration, severity of symptoms
 - fever
 - SOB, cough, any sputum - colour
 - facial pain, chest discomfort/pain
 - asthma, COPD, immunocompromised^{1,6}
 - recent international travel⁷
- Do physical examination, including:
 - vital signs
 - check/listen for:
 - WOB
 - ↓ air entry, wheeze, crackles
 - ENT - red throat, enlarged tonsils, bulging red eardrums
 - enlarged head/neck lymph glands

4. Management

- Most respiratory tract infections are viral + get better without antibiotics⁸
- If severe symptoms + patient unwell consult MO/NP
- Paracetamol or ibuprofen if needed. See [Acute pain, p. 32](#)
- Advise to treat symptoms eg:
 - gargle warm salty water
 - suck on an ice cube or lozenges
 - have a soothing drink eg honey and lemon
 - use saline nasal drops/spray
 - wash hands, cover mouth when sneezing/coughing to help stop others catching it

Common cold likely

- Symptoms usually clear within 7 days¹
- Advise to return if develops features of bronchitis and/or [Bacterial sinusitis, p. 252](#)

Influenza likely

- Consider nose and throat swab PCR to confirm (or as per Public Health Unit advice)
- Consult MO/NP if at risk of complications (antiviral medicine(s) may be indicated), including:²
 - ≥ 65 years
 - immunocompromised, chronic conditions
 - Aboriginal and Torres Strait Islander person
 - pregnant woman
 - obesity
 - homeless person

Bronchitis likely⁴

- Advise usually resolves without antibiotics within 2–3 weeks. Cough can persist longer, sometimes up to 8 weeks
- Consider other causes of cough eg:
 - [Pneumonia - adult, p. 253](#)
 - [Asthma, p. 95](#)
 - [Pertussis, p. 508](#)
 - influenza
 - heart failure

5. Follow up

- Advise to be reviewed if not improving in a few days, symptoms worsen, new symptoms, or concerned. Consult MO/NP
- If cough continues > 3 weeks, advise to see MO/NP at next clinic - may need further investigations

6. Referral/consultation

- Laboratory confirmed influenza is notifiable ①

HMP Acute bacterial sinusitis - adult/child

1. May present with^{1,3}

- [Common cold, p. 250](#) (viral rhinosinusitis) symptoms
- + severe symptoms - present from onset of illness + persisting for 3–4 days ie:
 - T ≥ 39, purulent nasal discharge or facial pain

2. Immediate management¹

- Suspect [Foreign body in nose, p. 194](#) in child with:⁴
 - any nasal occlusion, facial swelling ± pain, or smelly, purulent or blood-stained nasal discharge
- Do vital signs
- Screen for [Sepsis, p. 64](#)
- Contact MO/NP urgently if any signs of spreading infection:^{1,3}
 - acute onset confusion
 - double or ↓ vision
 - neck stiffness, severe headache, photophobia
 - swelling or cellulitis around eyes
 - bulging eyes, painful eye movements

3. Clinical assessment

- Get history, including:
 - onset, duration, severity of symptoms
 - facial pain/tenderness
 - fever, cough, nasal discharge - colour
 - immunocompromised¹
- Do physical examination, including:
 - any facial swelling + tenderness with gentle palpation²
 - ENT

4. Management¹

- If symptoms < 3–4 days, likely viral rhinosinusitis (common cold)
- Paracetamol or ibuprofen if needed. See [Acute pain, p. 32](#)
- Consider symptomatic treatment as per [URTI - adult, p. 250](#) or [URTI - child, p. 494](#)
- Consult MO/NP if:
 - severe symptoms persisting > 3–4 days, or worsening after initial improvement, or
 - persist for > 7–10 days without improvement

5. Follow up

- Advise to be reviewed if symptoms worsen, do not improve or signs of spreading infection:¹
 - consult MO/NP

6. Referral/consultation

- As above

HMP Pneumonia - adult

1. May present with^{1,3}

- Pleuritic chest pain
- Fever, rigors
- Cough + sputum, difficulty breathing, SOB^{1,2}
- Fatigue, muscle aches/pain²
- **Always consider melioidosis** during November to May (tropic wet season) in areas north of Mackay, Tennant Creek, Port Hedland - characterised by fever, pneumonia + abscesses

2. Immediate management¹

- Do vital signs + give O₂ to maintain SpO₂ > 94% (88–92% if COPD)
- Screen for **Sepsis**, p. 64 - pneumonia is a common cause of sepsis:
 - continue to manage as per **Sepsis** if indicated
- Insert IVC as needed

3. Clinical assessment

- Get history, ask about:
 - pleuritic chest pain, fever, rigors, night sweats¹
 - cough, sputum - purulent or coloured
 - ↑ RR at rest, SOB
 - immunocompromised, diabetes, chronic kidney disease, chronic lung disease¹
 - hazardous alcohol intake¹
 - recent travel^{1,2}
 - any exposure to muddy soil/water
- Do physical examination, including:
 - check/listen for:
 - WOB
 - ↓ air entry, wheeze
 - crackles - do they clear on coughing¹
 - dullness on percussion
 - check skin for ulcers, abscesses, non-healing sores

4. Management¹

- Contact MO/NP in all cases, who may advise:
 - chest x-ray
 - antibiotics ±
 - blood cultures ± urea, lactate, FBC, UE, LFT, glucose, blood gas
 - sputum (if able) for MCS ± PCR
 - IV fluids
 - evacuation
- Evacuation/hospitalisation needed if:¹
 - RR ≥ 22, HR ≥ 100, SBP < 90
 - SpO₂ < 92% on room air (or lower than normal if COPD)
 - acute onset confusion
 - chest x-ray shows multilobar involvement
 - other factors eg comorbidities, social circumstances, age ≥ 65

- If assessed as not needing evacuation, MO/NP may advise:
 - oral amoxicillin OR daily IM procaine penicillin (if allergy to penicillin give oral doxycycline)
- Advise symptoms should steadily improve once treatment is started:¹
 - fever should ↓ within the first few days and appetite will improve
 - other symptoms may take weeks to resolve
- **If melioidosis suspected** - MO/NP may order additional/alternative IV antibiotics

S4	Amoxicillin			Extended authority ATSIHP/IHW/IPAP
ATSIHP, IHW, IPAP, RIPRN and RN must consult MO/NP				
Form	Strength	Route	Dose	Duration
Capsule	500 mg	Oral	1 g tds	5–7 days
Offer CMI: May cause rash, diarrhoea, nausea or thrush				
Contraindication: Severe or immediate allergic reaction to a penicillin. Be aware of cross-reactivity between penicillins, cephalosporins and carbapenems				
Management of associated emergency: Consult MO/NP. See Anaphylaxis, p. 82				1,4

S4	Procaine benzylpenicillin (procaine penicillin)			Extended authority ATSIHP/IHW/IPAP
ATSIHP, IHW, IPAP, RIPRN and RN must consult MO/NP				
Form	Strength	Route	Dose	Duration
Prefilled syringe	1.5 g/3.4 mL	IM	1.5 g daily	5–7 days
Offer CMI: May cause diarrhoea, nausea and pain at injection site				
Contraindication: Severe or immediate allergic reaction to a penicillin. Be aware of cross-reactivity between penicillins, cephalosporins and carbapenems				
Management of associated emergency: Consult MO/NP. See Anaphylaxis, p. 82				1,5

S4	Doxycycline			Extended authority ATSIHP/IHW/IPAP
ATSIHP, IHW, IPAP, RIPRN and RN must consult MO/NP				
Form	Strength	Route	Dose	Duration
Tablet	50 mg, 100 mg	Oral	100 mg bd	5–7 days
Offer CMI: Take with food or milk to reduce stomach upset. May cause nausea, vomiting, diarrhoea, epigastric burning, tooth discolouration or photosensitivity. Take with a large glass of water. Do not lie down for an hour after taking. Do not take iron, calcium, zinc or antacids within 2 hours. Avoid sun exposure				
Pregnancy: Safe in the first 18 weeks				
Contraindication: Serious allergy to tetracyclines. Taking oral retinoids. After 18 weeks of pregnancy				
Management of associated emergency: Consult MO/NP. See Anaphylaxis, p. 82				6

5. Follow up

- Advise for review daily until improved, or earlier if symptoms worsen or concerned:
 - if no improvement or worsening consult MO/NP
- Advise to see at next MO/NP clinic

6. Referral/consultation

- Laboratory confirmed melioidosis is notifiable ⓘ

Tuberculosis - adult/child

Recommend

- Always seek advice for assessment + management from local Tuberculosis (TB) Control Unit:
 - Qld contact numbers <https://www.health.qld.gov.au/clinical-practice/guidelines-procedures/diseases-infection/diseases/tuberculosis/contact-a-service>
 - if outside of Qld contact local Public Health Unit

Background¹

- Air borne lung disease is the most common form of TB. Approx. 1500 cases are notified in Australia each year²
- Cure rates of TB with standardised treatments in drug sensitive disease is 98%
- Drug resistant TB has emerged globally and is an ongoing concern in Australia
- Countries with the most severe burden include PNG, China, DR Congo, Ethiopia, India, Indonesia, Kenya, Mozambique, Myanmar, Nigeria, South Africa, Thailand, Zimbabwe.³ Also see World Health Organisation (WHO) TB country profiles <http://www.who.int/tb/country/data/profiles/en/>
- Groups more susceptible to infection + progression to active TB:¹
 - children < 5, adolescents, elderly, malnourished, immunocompromised (eg diabetes, renal failure), taking medicines that can cause immunosuppression (eg corticosteroids, anti-cancer treatments)

1. May present with^{1,2}

- Common symptoms of pulmonary TB include:¹
 - cough > 3 weeks, sometimes with haemoptysis
 - fever + night sweats
 - weight loss
 - feeling generally tired + unwell
- Have a high clinical suspicion of TB in any person with:¹
 - risk of exposure, and:
 - respiratory infection unresponsive to standard treatments, or
 - unexplained non-respiratory illness
 - in particular if:
 - travel/arrival from high incidence countries
 - contact of an active case within past 5 years
 - history of previous TB treatment
 - Aboriginal and Torres Strait Islander person in localised area eg NT, North Qld
 - HIV positive
 - overcrowded living conditions
- Non-pulmonary TB (disease involving organs other than lungs) may present with:¹
 - a wide range of symptoms, depending on site of disease
 - often accompanied by intermittent fever or weight loss

2. Immediate management Not applicable

3. Clinical assessment

- If TB is suspected:^{1,4}
 - use PPE including high filtration mask ie P2/N95 mask
 - if the facility has a negative pressure room, immediately place patient into room
 - if no negative pressure room separate patient from others:

- outside; or in well ventilated area, windows open, ceiling fans on
- do not place in a room with re-circulating air conditioning system
- Get history of symptoms, including onset date of any:⁵
 - cough - productive/haemoptysis
 - fever, night sweats
 - weight loss
 - swollen and/or painful lymph nodes
 - any other signs/symptoms
- Get past history. Ask about:¹
 - past episodes or exposure to TB - when, treatment
 - close contact with someone with TB - when/who
 - travel to TB known area eg PNG
 - chronic disease eg diabetes, liver or renal disease
 - cancer, seizures, leukaemia, lymphoma, HIV
 - major abdominal surgery
 - organ transplant
 - currently pregnant - gestation
 - medications - any immunosuppressive therapy
- Get social history:⁵
 - occupation/number in household
 - bong smoking, illicit drug use, betel nut use
 - incarceration (prison time)
 - alcohol/smoking history
- Do physical examination, including:⁵
 - vital signs
 - weight + height
 - respiratory assessment
 - palpation of lymph nodes - note if any > 1 cm, and have been there > 1 month

4. Management^{1,4}

- For any patient with suspected TB:
 - consult MO/NP
 - contact local TB Control Unit or Public Health Unit for advice + management
- Give patient a fluid repellent surgical mask to wear + educate on coughing etiquette
- Get sputum samples x 3 on separate days:^{1,4}
 - 1 'spot sputum' at presentation
 - 2 early morning samples - can give sterile container to patient to take home
 - request AFB/GXP on pathology form
 - ideally sample should be obtained in negative pressure room if available
 - otherwise, ask patient to go to a well-ventilated area, away from other patients eg outside
 - if patient has difficulty expectorating, seek advice from TB Control Unit
- **Note:** the gold standard test for TB is AFB, but the culture takes a long time + can delay treatment. A Quantiferon Gold blood test may be helpful in the first instance whilst awaiting culture results⁶
- Take blood for HIV
- Do chest x-ray - regardless of symptoms
- MO/NP may advise:⁴
 - evacuation if critical or suspected multidrug resistant TB, or

- isolate in community to wait for sputum results, or
- evacuation for non-critical cases, but where isolation in the community is not possible
- If evacuated, patient should:⁴
 - wear a surgical mask. Does not need P2/N95
 - not travel on commercial airlines or travel with other patients UNLESS the MO/NP determines they are clinically non-infectious
- Diagnosis must be conveyed to:⁴
 - transferring crew
 - receiving hospital - so single room can be prepared

5. Follow up

- As determined by TB Control Unit or MO/NP

6. Referral/consultation

- Always contact TB Control Unit for advice
- TB is a notifiable disease ①

Mouth and dental problems

HMP Trauma to teeth - adult/child

Knocked out tooth, displaced tooth, broken tooth

Recommend

- Offer education on how to manage a knocked out 'adult' tooth. Prompt first aid may end up saving a tooth

1. May present with

- Knocked out, displaced, broken tooth/teeth
- Bleeding in mouth
- Injury/swelling to lips, tongue/face

2. Immediate management¹

- If a knocked out **adult** tooth:
 - replant within 15 minutes if possible - see how to do this under **Management**

3. Clinical assessment¹

- If practical, find all missing teeth/tooth fragments
- Ask about:
 - circumstances of injury
 - current medications
- Do vital signs
- Inspect mouth, teeth, soft tissues/gums
- Assess for bleeding +
 - bite - suspect jaw or facial fracture if bite is abnormal. See [Fractured jaw, p. 157](#)

- Check for other injuries, especially head and neck¹
- If a tooth looks like it is missing, but not found at site of the accident, assess if:
 - patient has inhaled the tooth, OR
 - tooth has been forced up into the socket completely, appearing to be missing (covered in a clot)
 - if not sure, consult MO/NP/dentist who may consider x-ray¹

4. Management

- Control any bleeding with gentle pressure:
 - if bleeding continues, see [Post tooth extraction bleeding, p. 270](#)
- Offer analgesia - ibuprofen preferred.² See [Acute pain, p. 32](#)
 - add paracetamol if needed
 - advise to take regularly, rather than as required, for continuous pain relief

Knocked out tooth¹

- Check if it is an adult or baby tooth:
 - baby teeth - smaller, lighter in colour
 - a child > 5 years may have a mixture of adult and baby teeth, can be hard to tell
- **Do NOT replant a knocked out baby tooth** - can damage the developing adult tooth
- **Replant permanent (adult) tooth within 15 minutes if possible** - more likely to heal:
 - if done > 1 hour, unlikely to succeed
- Check tetanus vaccination status and give booster if indicated. See [Tetanus immunisation, p. 557](#)

How to replant a knocked out adult tooth¹

- Hold tooth carefully by the top (crown), not the root
- Check the tooth is intact - sometimes the root may have broken off:
 - if suspect it is not intact, consider urgent dental review ± x-ray before replanting
- If dirty, rinse tooth briefly with dairy milk or sodium chloride 0.9%:
 - **do NOT use water.** Do not rub or scrub
- Replace tooth in the socket with firm finger pressure:
 - be careful to **ensure the tooth is placed the right way around.** Take extra care if multiple teeth lost
- Use **Temporary splint** to hold in place (see below)
- Advise:
 - soft diet
 - use chlorhexidine gluconate 0.2% mouthwash. See [Gum disease, p. 272](#) for instructions
- **ALL re-implanted teeth need urgent review and treatment by dentist:**
 - arrange evacuation as needed

Temporary splint¹

- Fix the replanted tooth to the adjacent teeth:
 - use a small piece of folded aluminium foil or malleable material eg Blu Tack®, orthodontic wax
 - put firmly over replanted tooth and teeth either side, so adjacent teeth act as a splint. Ask the patient to bite down to hold in position
 - if a delay in dental treatment is expected, dentist may recommend tissue adhesive or other adhesive material to bond the tooth to adjacent teeth

- **Start antibiotics after replanting the tooth:**¹
 - doxycycline if not allergic and ≥ 8 years of age **OR**
 - amoxicillin if not allergic for child < 8 years, or if doxycycline allergy in adult:
 - if allergic to amoxicillin, consult MO/NP/dentist

If unable to replant a knocked out tooth¹

- Do not let the tooth dry out
- Store in dairy milk - cool or room temperature. Tooth ligament cells can **survive in milk up to 6 hours**
- If milk not available, store in sodium chloride 0.9% or saliva + plastic wrap - get patient to spit saliva into wrap first. Ligament cells can **survive up to 1 hour** if stored this way
- **Do NOT store in water**
- **Consult dentist urgently**

Displaced tooth¹ - tooth is still in the socket, but moved position

- Do not reposition a baby tooth
- Reposition adult tooth to original position with firm finger pressure
- Put [Temporary splint, p. 258](#) on tooth
- **Consult dentist urgently** - arrange evacuation as needed

Broken tooth/teeth³

- Keep tooth fragments, as dentist may be able to be re-bond onto the broken tooth
- If no pain from broken tooth, treatment is not urgent - refer to the next dental clinic
- If pain, dentine or pulp may have been exposed
- **Exposure of dentine:**
 - intermittent pain when exposed to stimulus - hot, cold or sweet food or drinks
 - cover any obvious cavity with orthodontic wax or other inert material eg Blu Tack® or temporary filling eg Cavit®²- **note:** will not last very long
 - analgesia not normally needed
 - advise to **see dentist as soon as possible**
 - avoid stimulus eg hot/cold drinks
- **Exposure of pulp:**
 - red soft tissue is seen in the area of break or cavity
 - severe pain persisting as a dull throbbing ache - even after removal of the stimulus
 - very sensitive to touch, may bleed or have a blood clot over it
 - **needs urgent dental treatment:**
 - within 24 hours to avoid infection/more damage
 - arrange evacuation as needed
 - **if delay to treatment expected,** consult dentist who may advise:
 - orthodontic wax or other inert material eg Blu Tack®, to cover the broken tooth to ↓↓ pain
 - OR temporary filling eg Cavit®
 - **note:** these measures may still not be successful in ↓↓ pain adequately. Consult dentist

S4	Doxycycline			Extended authority
ATSIHP, IHW and IPAP must consult MO/NP				
RN must consult MO/NP/dentist				
RIPRN may proceed				
Form	Strength	Route	Dose	Duration
Tablet	50 mg 100 mg	Oral	Adult 100 mg daily Child ≥ 8 daily < 26 kg: 50 mg 26–35 kg: 75 mg > 35 kg: 100 mg	7 days
Offer CMI: Take with food or milk to reduce stomach upset. May cause nausea, vomiting, diarrhoea, epigastric burning, tooth discolouration or photosensitivity. Take with a large glass of water. Do not lie down for an hour after taking. Do not take iron, calcium, zinc or antacids within 2 hours. Avoid sun exposure				
Pregnancy: Safe in the first 18 weeks				
Contraindication: Serious allergy to tetracyclines. Taking oral retinoids. After 18 weeks of pregnancy				
Management of associated emergency: Consult MO/NP. See Anaphylaxis, p. 82 ^{1,4}				

S4	Amoxicillin			Extended authority
ATSIHP, IHW and IPAP must consult MO/NP				
RN must consult MO/NP/dentist				
RIPRN may proceed				
Form	Strength	Route	Dose	Duration
Capsule	250 mg 500 mg	Oral	Adult 500 mg tds Child 15 mg/kg (max. 500 mg) tds	7 days
Oral liquid	250 mg/5 mL 500 mg/5 mL			
Offer CMI: May cause rash, diarrhoea, nausea or thrush				
Contraindication: Severe or immediate allergic reaction to a penicillin. Be aware of cross-reactivity between penicillins, cephalosporins and carbapenems				
Management of associated emergency: Consult MO/NP. See Anaphylaxis, p. 82 ^{1,5}				

5. Follow up

- As per dentist's advice. Refer for next dentist clinic visit

6. Referral/consultation

- Consult MO/NP/dentist as above. Consider telehealth consult with dentist

Background¹

- There is insufficient evidence to support the use of Oil of Cloves for toothache. Ingestion can cause life-threatening adverse reactions in children, + safety has not been established in pregnant + lactating women

1. May present with²

- Toothache/dental pain
- Tooth/teeth sensitive to hot/cold
- With or without:
 - bad breath (halitosis) ± bad taste in mouth
 - tooth decay - hole in tooth, broken down tooth, darkened tooth
 - facial swelling ± dental abscess (gum boil)

2. Immediate management Not applicable

3. Clinical assessment²

- Get history - use [Common causes of dental pain, p. 262](#) table for prompts:
 - pain
 - associated symptoms eg bad breath, facial swelling, fever
 - dental history as appropriate
- Do vital signs
- Inspect oral cavity, teeth, soft tissues, lymph nodes, ears

4. Management²

- Use [Common causes of dental pain, p. 262](#) table to guide treatment
- **Refer anyone with toothache to a dentist** - dental treatment is the most effective means of reducing pain²
- Offer analgesia.² See [Acute pain, p. 32](#)
 - ibuprofen preferred
 - add paracetamol if needed
 - advise to take regularly, rather than as required, to achieve continuous pain relief
 - if not effective, consider oxycodone (adult)
- Give analgesia for shortest duration possible, no more than 5 days without review²
- If severe pain consult MO/NP/dentist
- Reinforce good oral hygiene. See the *Chronic conditions manual* <https://www.health.qld.gov.au/rrcsu/clinical-manuals/chronic-conditions-manual-ccm>

Common causes of dental pain ²		
Pain/symptoms	Likely cause	Management
<ul style="list-style-type: none"> • Intermittent pain: <ul style="list-style-type: none"> – felt when tooth exposed to a stimulus eg hot, cold or sweet food/drink(s) – resolves once stimulus removed 	<p>Reversible pulpitis</p> <p>(inflammation of the dental pulp tissue)</p>	<ul style="list-style-type: none"> • Avoid food or drink that provoke pain • Cover any obvious cavity with an inert material eg Blu Tack® or orthodontic wax • Advise to see dentist as soon as possible • Analgesia and antibiotics not needed
<ul style="list-style-type: none"> • Severe pain: <ul style="list-style-type: none"> – can wake person up at night – felt when tooth exposed to a stimulus eg hot, cold or sweet food/drink(s) – persists as a dull throbbing ache after stimulus removed – can be continuous 	<p>Irreversible pulpitis</p> <p>(inflammation of the dental pulp tissue)</p>	<ul style="list-style-type: none"> • Avoid food or drink that provoke pain • Cover any obvious cavity with an inert material eg Blu Tack® or orthodontic wax • Advise to see dentist as soon as possible: <ul style="list-style-type: none"> – root canal treatment or extraction may be needed
<ul style="list-style-type: none"> • Dull throbbing ache: <ul style="list-style-type: none"> – NOT triggered by a stimulus eg hot, cold or sweet food/drink(s) • Tooth may be sore to bite on 	<p>Infected root canal</p>	<ul style="list-style-type: none"> • Urgent dental review • If dental treatment unlikely in 24 hours, may need antibiotics: <ul style="list-style-type: none"> – see Tooth abscess, p. 267
<ul style="list-style-type: none"> • Tenderness of the tooth on biting 	<p>Cracked tooth or Infection near tooth</p>	<ul style="list-style-type: none"> • Can be difficult to differentiate so refer to dentist urgently • If local infection confirmed and dental treatment not likely in 24 hours, may need antibiotics: <ul style="list-style-type: none"> – see Tooth abscess, p. 267
<ul style="list-style-type: none"> • Facial swelling and pain following a toothache 	<p>Tooth abscess</p>	<ul style="list-style-type: none"> • See Tooth abscess, p. 267
<ul style="list-style-type: none"> • Pain worsens when head is tilted forwards 	<p>Maxillary sinusitis</p>	<ul style="list-style-type: none"> • Treat symptoms • Antibiotics rarely needed
<ul style="list-style-type: none"> • Acute onset of severe pain throughout the mouth + <ul style="list-style-type: none"> – gum bleeding, necrosis or ulcers of the gum – ± bad breath • Smokers are at high risk 	<p>Necrotising gingivitis</p>	<ul style="list-style-type: none"> • See Gum disease, p. 272
<ul style="list-style-type: none"> • Acute pain near front of ear on 1 or both sides • Mouth opening may be restricted • Patient may feel bite is not quite right 	<p>Temporomandibular disorder</p>	<ul style="list-style-type: none"> • Rest the jaw, avoid extreme jaw movements eg yawning • Cold or warm compresses • Refer to dentist

5. Follow up

- Refer to next dentist clinic

6. Referral/consultation

- Consult MO/NP/dentist as above. Consider telehealth consult with dentist

HMP Dental caries - adult/child Tooth decay

Background

- Aboriginal and Torres Strait Islander people + people from rural and remote areas are at high risk of dental caries¹
- Application of fluoride varnish 2–4 times a year to primary (baby) + permanent (adult) teeth is associated with a substantial reduction in the extent of caries experienced²

1. May present with

- Tooth/teeth sensitive to hot/cold, biting or pressure
- Dental caries (tooth decay) - hole in tooth, broken down tooth, darkened tooth
- Risk factors for ↑ risk of dental caries¹ - see the *Chronic conditions manual* <https://www.health.qld.gov.au/rccsu/clinical-manuals/chronic-conditions-manual-ccm>

2. Immediate management Not applicable

3. Clinical assessment³

- Ask when last dental visit was
- Assess for risk factors for dental caries
- Examine teeth for dental caries:
 - holes/cavities or structural damage which can be brown or black in appearance
 - tooth/teeth surfaces with a white or frosty appearance may indicate early stages of decay
 - pain or sensitivity
 - bad breath or a bad taste in the mouth

4. Management³

- If toothache, see [Toothache, p. 261](#)
- Ask about any adverse experience associated with previous fluoride varnish application
- Offer to apply fluoride varnish to teeth if:
 - there is evidence of dental caries or person is at high risk of dental caries +
 - regular brushing with fluoride toothpaste is likely to be ineffective +
 - person is > 18 months old +
 - there are no contraindications
- Refer for dentist review
- If patient has been recalled for re-application of fluoride varnish:
 - assess for any changes in risk status
 - check if patient has had fluoride varnish applied anywhere else during the recall period eg by a dentist
 - reapply as indicated

- Reinforce good oral hygiene. See the *Chronic conditions manual* <https://www.health.qld.gov.au/rcsu/clinical-manuals/chronic-conditions-manual-ccm>

Application of fluoride varnish⁴

- Obtain valid consent from parent/guardian
- Warn parent/guardian that teeth may appear discoloured following varnish application
- If thick plaque deposits are present, clean the teeth first
- Dry teeth gently eg with gauze or cloth
- Apply fluoride varnish:
 - use a small brush, applicator or dental probe
 - apply as a thin film to all tooth surfaces including exposed root surfaces if present (ensure the tip/brush is not overloaded with varnish)
 - the colour of the varnish will assist you to know where to apply it
- The varnish will set in the presence of saliva and should not be disturbed or removed prematurely. Advise not to eat or drink for 30 minutes or brush teeth until the following morning
- Ensure clinical documentation includes all teeth/tooth surfaces to which fluoride varnish was applied and dosage

S4	Fluoride varnish (Duraphat®)		Extended authority ATSIHP/RIPRN	
RN must consult MO/NP				
ATSIHP may proceed if included in the scope of practice in the practitioner's practice plan				
RIPRN may proceed				
Form	Strength	Route	Dose	Duration
Liquid	0.4 g/0.4 mL 5% (single dose) 50 mg/1 mL (10 mL tube 5%)	Topical to teeth	Child 18 months–6 years up to 0.25 mL Child 6–12 years up to 0.4 mL > 12 years–adult up to 0.75 mL Use Duraphat® dosing card if not using single dose preparation	stat Then administer 6 monthly or 3 monthly if indicated Do not supply for self or parent administration
Offer CMI: Teeth may appear discoloured temporarily following application. Do not brush teeth on day of application - resume brushing the next morning. Eat soft foods for the rest of the day to minimise disruption of the varnish				
Note: Do not apply if ulcerative gingivitis or stomatitis to avoid discomfort for patient (contains alcohol). Do not leave fluoride varnish unattended when in use. Fluoride varnish is an S4 when used by clinicians other than dental practitioners				
Contraindication: Allergy to colophony (natural rosin) or sticking plaster; any episode of severe allergy or bronchial asthma that has required hospitalisation				
Management of associated emergency: Adverse reactions extremely rare. If occurs contact MO/NP or dentist. If ingestion of large amounts contact Poisons Information Centre ☎ 13 11 26				

5. Follow up

- Arrange re-call for review of oral health status and reapplication of fluoride varnish:
 - if low risk - every 6 months, if high risk - every 3 months

6. Referral/consultation

- Refer high risk and patients with obvious dental caries to dentist

HMP Mouth ulcers - adult/child

Background

- Ulcers persisting > 2 weeks are potentially serious¹
- Ulcers are common in teenagers and young adults. The most common mouth ulcer is recurrent aphthous stomatitis (unknown cause), which affects 5–60% of the general population^{2,3}

1. May present with

- Ulcer(s) in mouth

2. Immediate management Not applicable

3. Clinical assessment^{1,2}

- Ask about:
 - when did ulcer(s) appear, duration
 - is it recurring
 - does patient suspect the cause eg trauma from:³
 - biting tongue/cheek
 - thermal burn from eating or drinking food that is too hot/cold
 - poor fitting dentures/sharp or broken teeth
 - use of topical agents in mouth, oral rinses
 - pain or pins and needles/tingling sensation(s) in mouth or face
 - dry mouth - is cause known eg medicine side effect
 - fever
 - ulcers anywhere else on body
- Past history:
 - previous ulcer(s)
 - immunocompromised eg chemotherapy, malnutrition, HIV
 - STI history. See [STI/BBV assessment, p. 445](#) - consider syphilis and gonorrhoea:²
 - screen if appropriate
 - smoking, alcohol use
 - anaemia
 - diet, recent weight loss
- Do:
 - vital signs
 - inspect mouth, lips and tongue:
 - 1 or more ulcers
 - size, location, shape - oval/round or irregular
 - any pigmented lesions on the ulcer

4. Management²

- Most ulcers are self-limiting and heal within a few days
- If patient unwell/has other symptoms, consult MO/NP
- If poor fitting dentures or broken/sharp teeth, advise to see dentist at next clinic
- **If ulcer(s) recurring, or has persisted for > 2 weeks:**^{2,4}
 - refer to next MO/NP clinic for investigations ± biopsy for less common causes eg:
 - metabolic, dermatological, allergic, immunological, infectious or cancer

- **Symptom relief options:**²
 - chlorhexidine gluconate 0.2% mouthwash. See [Gum disease, p. 272](#) for instructions
 - topical anaesthetic⁵ eg Seda lotion®
 - salt water mouth rinses³
 - avoid acidic drinks (eg fruit juice or soft drink) and very spicy/sharp food
 - clean teeth properly
 - if needed, paracetamol or ibuprofen may help. See [Acute pain, p. 32](#)

S2		Lidocaine (lignocaine) (Seda lotion®)		Extended authority ATSIHP/IHW/IPAP
ATSIHP, IHW, IPAP and RIPRN may proceed				
RN may administer; for supply see RN supplying, p. 11				
Form	Strength	Route	Dose	Duration
Lotion	2.5% 15 mL	Topical	Dip cotton wool tip in lotion and apply to ulcer as needed. Max. every 2 hours	If not improving after 2 weeks, advise to see MO/NP
Offer CMI: Caution with hot drinks as numbness can result in burns				
Contraindication: Not for use in infants				
Management of associated emergency: Consult MO/NP. See Anaphylaxis, p. 82				6

5. Follow up

- Advise to be reviewed in 2 weeks. If not healed, advise to see MO/NP at next clinic

6. Referral/consultation

- Consult MO/NP/dentist as above. Consider telehealth consult with dentist

HMP Tooth abscess - adult/child

Recommend¹

- Antibiotics are not a substitute for dental treatment of a tooth abscess. The source of infection must be treated eg extraction of tooth, root canal treatment or surgical intervention

1. May present with^{1,2}

- Toothache
- Localised swelling (abscess) on gum (± pus) ±
 - facial swelling/pain
 - fever
 - bad breath
 - systemically unwell

2. Immediate management¹

- Maintain airway if compromised - do not lay flat
- Do vital signs:
 - **note:** oral T is unreliable for infections in the mouth
- Screen for [Sepsis, p. 64](#)

3. Clinical assessment^{1,2}

- Ask about:
 - facial pain/toothache
 - hot/cold sensitivity of teeth
 - fever
 - recurrent tooth abscess needing antibiotics
 - tooth decay, dental trauma, loose tooth
 - alcohol and drug use
- Do BGL
- Inspect:
 - mouth/gums - any soft tissue swelling, redness, pus, trauma, tooth decay
 - face - any redness, swelling, warm to touch
 - can patient open mouth, swallow, breathe well

4. Management¹

- If child consult MO/NP/dentist
- Offer analgesia - ibuprofen preferred.³ See [Acute pain, p. 32](#)
 - add paracetamol if needed
 - advise to take regularly, rather than as required, to achieve continuous pain relief
 - if severe pain in adult (not responding to above) consider oxycodone

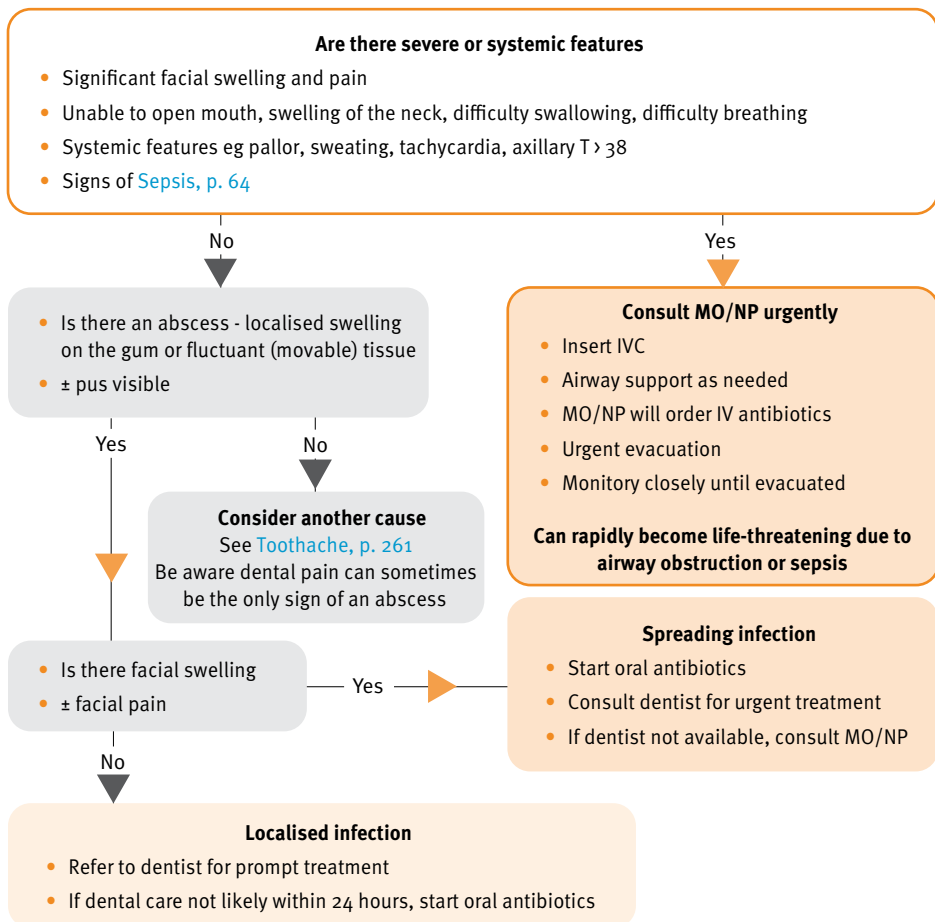
Tooth abscess management¹

Localised infection

- Refer to dentist for prompt treatment
- If dental care not likely within 24 hours, start oral antibiotics

- If oral antibiotics indicated, give:¹
 - amoxicillin + clavulanic acid OR
 - if allergy to penicillin, give clindamycin
- Consult MO/NP/dentist if the abscess is recurring/antibiotics have been given previously, but no dental treatment yet¹
- Advise patient:¹
 - to see dentist as soon as possible - the cause of the abscess/infection needs to be fixed
 - rinse mouth with warm sodium chloride 0.9% or chlorhexidine gluconate 0.2% mouthwash - as per [Gum disease, p. 272](#)
 - about good oral hygiene. See the *Chronic conditions manual* <https://www.health.qld.gov.au/rccsu/clinical-manuals/chronic-conditions-manual-ccm>

S4	Amoxicillin + clavulanic acid		Extended authority ATSIHP/IHW/IPAP/RIPRN	
ATSIHP, IHW and IPAP must consult MO/NP				
RN must consult MO/NP/dentist				
RIPRN may proceed				
Form	Strength	Route	Dose	Duration
Tablet	875 mg + 125 mg	Oral	Adult 875 mg + 125 mg bd	5 days
Oral liquid	400 mg + 57 mg/5 mL		Child 22.5 mg/kg (max. 875 mg) bd <i>Dose as per amoxicillin component</i>	
Offer CMI: Take with food. May cause rash, diarrhoea, nausea or thrush. Can cause severe diarrhoea (colitis) due to <i>C. difficile</i>				
Contraindication: Severe or immediate allergic reaction to a penicillin. Be aware of cross-reactivity between penicillins, cephalosporins and carbapenems				
Management of associated emergency: Consult MO/NP. See Anaphylaxis, p. 82				1,4

S4	Clindamycin		Extended authority ATSIHP/IHW/IPAP/RIPRN	
ATSIHP, IHW and IPAP must consult MO/NP				
RN must consult MO/NP/dentist				
RIPRN may proceed				
Form	Strength	Route	Dose	Duration
Capsule	150 mg	Oral	Adult 300 mg tds	5 days
			Child 7.5 mg/kg (max. 300 mg) tds	
Offer CMI: May cause rash, diarrhoea, nausea, vomiting or abdominal pain. Take with a full glass of water. Can cause severe diarrhoea (colitis) due to <i>C. difficile</i>				
Note: There is no oral liquid for children. For doses of a 'whole capsule' open the capsule and mix with a spoonful of food eg yoghurt or apple puree. For doses < 150 mg, open capsule and disperse contents into 10 mL of water to make a concentration of 15 mg/mL. Measure the required dose and give immediately. If smaller volumes are required, the capsule will disperse into 3 mL. The dispersion is highly unpalatable and may be mixed with juice before giving				
Contraindication: Allergy to clindamycin or lincomycin				
Management of associated emergency: Consult MO/NP. See Anaphylaxis, p. 82				1,5

5. Follow up

- Advise to return daily for review until it resolves or sooner if symptoms worsen
- Consult MO/NP/dentist if:¹
 - unresponsive to oral antibiotics after 48–72 hours
 - if deteriorating at any time - may need evacuation for surgical treatment and IV antibiotics

6. Referral/consultation

- Consult MO/NP/dentist as above. Consider telehealth consult with dentist

Post tooth extraction bleeding - adult/child

1. May present with¹

- Bleeding continuing or recurring after a tooth extraction

2. Immediate management

- Consult MO/NP/dentist urgently if:
 - bleeding causing swelling or airway compromise
 - patient is haemodynamically unstable. See [Shock](#), p. 62

3. Clinical assessment²

- **Ask about:**
 - when tooth was extracted
 - when bleeding started
 - nature and amount of blood loss - ooze or filling mouth with blood after dressing removed
 - has patient tried biting on gauze to stop bleeding
 - use of mouth washes; touching site with tongue/fingers - that could exacerbate bleeding
 - medical history, including:
 - medications that could increase bleeding eg warfarin, aspirin, heparin, complementary
 - does patient usually bleed or bruise after trauma
 - bleeding disorders eg haemophilia
 - leukaemia, chronic liver disease
 - alcohol use
- Do vital signs
- **Assess bleeding:**
 - sit patient up under good light
 - use gauze, suction or syringe with normal saline to remove blood, saliva and any liver clots (large mobile clots resembling fresh liver)
 - is blood continually filling mouth or just a sluggish ooze
 - any high flow arterial bleed, tear in gum or mucosa
 - any pus, cellulitis, trismus (unable to open mouth), liver clots

4. Management²

- Consult MO/NP/dentist if:
 - pus, cellulitis or trismus
- **To stop bleeding:**
 - dampen a piece of gauze, fold to postage stamp size, place on socket and hold firmly in place for 20 minutes until bleeding stops
 - if bleeding continues, rinse the socket with sodium chloride 0.9%, replace the gauze and ask patient to bite down firmly for 30 minutes
- **If bleeding continues despite measures above:**
 - consult MO/NP/dentist who may order:
 - gauze (as above) soaked in a 5% solution of tranexamic acid
 - make 5% solution by crushing a 500 mg tranexamic acid tablet and mix in 10 mL water
- **If bleeding continues beyond these measures, or low level ooze continues > 12–24 hours:**
 - systemic causes should be investigated - consult MO/NP/dentist

5. Follow up

- Advise patient to be reviewed the next day, or sooner if bleeding starts again
- Refer to next dentist clinic

6. Referral/consultation

- Consult MO/NP/dentist as above. Consider telehealth consult with dentist

HMP Dry socket - adult/child

Background¹

- Dry socket (alveolar osteitis) is when a blood clot disintegrates prematurely after a tooth/teeth extraction resulting in inflammation of the bone below

1. May present with¹

- Severe pain ± bad breath 1–4 days post tooth extraction

2. Immediate management Not applicable

3. Clinical assessment¹

- Ask about:
 - when tooth extraction occurred, pain
- Do vital signs
- Inspect tooth extraction site:
 - typically the socket appears grey, non healing and is often filled with debris

4. Management¹

- Offer analgesia - ibuprofen preferred.² See [Acute pain, p. 32](#)
 - add paracetamol if needed
 - advise to take regularly, rather than as required, to achieve continuous pain relief
 - if not effective, consider oxycodone (adult)
- Irrigate socket gently with warm sodium chloride 0.9% to remove debris
- Place Alvogyl® (antiseptic and analgesic) dressing loosely into socket:
 - does not require removal later. **Note:** do not use if allergic to iodine
 - if not available contact MO/NP/dentist for further advice
- Should heal spontaneously within 2–3 weeks
- If pain persists > 3 weeks, or signs (eg pain, redness) outside of the tooth socket, consult MO/NP/dentist for review of diagnosis

5. Follow up

- Advise patient to be reviewed daily initially. Redress the socket as needed
- Consult MO/NP/dentist if not improving
- Refer for next dentist clinic visit

6. Referral/consultation

- Consult MO/NP/dentist as above. Consider telehealth consult with dentist

HMP Gum disease - adult/child

Gingivitis, periodontitis, necrotising gingivitis

Background^{1,2}

- Gingivitis is inflammation of the gums caused by the presence of undisturbed plaque. If not managed appropriately, can lead to periodontitis (loss of bone/tissues that support the teeth)

1. May present with

Gingivitis¹

- Red, swollen gums that bleed easily
- Rarely painful

Periodontitis²

- Bad breath, bad taste
- Gum recession
- Bleeding ± swollen gums
- If severe, may have:
 - loose teeth, spaces between teeth
 - pain
 - abscess. See [Tooth abscess, p. 267](#) for management
- Rarely seen in children

Necrotising gingivitis³

- Bleeding gums, ulcers - may have grey membrane
- Significant pain
- Bad breath
- ± swollen lymph nodes, fever
- Most common in young adult smokers. Rarely seen in children

2. Immediate management Not applicable

3. Clinical assessment

- Get history, including:
 - smoking
 - diabetes
 - teeth brushing/oral hygiene/dental history
- Do vital signs + BGL
- Inspect lips, gums, teeth, tongue, lymph glands in neck

4. Management¹⁻³

- Offer analgesia as needed. See [Toothache, p. 261](#) for dental pain recommendations
- Consult MO/NP/dentist if:
 - severe ± systemic signs and symptoms eg fever, malaise
 - patient has an underlying medical condition eg poorly controlled diabetes, immunocompromised

In all cases^{1,2}

- Offer education on good oral hygiene. See the *Chronic conditions manual* <https://www.health.qld.gov.au/rccsu/clinical-manuals/chronic-conditions-manual-ccm>

Gingivitis¹

- Refer to dentist for check-up and clean - removal of plaque and calculus
- If pain limits ability to brush teeth/floss well:
 - consider short-term use of chlorhexidine gluconate 0.2% mouthwash
- Should resolve within 1 month

Periodontitis²

- If child consult MO/NP - needs **urgent paediatrician review** to investigate underlying cause²
- Refer to next dental clinic for removal of plaque and calculus + ongoing care
- Support patient to modify risk factors eg smoking, diabetes management²
- Antibiotics are rarely needed

Necrotising gingivitis³

- **Refer to dentist as soon as possible** - for debridement of plaque and calculus + ongoing care
- Give metronidazole + advise to use chlorhexidine gluconate 0.2% mouthwash until pain ↓
- Advise to stop smoking
- **Note:** antibiotics alone, without debridement by dentist + improvement of oral hygiene will usually lead to recurrence

Unscheduled	Chlorhexidine gluconate mouthwash			
ATSIHP, IHW, IPAP, RIPRN and RN may proceed				
Form	Strength	Route	Dose	Duration
Liquid	0.2%	Topical to mouth	Adult 10 mL 8–12 hourly Child 6–12 years 5 mL under adult supervision 8–12 hourly	5–10 days Rinse or gargle for 1 minute, then spit out
Offer CMI: Can cause altered taste, burning sensation, brown discolouration of teeth, tartar build up. Rarely severe allergy. Limit use to up to 2 weeks to minimise side effects				
Contraindication: Allergy to chlorhexidine - any route				
Management of associated emergency: Consult MO/NP. See Anaphylaxis, p. 82				1,3

S4	Metronidazole		Extended authority	
ATSIHP, IHW and IPAP must consult MO/NP				
RN must consult MO/NP/dentist				
RIPRN may proceed				
Form	Strength	Route	Dose	Duration
Tablet	200 mg 400 mg	Oral	Adult 400 mg bd	3–5 days
Offer CMI: Avoid alcohol while taking and for 24 hours after finishing the course. Take with food to reduce stomach upset. May cause nausea, anorexia, abdominal pain, vomiting, diarrhoea, metallic taste, dizziness or headache				
Management of associated emergency: Consult MO/NP. See Anaphylaxis, p. 82				3,4

5. Follow up

- If necrotising gingivitis advise to be reviewed daily until improving

6. Referral/consultation

- Consult MO/NP/dentist as above. Consider telehealth consult with dentist
- If diabetic, consider referral to diabetic educator

HMP Oral thrush - adult/child

Background¹

- Oral thrush (candidiasis) occurs relatively commonly in neonates and infants. It is otherwise uncommon in healthy individuals

1. May present with¹

- Oral discomfort
- Whitish plaques on the tongue or oral mucosa
- Severe cases may show ulceration ± inflammation at 1 or both corners of mouth
- In infants:²
 - irritability
 - poor feeding ± feeding refusal
 - white, lacy curd-like plaque in mouth

2. Immediate management Not applicable

3. Clinical assessment

- Get history, including:
 - **adult** - ask about risk factors eg:¹
 - smoking, dentures (cleaning routine), corticosteroid inhalers, poor oral hygiene
 - immunocompromised
 - medicines eg antibiotics, corticosteroids
 - **infant** - ask about:²
 - nappy rash
 - if breastfeeding - any nipple pain, burning/itching or cracked/red areolae
 - method of cleaning feeding equipment/other items that go in mouth eg dummies (can be a source of reinfection)
- Do vital signs
- Check:
 - mouth - any white or whitish-yellow plaques that may be difficult to remove, with the underlying area being raw or bleeding
 - infant's nappy area - any shiny red patches with satellite lesions³
 - mother's nipple area (if indicated from history) - any redness/cracked nipples

4. Management

- Consult MO/NP if:
 - child > 2 years
 - immunocompromised - needs specialist advice¹
 - severe, persistent or frequent episodes of thrush - needs further evaluation

- **Adult:**¹
 - if not related to denture use consult MO/NP/dentist who may advise:
 - miconazole, nystatin or amphotericin B lozenges
 - if related to denture use:¹
 - give miconazole or nystatin
 - advise to apply to the cleaned fitting surface of the dentures at least twice a day
 - at night, remove dentures, clean well with a liquid soap and soft toothbrush and place in a dry environment
 - encourage good denture hygiene eg see <https://www.betterhealth.vic.gov.au/health/conditionsandtreatments/dentures>
- **Infant and child < 2 years:**¹
 - give oral miconazole gel or nystatin
 - concurrently treat nipples of mother if breastfeeding (use oral miconazole gel)⁴
 - advise on correct cleaning of feeding equipment/dummies
 - provide support with breastfeeding + refer to child health nurse/midwife as needed

S3	Miconazole			Extended authority
ATSIHP, IHW, IPAP, MID, RIPRN and SRH may proceed RN may administer; for supply see RN supplying, p. 11				
Form	Strength	Route	Dose	Duration
Oral gel	2%	Oral	Adult and child > 2 years 2.5 mL qid (½ of measure supplied)	7–14 days
			Birth (at term)–2 years 1.25 mL qid (¼ of measure supplied) In babies use a clean finger (not spoon) to smear in front of mouth to avoid choking	Continue for 7 days after symptoms resolve
Offer CMI: Place in the mouth and on the tongue after feeding/food. Keep in mouth as long as possible before swallowing. May cause mild GI upset				
Contraindication: Use with warfarin, simvastatin, ergometrine				
Management of associated emergency: Consult MO/NP. See Anaphylaxis, p. 82				1,5

S3	Nystatin			Extended authority
ATSIHP, IHW, IPAP, MID, RIPRN and SRH may proceed RN may administer; for supply see RN supplying, p. 11				
Form	Strength	Route	Dose	Duration
Oral liquid	100,000 units/mL	Oral	Adult and child 1 mL qid	7–14 days Continue for several days after symptoms resolve
Offer CMI: Swish around the mouth for as long as comfortable before swallowing. Use after feeding/drinking or eating. May cause nausea, vomiting or diarrhoea				
Management of associated emergency: Consult MO/NP. See Anaphylaxis, p. 82				1,6

5. Follow up

- Advise to be reviewed if symptoms do not resolve within a few days

6. Referral/consultation

- Consult MO/NP/dentist/child health nurse/midwife as above

Eye problems

Eye assessment - adult/child

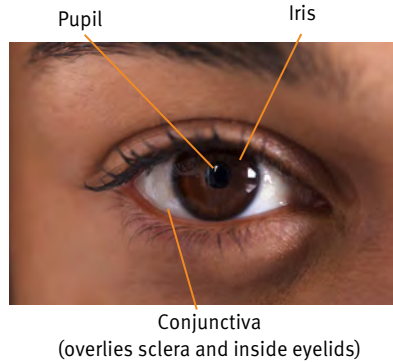
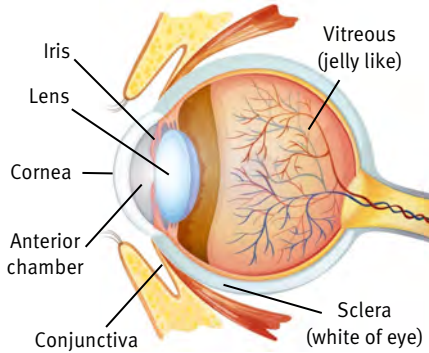

Eye tips¹

Do - when indicated

- Check visual acuity (VA) and record it
- Test pupil light reactions
- Evert the eyelid
- Stain with fluorescein to help identify a corneal defect, **unless** a ruptured eyeball or penetrating injury is obvious
- Advise not to drive with eye padded as depth perception may be altered

Don't

- Give local anaesthetic eye drops to take home
- Try to remove protruding foreign body (FB)
- Put drops or ointment in an eye that has suffered an obvious rupture or penetrating injury
- Use steroid eye drops or double pad an eye, unless advised by MO/NP/ophthalmologist
- Routinely apply eye pad

1. May present with

- Red, painful eye(s)
- Changes to vision, photophobia, blurred vision
- Discharge, tearing
- Feeling like something in eye

2. Immediate management

- If history of substance in eye(s):
 - irrigate eye(s) with **1–2 L** of sodium chloride 0.9% for ≥ 30 minutes:¹
 - tap water/shower if nothing else available^{2,3}
 - go to [Chemical burn to eye, p. 285](#)
- If protruding foreign body (FB) - **do not remove**:⁴
 - consult MO/NP urgently

3. Clinical assessment

- If severe pain, instil oxybuprocaine. See [FB in eye, p. 281](#) for drug box⁴
- **If injury/trauma**, ask about:
 - time and mechanism of injury eg sharp object, flash burn, exposure to laser

- **could there be a foreign body (FB):**
 - ask about all activities in preceding 24 hours
 - especially activities that can cause high velocity projectiles eg hammering metal, angle grinding, operation of high speed machinery⁵
 - possible contamination with plant material/soil
- use of protective eyewear
- if forceful blunt injury, suspect eyeball rupture ± ‘blow out’ fracture of the orbit
- **If child** always suspect injury as cause of red, painful eye:
 - were there any witnesses, is the injury consistent with explanation⁹
 - if non-accidental injury is suspected, also see [Child protection, p. 551](#)
- **Ask about symptoms:**
 - one or both eyes affected
 - rate of onset - sudden or over several hours^{6,7}
 - duration - is it getting better or worse
 - loss of vision, double or blurred vision⁶⁻⁸
 - photophobia, pain or grittiness, redness, discharge⁶⁻⁸
 - other eg flashing lights, floaters, headaches, halos around lights, fever
- **Get past history:**
 - diabetes, cold sores (herpes simplex virus), rheumatoid arthritis, ↑ BP
 - glasses, contact lenses (sleeping in, swimming in, prolonged use)^{6,8}
 - eye problems eg injury, cataracts, surgery
 - family history eg glaucoma
- Do vital signs
- Examine eye (see below)

Eye examination

- **If a red, swollen, tender eyelid + febrile** assume [Orbital/periocular cellulitis, p. 288](#)
- Examine systematically
- Use ophthalmoscope set to +10D and held at 10 cm from eye or bright pen light⁵
- Check both eyes without putting pressure on the eye or forcing the lids open, including:⁴
 - **eyelashes** - any in-turned, crusted discharge
 - **eyelids** - do they fully close, any lacerations, swelling, redness, bruising
 - **lower eyelid** - colour of conjunctiva
 - **sclera** - bleeding, FB
 - **cornea** - clear or hazy, FB, white spot¹
 - **anterior chamber** - any blood (hyphaema) or pus (hypopyon)
- If eye swollen closed, gently lift lid to check for injuries + pupil size and reaction to light

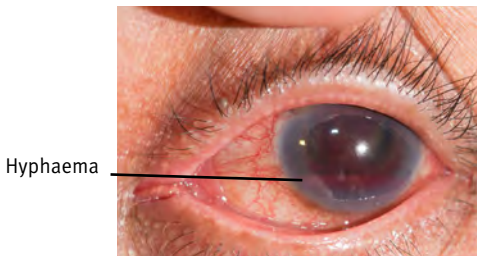

- **Always evert upper eyelid** if red eye, sensation of FB, or grittiness:
 - check for/exclude retained FB
 - + look for redness or small round bumps - may indicate conjunctivitis (bacterial, viral, allergic)
- **Examine the pupils + eye movements:**
 - check + compare pupils:
 - shape + reaction to light (do they react equally)
 - red reflex for any dimming, any cloudiness
 - any asymmetry in the position of and brightness of the corneal reflex
 - eye movements:
 - ask patient to look up, down, side to side - any pain
 - any restriction. If restricted upward movement consider orbital fracture in blunt injury
 - any double vision. To confirm if it is true double vision (and not just blur/ghosting), cover 1 eye. If double vision disappears, it is not true double vision
- **Do visual acuity (VA)**
 - **note:** 3/3 or 6/6 VA does not exclude a serious condition. ↓VA may be long-standing or due to uncorrected refractive error
 - repeat VA using a multiple-pinhole occluder if available. If vision improves it likely means a VA issue that can be corrected with glasses, and less likely an acute issue
- **Stain with fluorescein** to help identify a FB or corneal defect eg abrasion
- **Measure intraocular pressure (IOP)** if tonometer available and skilled

Visual acuity (VA)

- Use Snellen or tumbling E chart positioned at the specified distance eg 3 or 6 metres, from the patient in a well lit area:¹⁰
 - test one eye at a time
 - ask patient to cover one eye with their palm and read or point in the direction of the E's, from the top of the chart left to right
 - record VA as 2 numbers. Top number is the distance from the chart, bottom number is the smallest line of letters/Es that can be read without mistakes eg 3/3, 6/9
- If cannot read the top letter at 3 or 6 metres:¹⁰
 - hold up your fingers at varying distances eg 5 metres, 4 metres etc and record vision as counting fingers (CF) (the maximum distance they can see between 5 and 1 metre eg VA CF 5 m)
- If cannot see to count fingers, check if they can see hand movements or have perception of light by shining a torch into the eye at 10 cm⁵

Fluorescein examination of cornea (eye drops or strips)

- **Avoid** if obvious or high likelihood of globe rupture or penetrating injury
- If red eye(s) use separate strips/tissues for each eye¹
- **Fluorescein eye drops** - use smallest amount possible, too much will flood the eye and a defect may be missed.⁴ Gently dab the closed eye with a tissue to remove excess
- **Fluorescein strips** - gently touch the strip to the inside of the lower eyelid, pre-moisten with saline if dry eye. Repeat if more dye is needed
- Ask the patient to blink to spread the dye
- Dye will pool or 'uptake' (stain) in damaged areas of cornea
- In normal light uptake will look yellow. **With blue light of ophthalmoscope uptake will be green:**¹¹
 - **multiple pinpoint uptake** - may be dry eye
 - **sharp, well-defined border** - may be abrasion(s)
 - **round with fuzzy edges, branching (dendritic) pattern** - may be herpes simplex virus
 - **vertical lines on upper cornea** - may be retained FB in eyelid

How to evert an eyelid¹

Image 1



Ask patient to keep looking downwards as you take hold of the eyelashes and then gently pull the lid slightly towards you (image 1)

Image 2



Place cotton bud at the lid crease (or 5 mm from lid edge) and apply very light pressure downward with the bud (images 1 & 2)

Image 3



Evert the eyelid by using the eyelashes to gently pull the lid upwards over the bud. Remove the bud (image 3)

Reproduced with permission from NSW Department of Health. 2009. Eye emergency manual: an illustrated guide. 2nd ed

Eye differential diagnosis - adult/child

- Use flowchart below to help with differential diagnosis¹²
- **Be aware of the single red eye**

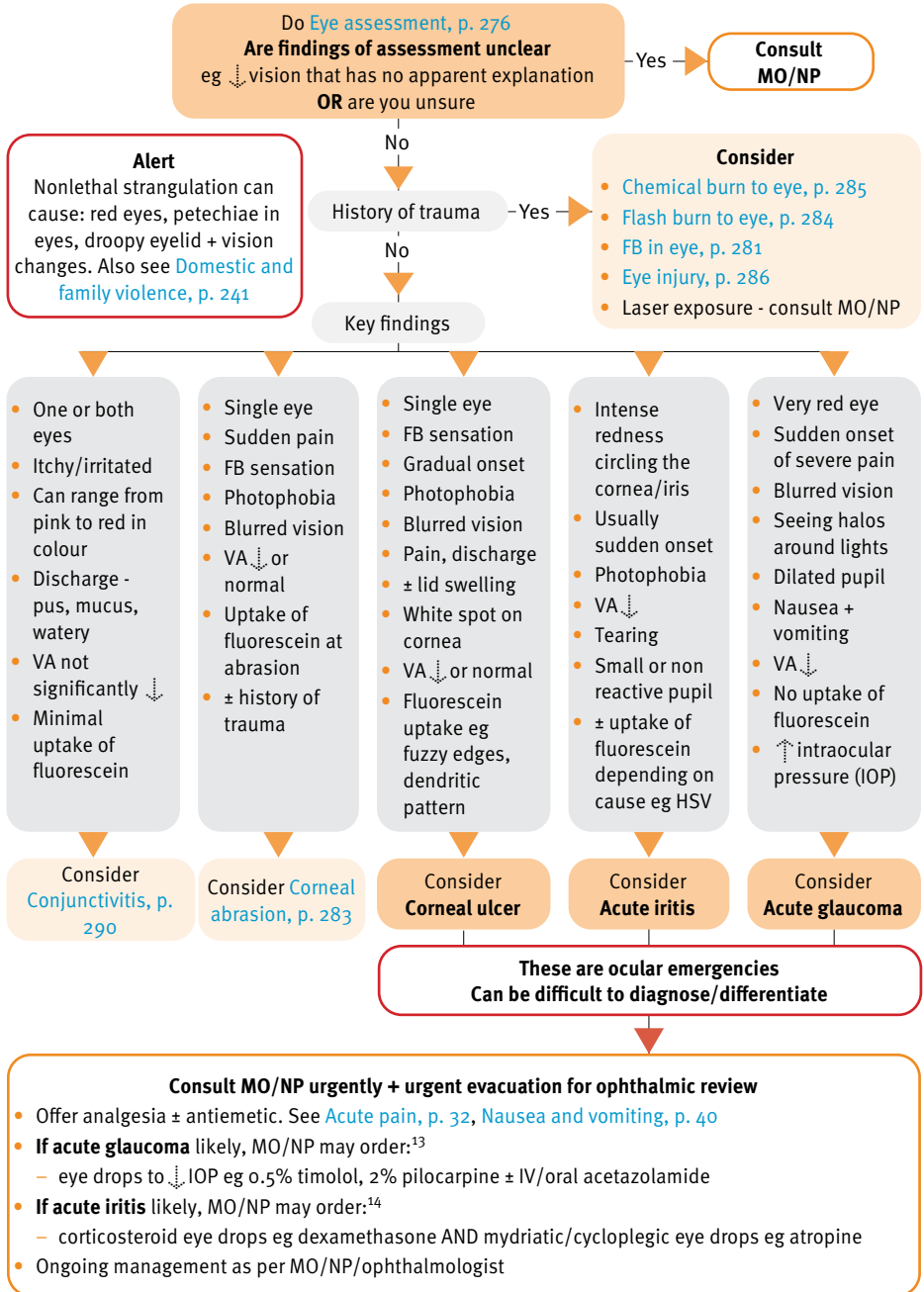

HMP Foreign body in eye - adult/child

1. May present with^{1,3}

- Report of something in the eye - pain/grittiness:
 - may be worse when blinking or with eye movements
- ± red, watery eye(s), swollen eyelid(s), photophobia

2. Immediate management

- See [Eye injury, p. 286](#) if:⁴
 - obvious penetrating injury, or caused from high speed and force (high velocity)
 - protruding foreign body (FB) - **do not remove**
- Advise to not rub the eye

3. Clinical assessment

- Ask about:
 - time + how FB happened eg:⁴
 - hammering metal, angle grinding, operation of high speed machinery - **high velocity**
 - sand, dust, eyelash^{1,3} - **low velocity**
 - if unsure, ask about all activities in preceding 24 hours, especially activities that can cause high velocity projectiles
 - use of protective eyewear^{1,3}
 - pain, changes in vision, photophobia^{1,3}
 - contact lenses - get patient to remove¹
 - previous eye conditions
- Do vital signs
- Examine both eyes as per [Eye assessment, p. 276](#)
 - instil oxybuprocaine if needed for pain¹
 - visual acuity (VA) - test unaffected eye first
 - evert eyelids:^{1,2}
 - if FB seen under eyelid, use moistened cotton tip with sodium chloride 0.9% to sweep away^{1,2}
 - stain with fluorescein - may help to see FB + show any [Corneal abrasion, p. 283](#)
- If unable to tolerate examination, contact MO/NP³

4. Management

- If no FB visible, but fluorescein shows abrasion on cornea, see [Corneal abrasion, p. 283](#)
- Consult MO/NP if:
 - high velocity projectile - x-ray may be needed
 - event happened a few days prior + there is ↑ pain, worsening vision + diffuse redness²
 - ↓VA, pupils irregular or non-reactive
 - blood in anterior chamber (hyphaema) - suggests perforation of eyeball
 - FB 'lodged' in the cornea
- Only try to remove the FB if it:
 - looks superficial/not 'lodged' in the eye
 - is at least 4 mm from the pupil

Removal of foreign body^{2,3}

- Lie patient down, with affected eye closest to you
 - Ask patient to look up, approach from side to ↓ blinking. Hold eyelid open if needed²
 - First try to irrigate with sodium chloride 0.9% (use a syringe without needle) FB may wash off²
 - Or, try to dislodge with a moistened cotton tip applicator using ‘dab’ or ‘nudging’ motion²
 - If still not dislodged, MO/NP may consider removal from cornea with 25 G needle (best done with slit lamp)⁴
 - Consider instilling oxybuprocaine in both eyes to stop blinking to aid removal
 - If unable to remove the FB, or there is a ‘rust ring’ after removal - consult MO/NP
- If FB removed from cornea give chloramphenicol as per [Corneal abrasion, p. 283](#)
 - Advise to wear protective eyewear during risky activities¹

S4	Oxybuprocaine	Extended authority ATSIHP/IHW/IPAP/RIPRN		
ATSIHP, IHW, IPAP and RN must consult MO/NP				
RIPRN may proceed				
Form	Strength	Route	Dose	Duration
Eye drops	0.4%	Eye	Adult and child 1 drop	stat Repeat in 1–2 minutes if needed Up to 6 drops may be used for foreign body removal
Offer CMI: May sting for a few seconds. Close eyes after instillation. Dab away tears, do not rub				
Note: Do not give to patient to take home				
Contraindication: Ruptured eyeball or penetrating eye injury				
Management of associated emergency: Consult MO/NP. See Anaphylaxis, p. 82				

5

5. Follow up

- If FB **removed from cornea**, advise to return the next day for review + stain with fluorescein:
 - consult MO/NP if VA ↓, pain or redness ↑, or defect on fluorescein staining
- For any **other FB**, advise to return if the sensation of FB in eye worsens or persists overnight:
 - consult MO/NP

6. Referral/consultation

- As above

HMP Corneal abrasion - adult/child

1. May present with^{1,2}

- Sudden pain + foreign body sensation - even if none is present ±
 - tearing, photophobia, blurred vision, difficulty opening eye, history of eye trauma

2. Immediate management Not applicable

3. Clinical assessment

- Get history and examine eyes as per [Eye assessment, p. 276](#)
- Do vital signs

4. Management

- **Consult MO/NP urgently if:**
 - suspected [Corneal ulcer, p. 280](#)
 - significant pain, photophobia, ↓ vision or worsening symptoms
 - wears contact lenses
- MO/NP may advise urgent evacuation for ophthalmology review ± topical antibiotics
- If abrasion < 4 mm + normal vision and resolving symptoms:³
 - give chloramphenicol¹
 - advise most heal in 1–2 days¹⁻³
 - do not patch or pad the eye⁴
- Offer ibuprofen.⁴ See [Acute pain, p. 32](#)

S3	Chloramphenicol			Extended authority ATSIHP/IHW/IPAP
ATSIHP, IHW and IPAP must consult MO/NP				
RIPRN may proceed				
RN may administer; for supply see RN supplying, p. 11				
Form	Strength	Route	Dose	Duration
Eye drops	0.5% (10 mL)	Eye	1 drop qid OR	3–5 days
Eye ointment	1%		1.5 cm of ointment qid	
Offer CMI: May cause stinging or burning. Discard one month after opening. Can be stored at room temperature once opened. Do not wear contact lenses during treatment				
Contraindication: Ruptured eyeball or penetrating injury				
Management of associated emergency: Consult MO/NP. See Anaphylaxis, p. 82				5,6

5. Follow up

- Advise to be reviewed daily until healed or sooner if symptoms worsen:
 - repeat VA, stain with fluorescein - consult MO/NP if worsening symptoms/no improvement
- Advise to see MO/NP at next clinic

6. Referral/consultation

- As above

HMP Flash burn to eye - adult/child

Background

- Damage to the cornea from excessive exposure to bright ultra violet (UV) light.¹ If left untreated infection can start, which can lead to loss of vision²

1. May present with²

- Intense pain/feeling that there is something in eye (usually both eyes)
- Exposure to UV light around 5–12 hours prior eg:¹
 - welding, direct sunlight, reflection off snow/water, sunlamp, lightning, explosion, solar eclipse
- Red, watery eye(s), closed eyelid(s)

2. Immediate management

- Offer analgesia. See [Acute pain, p. 32](#)

3. Clinical assessment

- **Ask about:**³
 - recent welding/other exposure to UV light
 - onset/duration of pain/symptoms¹
 - photophobia, blurred/changed vision
 - one eye or both
 - contact lenses - get patient to remove
 - has this happened before - ↑ risk of infection after previous injury/burn³
- Do vital signs
- **Examine both eyes** as per [Eye assessment, p. 276](#):
 - instil **single dose** of oxybuprocaine as per drug box [FB in eye, p. 281](#)
 - VA
 - stain with fluorescein - may show widespread dots (superficial defects) across the cornea, particularly where not protected by eyelids in normal position, often both eyes⁵
 - if from welding check for [FB in eye, p. 281](#)
- Check face/skin for burns⁴

4. Management^{4,5}

- Consult MO/NP if:
 - large or central (over pupil) corneal abrasion
 - VA ↓
- Treat as per [Corneal abrasion, p. 283](#)
- Advise the pain and discomfort should start improving in a few hours
- Usually heals in 1–2 days

5. Follow up

- As per [Corneal abrasion, p. 283](#)

6. Referral/consultation

- As above

HMP Chemical burn to eye - adult/child

Recommend

- Immediate irrigation is critical to avoiding permanent damage + blindness¹⁻³

1. May present with¹

- History of substance in eye(s) ±
 - pain
 - weeping, swelling of the lids or conjunctiva
 - ↓ vision
 - photophobia

2. Immediate management

- Irrigate eye(s) with 1–2 L of sodium chloride 0.9% for ≥ 30 minutes. Use:²
 - IV bag with giving set fully open **or**²
 - tap water/shower if nothing else available^{1,3}
 - **do not examine eye(s) until this has been done**
- Lie patient down, hold tubing 3–5 cm above eye surface, ask patient to:²
 - open eyelids as wide as possible - may need to hold eyelid open
 - look left, right, up + down while irrigating
 - if only one eye, tilt head away from unaffected eye
 - remove any foreign bodies - evert upper/lower eyelids + sweep with a soaked cotton tip^{1,3}
- Oxybuprocaine eye drops can be used for pain relief but remember if you are irrigating you are washing them out. Instil about every 10 minutes. See [FB in eye, p. 281](#) for drug box
- Offer analgesia if eye drops do not provide adequate pain relief. See [Acute pain, p. 32](#)
- **Urgently contact MO/NP**

3. Clinical assessment

- **Get rapid history while irrigating:**
 - when/how did it happen - if explosion may have other injuries¹
 - what was the chemical and active ingredients if possible. **Note:** alkalis burn deeper + require more irrigation eg lime, oven cleaner¹⁻³
 - any first aid, how soon after^{1,2}
 - photophobia
 - pain in or around the eye
 - vision changes
- Do vital signs
- **After 30 minutes of irrigation:**²
 - use litmus paper to check pH, touch the paper on inside lower eyelid
 - pH should be between 6.5–7.4
 - if not - keep irrigating + contact MO/NP
 - use Morgan Lens® if skilled
- **If pH 6.5–7.4 check:**¹
 - VA + stain with fluorescein
 - IOP if skilled
 - outer aspects of eye + lids for abnormalities:^{1,2}

- cornea clear or cloudy, can you see iris details²- cloudy may indicate severe burn¹
- evert lids again - any retained chemical^{2,3}
- check surrounding skin

4. Management

- Contact Poisons Information Centre ☎ 13 11 26 (24 hours)
- Consult MO/NP urgently, who will advise:
 - further management ± evacuation for ophthalmology review

5. Follow up

- As per MO/NP/ophthalmologist

6. Referral/consultation

- As above

HMP Eye injury - adult/child Blunt, penetrating

1. May present with^{1,3}

- Trauma ±
 - pain
 - loss of vision, double vision, photophobia
 - excessive tearing - if globe perforated, aqueous will leak out + look like excessive tearing

2. Immediate management

- Assess + treat life-threatening injuries⁴ eg [Head injuries, p. 143](#), [Traumatic injuries, p. 134](#)
- If obvious penetrating injury or protruding FB **do not remove - consult MO/NP urgently**^{2,5}

3. Clinical assessment

- Get history + do examination as per [Eye assessment, p. 276](#), including:
 - if blow to the eye/blunt injury eg fist, falls, sports - check for orbital fracture:^{3,4}
 - feel the bony rim above and below the eye - any deformity, pain
 - any numbness of the lower lid, cheek, side of nose, upper lip, teeth³
 - if the eye looks displaced lower than other eye or is turning out - may indicate a blow out fracture
 - **note:** if using fluorescein, also look for the Seidel sign - where the aqueous leaking out of a perforating injury causes an expanding dark patch to form in the fluorescein pattern
- If suspected penetrating injury, check tetanus status² ± give [Tetanus immunisation, p. 557](#)
- Do vital signs

4. Management

- **If ruptured eyeball or penetrating injury cannot be ruled out:**^{2,5}
 - consult MO/NP urgently
 - protect by taping rigid eye shield over eye:²
 - if no eye shield use cut down Styrofoam® cup taped securely to the brow + cheek
 - make sure the shield/cup is not pressing on the eye
 - bed rest on back, with head elevated if preferred, in dim lighting⁴

- keep nil by mouth^{2,5}
- Consult MO/NP in all cases, who may advise:
 - antibiotics, x-ray
 - urgent evacuation for ophthalmic review ± CT scan/MRI if suspected intraocular FB:
 - if risk of trapped air from penetrating injury, sea level cabin pressure is required for flight
- Offer analgesia ± antiemetic. Nausea and vomiting can ↑ injury.^{2,5} See [Acute pain, p. 32](#), [Nausea and vomiting, p. 40](#)

5. Follow up

- If not evacuated advise follow up as per MO/NP/ophthalmologist

6. Referral/consultation

- As above

Sudden, painless loss of vision - adult/child

Background¹

- This is an emergency. Causes can include - stroke, TIA, blockage in eye vessel, retinal detachment

1. May present with

- Sudden loss of vision - partial or complete in 1 or both eyes

2. Immediate management

- If loss of vision + signs of stroke eg one sided weakness, slurred speech:^{1,2}
 - contact MO/NP urgently
 - see [Stroke, p. 130](#)

3. Clinical assessment^{1,3}

- **Get rapid history/assessment** as per [Eye assessment, p. 276](#)
- **Also ask:**
 - how quick did the vision go - sudden, over several minutes or hours
 - 1 or both eyes - 1 usually means ocular cause; both usually systemic disease
 - has vision returned - may indicate TIA/vascular cause
 - other symptoms - any:
 - preceding flashes ± floaters, or recent facial trauma - may indicate retinal detachment
 - double vision, 'dark shadow' in vision of affected eye
 - jaw pain on chewing - may indicate temporal arteritis
 - prior episodes
 - contact lenses/glasses
 - hypertension, diabetes, cataract surgery
 - current medicines, eye drops
- Vital signs + BGL
- Examine eyes, including:
 - VA (distance + near) + pupil reaction to light
 - visual field, eye movements
 - red reflex - loss of reflex may indicate retinal detachment

4. Management

- Consult MO/NP urgently for all cases:
 - ongoing management ± urgent evacuation for specialist review/management
- Minimise activity eg bed rest³

5. Follow up

- As per MO/NP

6. Referral/consultation

- As above

HMP Orbital/periorbital cellulitis - adult/child

Background

- Orbital cellulitis is an infection of the eye socket + surrounding tissue. **It is an emergency + can cause blindness** + intracranial infection¹
- Periorbital cellulitis is an infection of the eyelid¹
- Overlapping clinical features makes it difficult to differentiate²
- Children < 4 years are at ↑ risk of both due to a undeveloped orbital septum¹

1. May present with

- Single eye with:²
 - swelling + redness of eyelid
 - eye pain or tenderness

2. Immediate management

- Do vital signs
- Screen for [Sepsis, p. 64](#)

3. Clinical assessment

- **Get rapid history:**^{1,2}
 - pain - eye, ear, facial
 - fever, malaise
 - headache - severe or persistent
 - ↓ vision, double vision
 - recent stye, trauma or insect bite to eye/eyelid
 - [Bacterial sinusitis, p. 252](#), tooth or ear infection³
 - Hib immunisation history
- **Check** head + neck, look for obvious signs of infection eg:
 - insect bite to the eye, wound, stye, infected tooth, enlarged lymph nodes, tender sinuses³
- **Examine** both eyes. Check for:¹⁻³
 - degree of swelling, reduced eye opening - does this limit your ability to examine the eye
 - painful/limited eye movements - unable to look in different directions
 - ↓ VA, pupil reaction to light not equal
 - protrusion of the eyeball

4. Management

- If both eyes are swollen, or non-tender (painless) swelling in a well looking patient, more likely to be an allergic reaction.² Consult MO/NP
- **Contact MO/NP urgently** in all other cases, who may advise:
 - if periorbital cellulitis likely AND patient otherwise well eg no fever, malaise:
 - oral antibiotics
 - if orbital cellulitis OR severe periorbital cellulitis suspected:
 - insert IVC
 - blood cultures, FBC^{1,2}
 - IV antibiotics
 - urgent evacuation ± CT scan¹
 - urgent ENT + ophthalmology advice
- Offer analgesia. See [Acute pain, p. 32](#)

Antibiotics¹ - MO/NP may order:

- If remote community in North Qld, NT, WA **OR** if previous MRSA infection/endemic setting:
 - oral trimethoprim + sulfamethoxazole (PLUS IV cefotaxime if severe)
- If non remote community **and NO** prior history of MRSA infection:
 - oral flucloxacillin (cefalexin if mild allergy, clindamycin if immediate sensitivity) OR
 - oral amoxicillin + clavulanic acid (if features of sinusitis, cefalexin if mild allergy)

S4	Trimethoprim + sulfamethoxazole			Extended authority ATSIHP/IHW/IPAP
ATSIHP, IHW, IPAP, RIPRN and RN must consult MO/NP				
Form	Strength	Route	Dose	Duration
Tablet	80 + 400 mg 160 + 800 mg	Oral	Adult 160 + 800 mg bd	7 days
Oral liquid	40 + 200 mg/5 mL		Child ≥ 6 weeks 4 mg/kg (max. 160 mg) bd <i>Dose as per trimethoprim component</i>	
Offer CMI: Take with food to reduce stomach upset. May cause fever, nausea, vomiting, diarrhoea, itch, rash or sore mouth. Avoid sun exposure. Report straight away if sore throat, fever, rash, cough, breathing difficulties, joint pain, dark urine or pale stools				
Note: If renal impairment, taking ACE inhibitor or potassium, HIV or SLE seek MO/NP advice				
Pregnancy: Do not use in the 1st trimester or in late pregnancy				
Contraindication: Severe or immediate allergic reaction to sulfonamides, megaloblastic anaemia, severe hepatic impairment, elderly				
Management of associated emergency: Consult MO/NP. See Anaphylaxis, p. 82				^{1,4}

S ₄	Cefotaxime			Extended authority ATSIHP/IHW
ATSIHP, IHW, RIPRN and RN must consult MO/NP				
Form	Strength	Route	Dose	Duration
Injection	1 g	IV	> 16 years to adult	stat Inject slowly over at least 3–5 minutes
	2 g		Infant and child ≤ 16 years 50 mg/kg (max. 2 g)	
Offer CMI: May cause diarrhoea, nausea, vomiting, pain at injection site, rash, headache or dizziness. Can cause severe diarrhoea (colitis) due to <i>C. difficile</i>				
Note: Rapid injection < 1 minute can cause life-threatening arrhythmias. If renal impairment advise MO/NP				
Contraindication: Severe hypersensitivity to penicillins, carbapenems and cephalosporins. Do not mix with aminoglycosides eg gentamicin				
Management of associated emergency: Consult MO/NP. See Anaphylaxis, p. 82 1,5				

5. Follow up

- If not evacuated, advise to be reviewed daily until improved or sooner if symptoms worsen:
 - if not improving after 24 hours, contact MO/NP
- Advise to see MO/NP at next clinic

6. Referral/consultation

- As above

HMP Conjunctivitis - adult/child

Related topics

[Eye differential diagnosis, p. 280](#)

1. May present with^{1,2}

- Itchy/irritated ± red eye(s)
- Discharge - watery, pus, mucous
- Crusting of eyelids/eye lashes

2. Immediate management Not applicable

3. Clinical assessment

- **Ask about:**^{1,2}
 - pain, photophobia or changes in vision
 - onset/duration of symptoms
 - one eye or both
 - contact with person with red eyes/conjunctivitis
 - recent URTI, sinusitis, flu-like symptoms
 - hay fever, known allergies
 - contact lenses
 - vesicular rash, cold sores, shingles

- exposure to irritants eg smoke or chlorine - usually self-limiting. If chemical exposure, also see [Chemical burn to eye, p. 285](#)
- Do vital signs
- Check for swollen glands in neck - may indicate viral conjunctivitis
- Examine both eyes as per [Eye assessment, p. 276](#) including:
 - VA + stain with fluorescein
 - evert eyelids - small round bumps under eyelid may indicate allergic conjunctivitis
- Use flow chart for further assessment¹

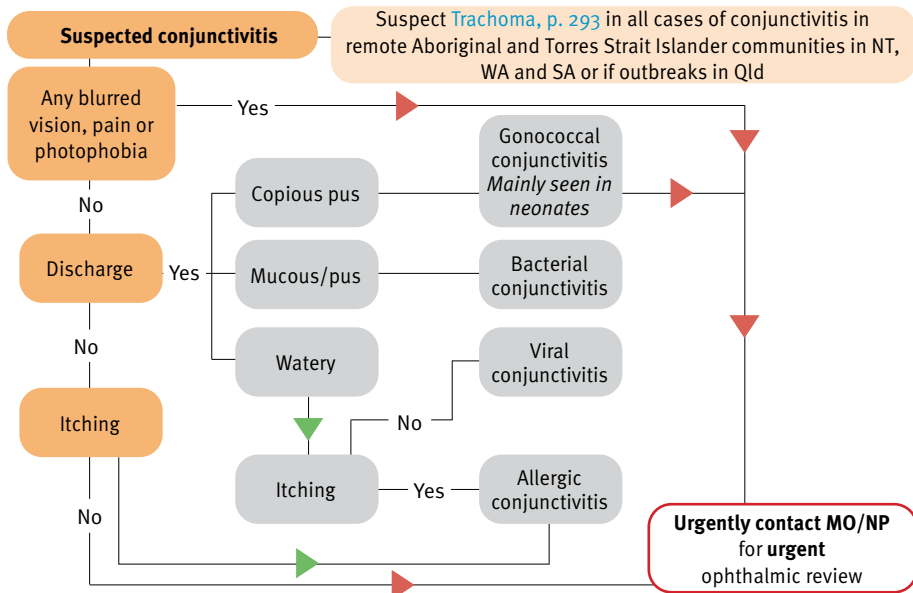

4. Management

- Contact MO/NP urgently if:²
 - pain, photophobia or reduced vision, or worsening symptoms
 - fluorescein uptake shows [Corneal abrasion, p. 283](#)
 - wears contact lenses, or has herpes/shingles infection

Newborn and young infant

- **2–12 months:**
 - if sticky/watery discharge is the ONLY symptom (no redness):
 - likely blocked tear duct rather than conjunctivitis²
 - usually gets better without treatment
 - seek advice from midwife/child health nurse/MO/NP as needed
 - if other signs of conjunctivitis eg red eye(s):
 - consult MO/NP
 - if suspected bacterial conjunctivitis give chloramphenicol²
- **Neonate:**
 - consult MO/NP
 - do swabs for MCS + gonorrhoea and chlamydia PCR:
 - if **gonorrhoea - ophthalmic emergency**² - consult MO/NP urgently
 - if **chlamydia** - MO/NP may order azithromycin²

- treat mother + contact tracing. See [STI/BBV, p. 445](#)
- if suspected bacterial conjunctivitis, MO/NP will order chloramphenicol
- **note:** chlamydia/gonorrhoea in neonate may reflect mother-to-child transmission, accidental transmission or sexual abuse.² See [Child protection, p. 551](#) if concerns

Child and adult

- **Viral conjunctivitis:**
 - usually in one eye, but often spreads to both
 - reassure patient usually self-limiting but may take weeks to resolve
 - do not give chloramphenicol²
 - lubricating eye drops may provide symptomatic relief
- **Allergic conjunctivitis:**
 - if patient has [Allergic rhinitis, p. 248](#) oral antihistamines may help²
 - antihistamine eye drops eg ketotifen, may help reduce symptoms and lubricating eye drops may help to remove allergen¹
- **Bacterial conjunctivitis:**
 - most cases will resolve in 7 days without treatment²
 - if marked symptoms eg purulent discharge, give chloramphenicol²
- **Chlamydial conjunctivitis:**
 - consider if sexually active with one red eye + mucopurulent discharge, or chronic conjunctivitis:¹
 - do [STI/BBV tests, p. 448](#) + swab eye for chlamydia PCR (write 'eye' on pathology form)
 - give oral azithromycin
- **In all cases:**
 - symptomatic treatment may help eg:
 - cold compresses several times/day or ice packs¹
 - clean eye(s) as needed with clean water to remove crusting and discharge. Gently wipe from inside to outside to avoid spreading infection to other eye³
 - frequent hand washing
 - avoid sharing towels, pillows
 - keep children away from school/child care until no discharge⁴

S3	Chloramphenicol			Extended authority ATSIHP/IHW/IPAP
ATSIHP, IHW and IPAP must consult MO/NP				
RIPRN may proceed				
RN may administer; for supply see RN supplying, p. 11				
Form	Strength	Route	Dose	Duration
Eye drops	0.5% (10 mL)	Eye	1 drop every 2 hours while awake for 1–2 days. Then, if improvement, 1 drop qid Use eye ointment at night (1–1.5 cm)	Up to 5 days
Eye ointment	1%		OR 1.5 cm of ointment 3–4 times daily	
Offer CMI: May cause stinging or burning. Discard one month after opening. Can be stored at room temperature once opened. Do not wear contact lenses during treatment				
Note: Consult MO/NP if child ≤ 2 years + not responding to treatment				
Management of associated emergency: Consult MO/NP. See Anaphylaxis, p. 82				2,5

S4	Azithromycin		Extended authority ATSIHP/IHW/IPAP/RIPRN	
ATSIHP, IHW, IPAP and RN must consult MO/NP				
RIPRN may proceed for adult only - must consult MO/NP for child and neonate				
Form	Strength	Route	Dose	Duration
Tablet	500 mg	Oral	Adult 1 g	stat
Oral liquid	200 mg/5 mL		Child > 1 month 20 mg/kg (max. 1 g)	
			Neonate 20 mg/kg daily	3 days
Offer CMI: May cause rash, diarrhoea, nausea, abdominal cramps or thrush. In neonates, advise parents to report if starts vomiting or irritable when feeding				
Note for neonates: Infantile hypertrophic pyloric stenosis has been associated with use of azithromycin, particularly during the first 2 weeks of life, with no increased risk after 7 weeks of age				
Management of associated emergency: Consult MO/NP. See Anaphylaxis, p. 82				2,6

5. Follow up

- Advise to return if worsening or new symptoms. Contact MO/NP who may:
 - order bacterial + viral swabs
 - arrange ophthalmic referral to exclude alternative diagnoses
- If bacterial and not resolved in 5 days, patient should have immediate ophthalmic review¹

6. Referral/consultation

- As above

HMP Trachoma - adult/child Chlamydia trachomatis conjunctivitis

Background

- Caused by *Chlamydia trachomatis*, different strains from the STI chlamydia. Repeated infections can lead to eyelid contraction and in-turned eyelashes that rub on the eyeball, causing painful corneal scarring and opacity. Can lead to blindness in older adults¹
- Most cases occur in children + teenagers in remote communities in the NT, SA and WA - with only **rare cases detected in Qld**¹
- Also see World Health Organisation *Trachoma* https://www.who.int/health-topics/trachoma#tab=tab_1

1. May present with^{1,2}

- Child - repeated conjunctivitis
- Adult - in-turned eyelashes, cloudy cornea

2. Immediate management Not applicable

3. Clinical assessment

- Get history, including:^{1,2}
 - previous episodes for patient and family

- time spent in NT, SA, WA or known area of outbreak
- contact with person(s) with similar symptoms
- Do vital signs
- Examine eyes as per [Eye assessment, p. 276](#), including:
 - evert the upper eyelids, look for:²
 - ≥ 5 pale round spots (follicles)
 - intense redness, swelling - can you see normal blood vessels
 - **note:** follicles ± intense redness are indications of active trachoma - take eyelid swab for chlamydia PCR
 - visible scarring, in-turned eyelashes, signs of pulling out eyelashes
 - check cornea - clear or cloudy

4. Management

- If highly suggestive of active trachoma, treat as per CDNA *Trachoma guidelines* <https://www1.health.gov.au/internet/main/publishing.nsf/Content/cdna-song-trachoma.htm>
 - treat patient and people > 3 kg who live in the same household(s) as the patient:²
 - give oral azithromycin
 - **note:** aim to treat all members of relevant household(s) within 1 week of starting treatment²
- Consult MO/NP if in-turned eyelashes:
 - referral for ophthalmic review ± eyelid surgery
- Advise patient and family to reduce spread of infection by:^{1,2}
 - daily showering, washing faces + hands regularly
 - avoid sharing towels/face washers, beds/bedding

S ₄	Azithromycin			Extended authority ATSIHP/IHW/IPAP/RIPRN
ATSIHP, IHW, IPAP and RN must consult MO/NP				
RIPRN may proceed				
Form	Strength	Route	Dose	Duration
Tablet	500 mg	Oral	Adult 1 g	stat
Oral liquid	200 mg/5 mL		Child > 3 kg 20 mg/kg (max. 1 g)	
Offer CMI: May cause rash, diarrhoea, nausea, abdominal cramps or thrush				
Management of associated emergency: Consult MO/NP. See Anaphylaxis, p. 82				2,3

5. Follow up

- Check swab result:
 - if *Chlamydia trachomatis* is identified notify Public Health Unit¹
- Advise to return if worsening or new symptoms, contact MO/NP who may:
 - order swabs for MCS and *Chlamydia trachomatis* PCR
 - arrange ophthalmic referral if repeated infections, in-turned eyelashes or corneal changes

6. Referral/consultation

- As above
- *Chlamydia trachomatis* is a notifiable disease by pathological diagnosis ①

Urinary tract problems

HMP Urinary tract infection (UTI) - adult Cystitis, pyelonephritis

Background

- The safety and efficacy of urinary alkalisers eg Ural®, Citravescent® is unknown¹
- Cranberry and ascorbic acid are not effective treatments²

1. May present with

Cystitis²⁻⁴

- Urinary symptoms - frequency, urgency, dysuria, haematuria
- Low abdominal pain
- Nitrites ± leucocytes on urinalysis

Pyelonephritis⁴

- T ≥ 38, flank pain, nausea, vomiting
- ± urinary symptoms

2. Immediate management

- Consider [Ectopic pregnancy, p. 371](#) in sexually active females with low abdominal pain
- Do vital signs
- Screen for [Sepsis, p. 64](#)

3. Clinical assessment^{3,4}

- **Ask about:**
 - past episode(s) of UTI and STI:
 - when, treatment, effectiveness
 - kidney stones, prostate problems, urinary tract abnormalities
 - vaginal discharge
- **Do:**
 - urinalysis
 - MSU for MCS if:
 - nitrites or leucocytes on urinalysis **or**
 - recently taken antibiotics or recurrent infection² **or**
 - if pyelonephritis is suspected
 - pregnancy test if female of reproductive age
 - check for any suprapubic, loin tenderness
 - if sexually active offer [STI/BBV tests, p. 448](#)

4. Management

- If pregnant see [UTI in pregnancy, p. 375](#)

Pyelonephritis⁴

- Contact MO/NP promptly who may advise:
 - IV gentamicin + ampicillin
 - check previous urine pathology results to ensure no resistance to antibiotics recommended
 - evacuation/hospitalisation

Cystitis

- Diagnosis requires the presence of symptoms (+ve urine culture alone does not require antibiotics)
- Offer paracetamol or ibuprofen. See [Acute pain, p. 32](#)
- Advise to drink enough fluids so not thirsty, aim for 6–8 glasses of water/day³
- **Male:**²
 - contact MO/NP
 - UTIs are uncommon - dysuria in younger males is usually caused by an STI
- **Female:**
 - if low abdominal pain **without** urine symptoms consider [PID, p. 462](#)
 - if nitrites or leucocytes on urinalysis AND:
 - **no urine symptoms** - MSU and antibiotics are not required⁵
 - **has urine symptoms** - do MSU + give antibiotics²

Antibiotics if indicated

- Trimethoprim OR nitrofurantoin. If contraindicated, give cefalexin:
 - **note:** give nitrofurantoin if treated \leq 3 months ago with trimethoprim²
 - check previous urine samples to ensure no resistance to antibiotics recommended. If resistance, contact MO/NP

S ₄	Trimethoprim			Extended authority ATSIHP/IHW/IPAP/RIPRN/SRH
ATSIHP, IHW, IPAP and RN must consult MO/NP				
RIPRN and SRH may proceed for females. Must consult MO/NP for males				
Form	Strength	Route	Dose	Duration
Tablet	300 mg	Oral	300 mg daily	Female 3 days Male 7 days
Offer CMI: Take at night to maximise urinary concentration. May cause fever, itch, rash or nausea				
Note: If renal impairment or on an ACEI, seek MO/NP advice. Elderly may be more susceptible to adverse effects eg hyperkalaemia				
Pregnancy: Avoid in 1st trimester				
Contraindication: Megaloblastic anaemia				
Management of associated emergency: Consult MO/NP. See Anaphylaxis, p. 82				

2,6

S ₄	Nitrofurantoin		Extended authority ATSIHP/IHW/IPAP/RIPRN/SRH	
ATSIHP, IHW, IPAP and RN must consult MO/NP				
RIPRN and SRH may proceed for females. Must consult MO/NP for males				
Form	Strength	Route	Dose	Duration
Capsule	50 mg 100 mg	Oral	100 mg qid	Female 5 days Male 7 days
Offer CMI: Take with food or milk to reduce nausea + improve absorption. May cause nausea, vomiting, headache, drowsiness or dizziness. Report if develop difficulty breathing, cough or numbness or tingling. May turn urine a brownish colour. Do not use with urinary alkalisers (eg Ural®, Citravescent®) as they reduce the antimicrobial effect				
Contraindication: Renal impairment				
Management of associated emergency: Consult MO/NP. See Anaphylaxis, p. 82 2,7				

S ₄	Cefalexin		Extended authority ATSIHP/IHW/IPAP/RIPRN/SRH	
ATSIHP, IHW, IPAP and RN must consult MO/NP				
RIPRN and SRH may proceed for females. Must consult MO/NP for males				
Form	Strength	Route	Dose	Duration
Capsule	250 mg 500 mg	Oral	500 mg bd	Female 5 days Male 7 days
Offer CMI: May cause rash, diarrhoea, nausea, vomiting, dizziness, headache or thrush				
Note: If renal impairment seek MO/NP advice				
Contraindication: Severe or immediate allergic reaction to a cephalosporin or a penicillin. Be aware of cross-reactivity between penicillins, cephalosporins and carbapenems				
Management of associated emergency: Consult MO/NP. See Anaphylaxis, p. 82 2,8				

5. Follow up²

- Advise to be reviewed in 2–3 days if still has symptoms, or sooner if concerned:
 - consult MO/NP if symptoms persist or worsen
- Check results of MSU:
 - if pathogen resistant to the antibiotics given, but **symptoms have improved**, do not give a different antibiotic²
 - consult MO/NP if pathogen resistant to antibiotics given and symptoms **have not improved**

6. Referral/consultation

- As above

Skin problems

HMP **Impetigo** - adult/child Infected skin sores, school sores, infected scabies

Recommend¹

- Treat impetigo promptly
- Promote prevention - hand washing with soap at least once a day, showering, washing clothes

Background^{1,3}

- Impetigo is a highly contagious skin infection, most common in children. If untreated can result in bone and joint infections, abscesses, cellulitis and sepsis
- Usually caused by Group A Strep in remote Aboriginal and Torres Strait Islander settings. Group A Strep can cause [APSGN, p. 511](#) and [ARF, p. 515](#) which can result in chronic kidney disease or rheumatic heart disease¹

1. May present with¹

- Sores from a break in skin that gets infected eg from:
 - scratching, [Scabies, p. 316](#), insect bites, [Head lice, p. 319](#) or [Tinea/ringworm, p. 311](#)
 - cuts and lacerations
- Sores start as round or oval filled bumps:
 - progress into blisters, or
 - produce a clear honey-coloured fluid that forms a crust on the skin
 - when the crusts are removed, the area underneath is red and eroded

2. Immediate management Not applicable

3. Clinical assessment¹

- Get history, including:
 - previous impetigo - when, treatment
- Do physical examination, including:
 - vital signs
 - weight - bare weight if < 2 years
 - urinalysis
 - examine skin. See [Skin assessment - adult, p. 21](#) or [Skin assessment - child, p. 485](#)
 - look for signs of [Scabies, p. 316](#)
 - assess for signs of systemic infection eg fever, malaise and sequelae eg [APSGN, p. 511](#) or [ARF, p. 515](#), [Sepsis, p. 64](#), [Cellulitis, p. 306](#), [Septic arthritis, p. 550](#)
- Take swab for MCS before starting antibiotics.³ See [How to take a wound swab, p. 324](#)

4. Management

- Consult MO/NP if:
 - BP or urinalysis is abnormal - may indicate the presence of [APSGN, p. 511](#)
 - systemically unwell eg fever, malaise
- **Give antibiotics for anyone with impetigo, regardless of severity^{1,3}**
- If present, treat [Scabies, p. 316](#) or [Head lice, p. 319](#) concurrently

Antibiotics for impetigo^{1,3}

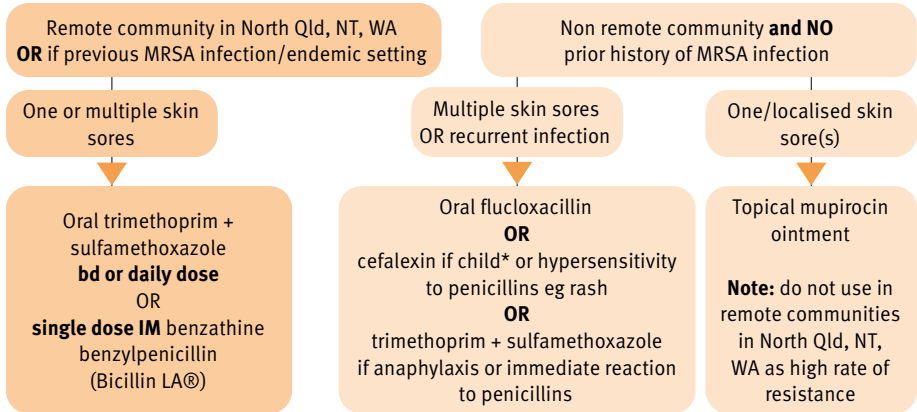

*If unable to swallow capsules, as cefalexin liquid tastes better than flucloxacillin liquid

Advice to parent/carer^{1,2}

- Wash hands regularly with soap or alcohol based hand sanitiser. Ask others in the household to do the same
- Try not to touch the sores
- Have regular showers/bathing
- If needed, wash sores with soap and water
- Don't share towels
- Cover sores on exposed areas with waterproof dressing, until sores are dry⁴
- Keep home from school/child care until 24 hours of antibiotics have been given⁴

S4	Trimethoprim + sulfamethoxazole		Extended authority ATSIHP/IHW/IPAP/RIPRN	
ATSIHP, IHW, IPAP and RN must consult MO/NP				
RIPRN may proceed				
Form	Strength	Route	Dose	Duration
Tablet	80 + 400 mg 160 + 800 mg	Oral	bd dose preferred Adult 160 + 800 mg Child ≥ 1 month 4 mg/kg (max. 160 mg)*	bd for 3 days OR daily for 5 days
Oral liquid	40 + 200 mg /5 mL		daily dose eg daily supervised Adult 320 + 1600 mg Child ≥ 1 month 8 mg/kg (max. 320 mg)*	
*Dose as per trimethoprim component				
Offer CMI: Take with food to reduce stomach upset. May cause fever, nausea, vomiting, diarrhoea, itch, rash or sore mouth. Avoid sun exposure. Report straight away if sore throat, fever, rash, cough, breathing difficulties, joint pain, dark urine or pale stools				
Note: If renal impairment, taking ACE inhibitor or potassium, HIV or SLE seek MO/NP advice				
Pregnancy: Do not use in the 1st trimester or in late pregnancy				
Contraindication: Severe or immediate allergic reaction to sulfonamides, megaloblastic anaemia, severe hepatic impairment, elderly				
Management of associated emergency: Consult MO/NP. See Anaphylaxis, p. 82				

1,2

S4	Benzathine benzylpenicillin (Bicillin LA®)			Extended authority ATSIHP/IHW/IPAP/RIPRN		
ATSIHP, IHW, IPAP and RN must consult MO/NP						
RIPRN may proceed						
Form	Strength	Route	Dose			Duration
Prefilled syringe	1.2 million units/ 2.3 mL	IM	< 10 kg	450,000 units	0.9 mL	stat Inject slowly over at least 2–3 minutes
			10– < 20 kg	600,000 units	1.2 mL	
			≥ 20 kg	1.2 million units	2.3 mL	
Offer CMI: May cause diarrhoea, nausea and pain at injection site						
Note: Ventrogluteal , p. 564 or vastus lateralis sites preferred. Do not give in deltoid. See Managing injection pain , p. 563						
Contraindication: Severe or immediate allergic reaction to a penicillin. Be aware of cross-reactivity between penicillins, cephalosporins and carbapenems						
Management of associated emergency: Consult MO/NP. See Anaphylaxis , p. 82						
3.5						

S4	Flucloxacillin			Extended authority ATSIHP/IHW/IPAP/RIPRN	
ATSIHP, IHW, IPAP and RN must consult MO/NP					
RIPRN may proceed					
Form	Strength	Route	Dose		Duration
Capsule	250 mg 500 mg	Oral	Adult 500 mg qid		7 days Stop earlier if infection has resolved
			Child 12.5 mg/kg (max. 500 mg) qid		
Offer CMI: Take on an empty stomach ½ hour before or 2 hours after food. May cause diarrhoea, nausea or thrush					
Note: Can cause cholestatic hepatitis. If renal impairment seek MO/NP advice					
Contraindication: History of cholestatic hepatitis with dicloxacillin or flucloxacillin. Severe or immediate allergic reaction to a penicillin. Be aware of cross-reactivity between penicillins, cephalosporins and carbapenems					
Management of associated emergency: Consult MO/NP. See Anaphylaxis , p. 82					
3.6					

S4	Cefalexin			Extended authority ATSIHP/IHW/IPAP/RIPRN	
ATSIHP, IHW, IPAP and RN must consult MO/NP					
RIPRN may proceed					
Form	Strength	Route	Dose		Duration
Capsule	250 mg	Oral	Adult 1 g bd		7 days Stop earlier if infection has resolved
	500 mg		Child 25 mg/kg (max. 1 g) bd		
Oral liquid	250 mg/5 mL				
Offer CMI: May cause rash, diarrhoea, nausea, vomiting, dizziness, headache or thrush					
Note: If renal impairment seek MO/NP advice					
Contraindication: Severe or immediate allergic reaction to a cephalosporin or a penicillin. Be aware of cross-reactivity between penicillins, cephalosporins and carbapenems					
Management of associated emergency: Consult MO/NP. See Anaphylaxis , p. 82					
3.7					

S4	Mupirocin			Extended authority ATSIHP/IHW/IPAP/RIPRN
ATSIHP, IHW, IPAP and RN must consult MO/NP				
RIPRN may proceed				
Form	Strength	Route	Dose	Duration
Ointment	2%	Topical	Apply to crusted areas tds	5 days
Offer CMI: Avoid contact with eyes and mouth. May cause itching, burning, redness, stinging, dryness, pain and swelling				
Management of associated emergency: Consult MO/NP. See Anaphylaxis, p. 82				3,8

5. Follow up

- If treated for widespread impetigo, advise to be reviewed daily initially
- If recurrent impetigo:^{3,9}
 - emphasise hygiene measures. May be reinfection from a close contact
 - once current infection healed, refer to next MO/NP clinic, who may consider decolonisation of Staph (if confirmed via nasal ± perineal swab) of patient ± household contacts
- If not responding to antibiotics:³
 - modify treatment based on results of MCS - discuss with MO/NP

6. Referral/consultation

- Consult MO/NP as above

HMP Boils - adult/child

Carbuncles, folliculitis

Background

- A boil (furuncle) is an infection of a hair follicle usually caused from Staph occasionally in combination with Group A Strep¹

1. May present with²

- **Boil:**
 - starts as firm, tender, red, swollen, lump
 - may be much larger than it appears on the surface
 - soon becomes painful + fluctuant (wave-like/boggy when palpated)
 - ± pustule on top ± oozing pus
- **Carbuncles** - boil with multiple heads¹
- **Note:** boils + carbuncles seldom cause systemic symptoms (eg fever, malaise), but may do, especially if associated with surrounding [Cellulitis, p. 306](#)
- **Folliculitis** - small boils/pustules that occur around hair follicles

2. Immediate management Not applicable

3. Clinical assessment^{1,2}

- Get history, including:
 - previous or recurrent boils - when, treatment
 - immunocompromised, diabetes
 - history of acute rheumatic fever (ARF) or valve replacement
- Examine boil(s) and surrounding skin. See [Skin assessment - adult, p. 21](#) or [Skin assessment - child, p. 485](#)
- Check lymph nodes
- Do vital signs + BGL in adults

4. Management^{1,2}

- Offer analgesia eg paracetamol. See [Acute pain, p. 32](#)
- Consult MO/NP if patient is/has:
 - a child
 - systemically unwell eg fever, malaise
 - carbuncles OR very large boil OR boil on face, hands, feet, perianal region or breast
 - immunocompromised
 - history of ARF or valve replacement - to discuss antibiotics (lower threshold to give)
- **Folliculitis:**
 - advise to use warm compresses - usually self-limiting
 - manage more severe cases as per boils below
- **Small boil or not yet fluctuant, advise:²**
 - apply moist heat to promote localisation + drainage
 - **do not squeeze** - this can force bacteria into the bloodstream causing sepsis or severe illness
 - check in 1–2 days to see if pus is draining. If not, may need incision and drainage (I&D)
 - wash hands after touching boil to prevent spreading infection

- **Larger fluctuant boil:**^{1,3}
 - requires incision and drainage + take swab for MCS
- **If boil > 5 cm OR if surrounding cellulitis:**^{1,4}
 - give oral antibiotics as per flowchart below (in addition to I&D + swab for MCS)

Antibiotics for boil > 5 cm OR if surrounding cellulitis^{1,4}

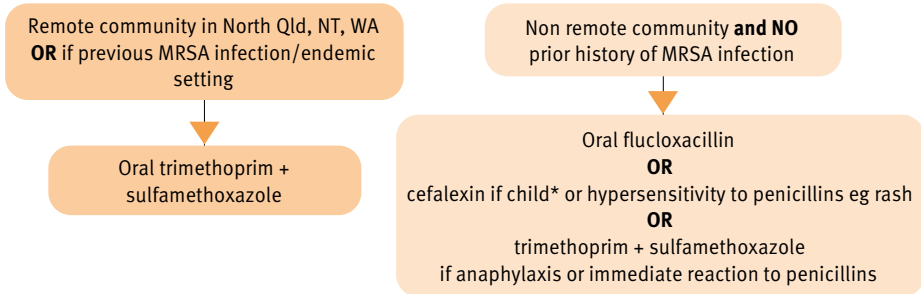

*If unable to swallow capsules, as cefalexin liquid tastes better than flucloxacillin liquid

- **In all cases, advise to:**⁵
 - wash hands regularly with soap or alcohol based hand sanitiser
 - not share towels/other personal hygiene items
 - have regular showers/bathing
 - cover open wounds
- **If recurring boils:**⁵
 - emphasise hygiene measures as above. May be reinfection from close contact
 - encourage to stop smoking + improve diabetes control as relevant
 - once current infection healed, refer to next MO/NP clinic, who may consider:
 - decolonisation of Staph (confirm via nasal ± perineal swab) of patient ± household contacts

Incision and drainage (I&D) of boil⁶

- Wear protective eyewear/PPE, as pus may squirt out
- Instil local anaesthetic (may not be needed if boil is superficial and 'pointing'):
 - approach the boil from the side + slowly infiltrate the skin above the boil with lidocaine (lignocaine) 1%. Do not inject into the boil
 - local anaesthetic may not be fully absorbed due to local inflammation. May need methoxyflurane/Entonox® instead (do not keep instilling local)
- Incise over area of greatest fluctuance with No. 11 or 15 scalpel blade:
 - make a single cut long enough to drain the pus
- Drain - carefully separate the skin using a blunt instrument eg forceps, to drain the pus:
 - **do not squeeze**
 - in larger boils, use finger/forceps to break down membranes inside boil
 - irrigate cavity with sodium chloride 0.9% until clear drainage
- If boil > 5 cm in size, or cavity looks like it may close, consider loosely placing a nonadhesive wick for about 12–24 hours. Do not tightly pack (to avoid skin necrosis)
- Cover with a dry dressing. Advise patient to change as needed

S ₄	Lidocaine (lignocaine)			Extended authority ATSIHP/IHW/RIPRN
ATSIHP, IHW and RN must consult MO/NP				
RIPRN may proceed				
Form	Strength	Route	Dose	Duration
Injection	1% 50 mg/5 mL	Subcut	Up to 3 mg/kg (max. 200 mg)	stat
Offer CMI: It will hurt as it goes in. Report any drowsiness, dizziness, blurred vision, vomiting or tremors				
Note: Use the lowest dose that results in effective anaesthesia				
Management of associated emergency: Ensure resuscitation equipment readily available. Consult MO/NP. See Anaphylaxis, p. 82				

S ₄	Trimethoprim + sulfamethoxazole			Extended authority ATSIHP/IHW/IPAP/RIPRN
ATSIHP, IHW, IPAP and RN must consult MO/NP				
RIPRN may proceed				
Form	Strength	Route	Dose	Duration
Tablet	80 + 400 mg 160 + 800 mg	Oral	Adult 160 + 800 mg bd Child ≥ 1 month 4 mg/kg (max. 160 mg) bd <i>Dose as per trimethoprim component</i>	5 days
Oral liquid	40 + 200 mg/5 mL			
Offer CMI: Take with food to reduce stomach upset. May cause fever, nausea, vomiting, diarrhoea, itch, rash or sore mouth. Avoid sun exposure. Report straight away if sore throat, fever, rash, cough, breathing difficulties, joint pain, dark urine or pale stools				
Note: If renal impairment, taking ACE inhibitor or potassium, HIV or SLE seek MO/NP advice				
Pregnancy: Do not use in the 1st trimester or in late pregnancy				
Contraindication: Severe or immediate allergic reaction to sulfonamides, megaloblastic anaemia, severe hepatic impairment, elderly				
Management of associated emergency: Consult MO/NP. See Anaphylaxis, p. 82				

S ₄	Flucloxacillin			Extended authority ATSIHP/IHW/IPAP/RIPRN
ATSIHP, IHW, IPAP and RN must consult MO/NP				
RIPRN may proceed				
Form	Strength	Route	Dose	Duration
Capsule	250 mg 500 mg	Oral	Adult 500 mg qid Child 12.5 mg/kg (max. 500 mg) qid	5 days
Offer CMI: Take on an empty stomach ½ hour before or 2 hours after food. May cause diarrhoea, nausea or thrush				
Note: Can cause cholestatic hepatitis. If renal impairment seek MO/NP advice				
Contraindication: History of cholestatic hepatitis with dicloxacillin or flucloxacillin. Severe or immediate allergic reaction to a penicillin. Be aware of cross-reactivity between penicillins, cephalosporins and carbapenems				
Management of associated emergency: Consult MO/NP. See Anaphylaxis, p. 82				

S4	Cefalexin		Extended authority ATSIHP/IHW/IPAP/RIPRN	
ATSIHP, IHW, IPAP and RN must consult MO/NP				
RIPRN may proceed				
Form	Strength	Route	Dose	Duration
Capsule	250 mg 500 mg	Oral	Adult and child \geq 12 years 1 g bd	5 days
Oral liquid	250 mg/5 mL		Child $<$ 12 years 25 mg/kg (max. 1 g) bd	
Offer CMI: May cause rash, diarrhoea, nausea, vomiting, dizziness, headache or thrush				
Note: If renal impairment seek MO/NP advice				
Contraindication: Severe or immediate allergic reaction to a cephalosporin or a penicillin. Be aware of cross-reactivity between penicillins, cephalosporins and carbapenems				
Management of associated emergency: Consult MO/NP. See Anaphylaxis, p. 82				1,10

5. Follow up

- If I&D, advise to be reviewed daily initially to assess and change dressings
- If infection does not improve within 72 hours of starting antibiotics (if given):¹
 - modify treatment based on results of MCS - discuss with MO/NP

6. Referral/consultation

- Consult MO/NP as above

HMP Cellulitis - adult/child

Background^{1,2}

- Acute serious spreading skin infection, often related to a recent break in the skin

1. May present with^{1,2}

- Spreading area of red, tender, skin ±
 - malaise, fever, chills
 - tender/enlarged lymph nodes
 - red streaks/tracking from the infected area towards armpit or groin
- Can rapidly intensify

2. Immediate management^{1,2}

- Do vital signs
- Screen for [Sepsis, p. 64](#). If suspected continue to manage as per **Sepsis**
- If redness is around the eye - medical emergency. See [Orbital/periorbital cellulitis, p. 288](#)

3. Clinical assessment^{1,2}

- Get history, including:
 - recent skin trauma (2–3 days ago) - when, what, where eg:
 - cut, abrasion, scabies, insect bite
 - surgery, IV drug use/skin popping
 - related to water immersion eg sea, fresh, brackish, mud, coral cut, marine bite¹
 - other symptoms - onset, severity, duration
 - diabetes, immunocompromised
- Do physical examination, including:
 - BGL
 - [Skin assessment - adult, p. 21](#) or [Skin assessment - child, p. 485](#)
 - palpate lymph nodes¹
 - assess for associated abscess/[Boils, p. 302](#), although may be difficult if skin is hardened¹
- Consider ‘mimics’ of cellulitis as differential diagnoses eg³ [DVT, p. 124](#), [Gout, p. 326](#), septic arthritis

4. Management^{1,2}

- Offer analgesia. See [Acute pain, p. 32](#)
- **Consult MO/NP promptly** if patient is/has:
 - a child
 - systemically unwell eg malaise, fever, chills
 - redness that is extensive **OR** on hand or face **OR** over a joint
 - abscess suspected
 - severe pain/tenderness, or necrosis
 - diabetes, immunocompromised

If severe cellulitis/patient IS systemically unwell

- Insert IVC x 2
- MO/NP may order:
 - blood cultures

- IV antibiotics
- evacuation/hospitalisation

If mild cellulitis/patient is NOT systemically unwell

- If water immersion related, give antibiotics as per [Water related wounds, p. 170](#)
- Otherwise, give oral antibiotics as per flowchart below
- Dress any wound/site of injury:
 - if possible photograph to monitor response to treatment
 - **note:** resolving cellulitis may continue to spread ≥ 24 hours after antibiotics started
- If related to surgery/sutured wound, sutures may need removing.⁶ Consult MO/NP
- Advise to rest and elevate the affected area for as long as it is swollen, hot and red

Antibiotics for mild cellulitis^{1,7}

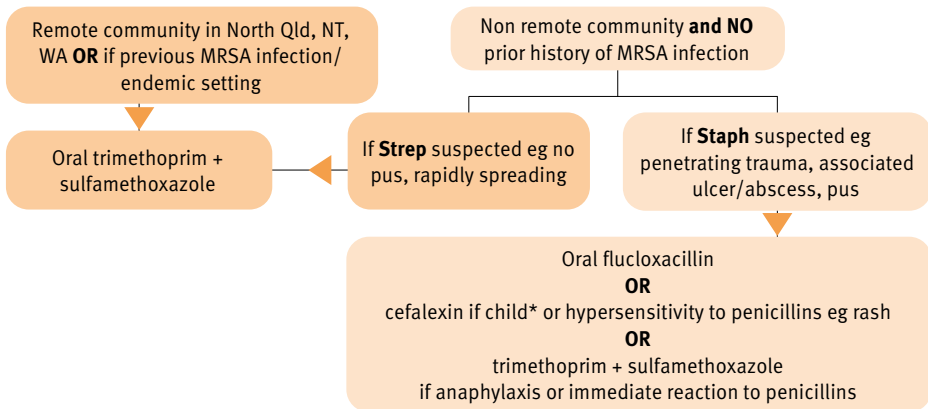

*If unable to swallow capsules, as cefalexin liquid tastes better than flucloxacillin liquid

S4	Trimethoprim + sulfamethoxazole		Extended authority ATSIHP/IHW/IPAP/RIPRN	
ATSIHP, IHW, IPAP and RN must consult MO/NP RIPRN may proceed				
Form	Strength	Route	Dose	Duration
Tablet	80 + 400 mg 160 + 800 mg	Oral	Adult 160 + 800 mg bd Child ≥ 1 month 4 mg/kg (max. 160 mg) bd <i>Dose as per trimethoprim component</i>	5 days
Oral liquid	40 + 200 mg/ 5 mL			
Offer CMI: Take with food to reduce stomach upset. May cause fever, nausea, vomiting, diarrhoea, itch, rash or sore mouth. Avoid sun exposure. Report straight away if sore throat, fever, rash, cough, breathing difficulties, joint pain, dark urine or pale stools				
Note: If renal impairment, taking ACE inhibitor or potassium, HIV or SLE seek MO/NP advice				
Pregnancy: Do not use in the 1st trimester or in late pregnancy				
Contraindication: Severe or immediate allergic reaction to sulfonamides, megaloblastic anaemia, severe hepatic impairment, elderly				
Management of associated emergency: Consult MO/NP. See Anaphylaxis, p. 82				1,4,6

S4	Flucloxacillin			Extended authority ATSIHP/IHW/IPAP/RIPRN
ATSIHP, IHW, IPAP and RN must consult MO/NP				
RIPRN may proceed				
Form	Strength	Route	Dose	Duration
Capsule	250 mg 500 mg	Oral	Adult 500 mg qid Child 12.5 mg/kg (max. 500 mg) qid	5 days
Offer CMI: Take on an empty stomach ½ hour before or 2 hours after food. May cause diarrhoea, nausea or thrush				
Note: Can cause cholestatic hepatitis. If renal impairment seek MO/NP advice				
Contraindication: History of cholestatic hepatitis with dicloxacillin or flucloxacillin. Severe or immediate allergic reaction to a penicillin. Be aware of cross-reactivity between penicillins, cephalosporins and carbapenems				
Management of associated emergency: Consult MO/NP. See Anaphylaxis, p. 82				1,5

S4	Cefalexin			Extended authority ATSIHP/IHW/IPAP/RIPRN
ATSIHP, IHW, IPAP and RN must consult MO/NP				
RIPRN may proceed				
Form	Strength	Route	Dose	Duration
Capsule	250 mg 500 mg	Oral	Adult 500 mg qid Child	5 days
Oral liquid	250 mg/5 mL		12.5 mg/kg (max. 500 mg) qid	
Offer CMI: May cause rash, diarrhoea, nausea, vomiting, dizziness, headache or thrush				
Note: If renal impairment seek MO/NP advice				
Contraindication: Severe or immediate allergic reaction to a cephalosporin or a penicillin. Be aware of cross-reactivity between penicillins, cephalosporins and carbapenems				
Management of associated emergency: Consult MO/NP. See Anaphylaxis, p. 82				1,8

5. Follow up¹

- If not evacuated, advise to be reviewed daily initially for wound care:
 - monitor redness and any other skin changes eg blistering, necrosis
 - advise to moisturise the area as it becomes less sore to prevent cracking and skin breakdown
- Consult MO/NP if not improving, pain worsening, or unusual skin changes noted:
 - ↑ pain may mean abscess, poor response to treatment, or more serious infection eg necrotising fasciitis

6. Referral/consultation

- Consult MO/NP as above

HMP Shingles - adult/child

Background^{1,2}

- Shingles is reactivation of the varicella-zoster virus (VZV) in a person (usually > 50 years) who has had chicken pox. It causes a painful blistering rash
- Usually self-limiting but can result in persistent pain for > 3 months after rash healed or other complications eg blindness, pneumonia, hearing problems, swelling of the brain, death

1. May present with^{1,3}

- Rash that develops into small blisters within 24–48 hours:
 - on 1 side of the body along a nerve pathway
 - crusts over within 5 days
- 48–72 hours prior to rash appearing, may have:
 - headache, photophobia, malaise
 - itching, tingling or severe pain in the area

2. Immediate management Not applicable

3. Clinical assessment^{1,3}

- Get history, including:
 - history of rash
 - other signs and symptoms
 - immunocompromised
 - prior chicken pox
- Do vital signs
- Examine skin. See [Skin assessment - adult, p. 21](#) or [Skin assessment - child, p. 485](#)
- Take swab of lesion for VZV PCR⁴

4. Management³

- **Consult MO/NP promptly** if:
 - child
 - rash on face or eye - will need evacuation/review by ophthalmologist:
 - MO/NP may consider early use of aciclovir eye ointment
 - immunocompromised
 - pregnant
- **For relief of pain:**⁵
 - offer paracetamol. See [Acute pain, p. 32](#)
 - advise ice packs and protective dressings may help
 - lidocaine (lignocaine) ointment or similar numbing ointment may be tried for a few days
 - if severe pain and above does not work, consult MO/NP who may order:
 - oral prednisolone, amitriptyline or oxycodone
- **If rash started < 72 hours ago**, give adult:
 - oral valaciclovir
 - advise this will reduce pain, duration of rash and complications
- If skin infection also present, treat as for [Impetigo, p. 298](#) or [Cellulitis, p. 306](#)
- Give advice on how to stop shingles from spreading to others

Shingles advice²

- Cover the rash (if possible):
 - if child, exclude from school if unable to cover, or until no new blisters in 24 hours⁶
- Avoid touching or scratching the rash
- Wash hands often to prevent the virus from spreading
- **Avoid contact with these people until the rash has developed crusts:**
 - pregnant women who have never had chickenpox or the chickenpox vaccine (although not harmful to your unborn baby if you have shingles)
 - premature or low birth weight babies
 - children who have not had chickenpox or the chickenpox vaccine
 - people with weakened immune systems eg:
 - chemotherapy
 - taking medicines that weaken their immune system
 - had a transplant
 - living with HIV
- You can still receive the zoster vaccine at the recommended age¹

S4	Valaciclovir			Extended authority ATSIHP/IHW/IPAP/RIPRN	
ATSIHP, IHW, IPAP and RN must consult MO/NP					
RIPRN may proceed					
Form	Strength	Route	Dose	Duration	
Tablet	500 mg	Oral	Adult 1 g tds	7 days	
Offer CMI: Drink plenty of fluids - at least 1.5 L/day. May cause dizziness or confusion					
Note: If renal impairment seek MO/NP advice					
Pregnancy: Aciclovir preferred. May be used from 36 weeks gestation					
Contraindication: Allergy to valaciclovir or aciclovir					
Management of associated emergency: Consult MO/NP. See Anaphylaxis, p. 82					3-7

5. Follow up

- Advise to see MO/NP at next clinic

6. Referral/consultation⁴

- Probable or confirmed shingles requires notification to your Public Health Unit ☉

HMP Tinea/ringworm - adult/child

Jock itch, athlete's foot, fungal infection of nail

1. May present with^{1,2}

Ringworm eg tinea corporis, tinea faciale	<ul style="list-style-type: none"> • 1 or more ring shaped red patches/plaques. Has central clearing as it expands • Border well-defined, slightly raised, sometimes scaly • Usually on trunk, face, arms or legs • Often itchy
Scalp ringworm Tinea capitis	<ul style="list-style-type: none"> • Itchy, scaly plaques or patches on scalp • Patches of hair loss; black dots where hair broken off • May be a hardened, boggy, pustular mass which looks like a boil • Most common in 3–7 year olds
Jock itch Tinea cruris	<ul style="list-style-type: none"> • Red itchy, scaly rash on upper thigh and groin; not usually on scrotum • Most common in adolescent and adult males • Risk factors - sweating in groin, occlusive clothing, immunocompromised
Athletes foot Tinea pedis	<ul style="list-style-type: none"> • Itching or burning ± odour of feet, especially between toes • Scaling, maceration or sloughing of skin • Often spreads to nails
Fungal infection of nail Onychomycosis	<ul style="list-style-type: none"> • Nail discolouration + thickening, separation of nail from nail bed

2. Immediate management Not applicable

3. Clinical assessment²

- Get history, including:
 - onset, duration, itchy/burn/tenderness
 - prior infections/treatment, animal contact
 - immunocompromised, diabetes
- Do vital signs
- Examine skin. See [Skin assessment - adult, p. 21](#) or [Skin assessment - child, p. 485](#)
- If jock itch - check feet as possible source of infection:
 - consider differential diagnosis of [Candidiasis \(skin\), p. 313](#) - note treatment is the same
- Look for signs of a secondary bacterial infection eg tender/red skin, weeping/glistening, crusts
- Consider other diagnoses (can be hard to tell the difference) eg eczema, dermatitis, psoriasis

4. Management^{1,2}

- If secondary bacterial skin infection, treat first. See [Impetigo, p. 298](#) or [Cellulitis, p. 306](#)
- Refer to next MO/NP clinic if:
 - widespread skin involvement
 - is on the nails, scalp, palms or soles
 - immunocompromised
 - recurrent infection or has not responded to topical treatment
 - MO/NP may order oral griseofulvin or terbinafine + fungal MCS (skin scraping from edge, nail clippings or plucked hair)

- Treat all other tinea with antifungal cream eg:¹
 - terbinafine (preferred) or miconazole
- Offer advice/preventative measures:²
 - keep area as dry as possible eg wear loose clothing, dry well between toes
 - avoid walking barefoot in public showers, put moist footwear in sun to dry
 - improve diabetes/weight control as relevant, avoid infected pets/farm animals
 - is spread by direct contact (via break in skin) with infected people, pets or contaminated objects eg combs, clothing, footwear, bedding or shared towels

S2	Terbinafine			Extended authority ATSIHP/IHW/IPAP
ATSIHP, IHW, IPAP and RIPRN may proceed				
RN may administer; for supply see RN supplying, p. 11				
Form	Strength	Route	Dose	Duration
Cream	1%	Topical	Apply a thin layer once or twice a day	1–2 weeks
Offer CMI: Clean and dry affected areas well before applying to the affected and surrounding skin. For treatment to be successful you have to use it regularly. Do not cover with a dressing. Complete the full course even if your skin looks better				
Management of associated emergency: Consult MO/NP. See Anaphylaxis, p. 82				1,4

S2	Miconazole			Extended authority ATSIHP/IHW/IPAP
ATSIHP, IHW, IPAP and RIPRN may proceed				
RN may administer; for supply see RN supplying, p. 11				
Form	Strength	Route	Dose	Duration
Cream	2%	Topical	Apply a thin layer bd	Continue using for 2 weeks after symptoms have gone
Offer CMI: Apply to the affected and surrounding skin. Pay particular attention to skin folds. For treatment to be successful you have to use it regularly				
Management of associated emergency: Consult MO/NP				5

5. Follow up¹

- Advise to be reviewed at next MO/NP clinic if no improvement after 2 weeks

6. Referral/consultation

- Consult MO/NP as above

HMP Candidiasis (skin) - adult/child

1. May present with^{1,2}

- Red itchy rash/patches ± small blisters and pustules
- Most common in warm/moist areas eg axillae, groin, under breasts, abdominal folds, nappy area

2. Immediate management Not applicable

3. Clinical assessment^{1,2}

- Get history, including:
 - onset, duration, prior infections/treatment, other symptoms
 - pre-disposing factors eg:
 - diabetes, immunocompromised
 - taking antibiotics or corticosteroids
 - obesity, immobility
- Do vital signs + BGL in adults
- Examine skin. See [Skin assessment - adult, p. 21](#) or [Skin assessment - child, p. 485](#)

4. Management^{1,2}

- Refer to next MO/NP clinic if widespread or immunocompromised:
 - may order oral fluconazole ± MCS
- Otherwise, treat with antifungal cream eg miconazole
- Advise:
 - keep skin as clean and dry as possible
 - improve diabetes/weight control as relevant

S2	Miconazole			Extended authority ATSIHP/IHW/IPAP
ATSIHP, IHW, IPAP, MID and RIPRN may proceed				
RN may administer; for supply see RN supplying, p. 11				
Form	Strength	Route	Dose	Duration
Cream	2%	Topical	Apply a thin layer bd	Continue using for 2 weeks after symptoms have gone
Offer CMI: Apply to the affected and surrounding skin. Pay particular attention to skin folds. For treatment to be successful you have to use it regularly				
Management of associated emergency: Consult MO/NP				1-3

5. Follow up¹

- Advise to be reviewed at next MO/NP clinic if no improvement after 2 weeks

6. Referral/consultation

- Consult MO/NP as above

HMP *Tinea versicolor* (pityriasis versicolor) - adult/child

1. May present with^{1,2}

- Flat patches of hyper/hypo-pigmented skin eg pink, tan, brown or red:
 - in dark skinned people can cause light patches of skin
 - ± fine scales
- Common on chest, back, neck, upper arms (not face)
- Common in adolescents and young adults in tropical climates/heavy sweating

2. Immediate management Not applicable

3. Clinical assessment²

- Get history
- Do vital signs
- Examine skin. See [Skin assessment - adult, p. 21](#) or [Skin assessment - child, p. 485](#)
- Consider other diagnoses eg [Tinea/ringworm, p. 311](#), secondary [Syphilis, p. 468](#), [Leprosy, p. 315](#)

4. Management¹⁻³

- Treat with an antifungal shampoo eg:
 - selenium sulfide shampoo (Selsun Gold®) - can buy from supermarket:
 - apply to wet skin, leave on for 10 minutes or overnight. Repeat for 7–10 days¹
 - ketoconazole shampoo
 - econazole foaming liquid
- Advise:
 - wash whole body with the antifungal shampoo, including the hair
 - caused by yeast infection, that is normally present on skin
 - treatment is only needed for cosmetic reasons
 - it may take several weeks or months for skin to return to its normal colour
 - recurrence is common and repeated treatment may be needed

S2	Ketoconazole shampoo			Extended authority ATSIHP/IHW/IPAP
ATSIHP, IHW, IPAP and RIPRN may proceed				
RN may administer; for supply see RN supplying, p. 11				
Form	Strength	Route	Dose	Duration
Shampoo	2%	Topical	Apply, leave for 5 minutes then wash off	Repeat for up to 5 days
Offer CMI: May cause burning, stinging, itch or redness. A single application may be effective				
Pregnancy: Avoid; safe in breastfeeding				
Management of associated emergency: Consult MO/NP				1,4

5. Follow up¹

- Advise to see MO/NP if persistent. Oral fluconazole may be required

6. Referral/consultation

- Consult MO/NP as above

Leprosy (Hansen's disease) - adult/child

Recommend¹

- Consider leprosy in patients with persistent undiagnosed skin lesions in Northern Australia

1. May present with^{1,2}

- Lighter (or reddish) patches of skin/ulcer with loss of sensation
- Thickened or enlarged peripheral nerve with loss of sensation ± weakness of the muscles supplied by that nerve

2. Immediate management Not applicable

3. Clinical assessment^{1,2}

- Get history, including:
 - onset, duration, location, loss of sensation of lesions
 - other signs or symptoms
- Do vital signs
- Examine lesions. See [Skin assessment - adult, p. 21](#) or [Skin assessment - child, p. 485](#)
 - use cotton wool to test for sensation on lesion(s) - roll the cotton wool to a point and touch the skin so the point bends (don't stroke the skin)²
 - palpate for thickened or enlarged nerves - feel wrist, elbow or behind knee, neck

4. Management^{1,2}

- If leprosy suspected, consult MO/NP who may consider:
 - leprosy PCR - biopsy of lesion (preferred) **OR** if an open lesion, swab. Seek advice from pathology
 - **Note:** *Guidelines for the control of leprosy in the Northern Territory 2018* provide instructions on taking pathology and detailed physical examination for leprosy <https://digitallibrary.health.nt.gov.au/prodjsmui/bitstream/10137/526/3/Control%20of%20Leprosy%20in%20the%20Northern%20Territory%20Guidelines.pdf>
- If leprosy suspected/confirmed, MO/NP will treat in consultation with specialist. Requires long-term medication and follow up

5. Follow up²

- Monitor medicine regime and provide support to patient to complete course as needed

6. Referral/consultation³

- Confirmed leprosy requires notification to your Public Health Unit ①

HMP Scabies - adult/child

Recommend¹

- Treat scabies promptly. Secondary skin infections from scratching can cause [APSGN, p. 511](#) and [ARF, p. 515](#)

Background¹

- Caused by infestation with scabies mite. Spread by close physical contact
- The mite causing dog scabies (mange) does not affect humans¹
- See *National healthy skin guideline* <https://infectiousdiseases.telethonkids.org.au/resources/skin-guidelines/> for further information + photos of scabies and infected scabies/impetigo

1. May present with¹

- **Scabies:**
 - small bumps/papules, blisters ± tiny burrows
 - very itchy, worse at night
 - **commonly found** - in webbing of fingers/toes, elbows, wrists
 - **other common sites** - armpit, belt line, abdomen, breasts, buttocks, thighs, genitals
 - **infants** - pustules on palms and soles of feet (or widespread + head, neck)
- **Crusted (Norwegian) scabies** (thousands of mites which shed with the skin):
 - scaling and crusting on the skin; often not itchy
 - creamy colour
 - few patches or can cover whole body
 - usual on buttocks, elbows and arms; palms and soles of feet may be cracked
 - may look similar to [Tinea/ringworm, p. 311](#), psoriasis, eczema or dermatitis
 - **highly infectious**

2. Immediate management Not applicable

3. Clinical assessment¹

- Get history, including:
 - immunocompromised
- Do vital signs
- Examine skin:
 - see [Skin assessment - adult, p. 21](#) or [Skin assessment - child, p. 485](#)
 - look for signs of infected scabies (impetigo):
 - pus or honey coloured filled bumps/blisters, weeping/glistening/redness/crusts
- If crusted (Norwegian) scabies suspected:
 - take skin scraping for microscopy to confirm presence of mites
 - ask about living arrangements - is very infectious

4. Management¹

Scabies:

- Treat with permethrin (Lyclear®) cream:
 - can be applied to scratched/broken skin. Only avoid if obvious irritation occurs
 - give **Scabies advice**
- If infected scabies, treat at same time. See [Impetigo, p. 298](#)

Scabies advice^{1,2}

Applying Lyclear® - apply first treatment in clinic if needed

- Apply after shower in evening to **whole body** including:
 - face + scalp (not lips and eyes)
 - between fingers, toes, soles of feet, under nails (use nail brush), behind ears, genitalia
 - in all body creases eg elbows, knees etc
- Leave on overnight. Or if prior treatment failure (and > 6 months old), leave on for 24 hours
- Reapply if washing hands. Put on child's hands again before bed
- **If infant < 6 months** - cover hands to avoid child sucking the medication. Leave on for 8 hours
- Repeat in 7 days

Other advice¹⁻³

- Treat household/close contacts at the same time, even if no symptoms
- Wash clothes/bedding morning after treatment + dry in the sun (may help)
- Keep home from school/childcare until the day after 1st treatment⁴
- Itch can persist 2–4 weeks after treatment. If problematic, MO/NP may order a corticosteroid cream

Crusted (Norwegian) scabies¹

- If severe, patient may need to be hospitalised
- Consult MO/NP, who may seek infectious disease specialist advice + order:
 - ivermectin
 - **PLUS** 2nd daily benzyl benzoate lotion (can use Lyclear® if not available)
 - **PLUS** Calmurid® cream (10% urea, 5% lactic acid in sorbolene cream) - to reduce scaling/soften skin crusts:
 - use on days when benzyl benzoate not applied
 - apply after shower to crusted/thickened skin
 - the next day, soak/scrub the crusts with a sponge, then apply benzyl benzoate
- Prompt treatment and community control efforts are essential:
 - can cause scabies outbreaks - get advice from Public Health Unit

Crusted (Norwegian) scabies advice¹

- Wash clothes/sheets/towels in hot water **daily** and dry in the sun **OR** put in sealed plastic bag for 8 days to kill the mites
- Vacuum the floors and furniture in the house + the floors and seats in cars, to remove mites + skin flakes
- Treat household/close contacts for scabies + regularly check for scabies

Unscheduled		Permethrin (Lyclear®)		
ATSIHP, IHW, IPAP, MID, RIPRN and RN may proceed				
Form	Strength	Route	Dose	Duration
Cream	5% 30 g tube	Topical	> 12 years to adult up to 1 tube 5–12 years up to 1/2 tube 1–5 years up to 1/4 tube < 12 months up to 1/8 tube	Apply on day 1 Repeat in 7 days
Offer CMI: May temporarily increase itch, redness and swelling				
Management of associated emergency: Consult MO/NP. See Anaphylaxis, p. 82				

5

Unscheduled		Benzyl benzoate		
ATSIHP, IHW, IPAP, MID, RIPRN and RN may proceed				
Form	Strength	Route	Dose	Duration
Lotion	25%	Topical	Adult - apply undiluted 2–12 years - dilute with equal part water 6 months–2 years - dilute with 3 parts water	Crusted scabies Apply every 2nd day for 1 week, then 2–3 times a week until cured
Offer CMI: May cause stinging or burning sensation when first applied. Do not use on acutely inflamed, raw or weeping skin. May be irritating to face and genitals				
Pregnancy: Permethrin preferred				
Management of associated emergency: Consult MO/NP. See Anaphylaxis, p. 82 1,6				

S4	Ivermectin			Extended authority ATSIHP/IHW/IPAP
ATSIHP, IHW, IPAP, RIPRN and RN must consult MO/NP				
Form	Strength	Route	Dose	Duration
Tablet	3 mg	Oral	Adult and child > 15 kg 200 microg/kg (rounded up to the nearest 3 mg)	Scabies if topical treatment fails or is contraindicated Once. Repeat in 1 week Crusted scabies Once on days 1, 2 and 8
Offer CMI: Take with fatty food. May cause headache, fatigue, dizziness, abdominal pain, vomiting or diarrhoea. Resistance can occur after repeated use				
Pregnancy: Do not use. Safe in breastfeeding ⁵				
Management of associated emergency: Consult MO/NP. See Anaphylaxis, p. 82 1,7				

5. Follow up

Scabies

- If itch still present > 4 weeks after treatment:²
 - check applied Lyclear® correctly, contacts were treated and household measures followed
 - consider trying benzyl benzoate lotion instead³
 - **OR** consult MO/NP who may consider oral ivermectin/specialist referral/other diagnosis¹⁻³

Norwegian/crusted scabies

- If not hospitalised, provide ongoing treatment support until cured (daily initially)¹

6. Referral/consultation

- If crusted (Norwegian) scabies consult Public Health Unit. **Note:** is notifiable in NT ①

Head lice/nits - adult/child

1. May present with¹

- Itchy scalp and neck
- White eggs or lice in hair
- Sores on head

2. Immediate management Not applicable

3. Clinical assessment¹

- Look in hair/scalp for:
 - eggs (nits) attached to the base of hairs
 - moving louse - use **wet combing** to detect
 - infected sores from scratching:
 - if sores, look for signs of [APSGN, p. 511](#) and [ARF, p. 515](#)

Wet combing¹

- Apply a generous amount of hair conditioner to wet hair. Conditioner stuns the lice for 20 minutes
- De-tangle hair, divide into sections
- Comb sections with a fine-toothed comb eg nit comb
- Wipe conditioner off the comb onto paper towel or tissue. Look for lice and nits

4. Management¹

- If infected sores treat at the same time. See [Impetigo, p. 298](#)
- Advise parent/carer to treat with wet combing method or head lice treatment (insecticide) below
- **Wet combing method:**
 - repeat wet combing (as above) daily until no lice are found
 - only about 40% success rate
- **Head lice treatment:**
 - use a topical insecticide eg:
 - malathion (KP24®), or
 - pyrethrins + piperonyl butoxide eg Banlice Mousse® or Pyrenel Foam®

Head lice treatment (insecticide)

- Apply as per instructions on container
- Repeat treatment in 7 days
- Use wet combing the day after each treatment to check for live lice:
 - if live lice are found, despite correctly applied treatment, the lice may be resistant
 - try another topical insecticide OR use wet combing method
- In between treatments, use the wet combing method twice. Remove eggs from the scalp with the fine-toothed comb or pull off with fingernails
- **Advise parent/carer:**
 - repeat wet combing weekly for several weeks after cure to detect recurrence
 - wash pillow cases and comb/brush in hot water
 - check household contact using wet combing method and treat if needed
 - advise child's school of the infestation (child can return to school after initial treatment)

5. Follow up

- Advise to return if lice continue regardless of treatment

6. Referral/consultation

- Consult MO/NP if persistent

HMP Nappy rash - adult/child

Background¹

- Usually caused by contact dermatitis from exposure to excess moisture and prolonged contact with faeces and urine

1. May present with¹

- Rash in nappy area:
 - mild - scattered pinpoint red papules
 - moderate - mild redness, some maceration and chafing
 - severe - extensive redness, maceration, superficial erosions + discomfort/pain

2. Immediate management Not applicable

3. Clinical assessment

- Get history, including:
 - duration of rash
 - recent diarrhoea/frequent stools
 - nappy changing - frequency, type of nappy used
 - use of fragrant powders, creams, soaps/detergents
- Examine skin. See [Skin assessment - adult, p. 21](#) or [Skin assessment - child, p. 485](#)

4. Management^{1,2}

- If severe, consider consulting with child health nurse, midwife or MO/NP
- Discuss nappy change practices to help treat and prevent nappy rash eg:²
 - use disposable nappies if possible:
 - if unable/prefers not to, advise to change nappies 2 hourly, avoid plastic over-pants and liners
 - frequent nappy changes
 - periods of nappy free time
 - apply a barrier cream, ointment or paste at every nappy change:
 - eg zinc and castor oil, zinc oxide
 - use fragrant free wipes or plain water/soap substitute. Do not wipe excessively
- Consider non-accidental injury or neglect where presentation is inconsistent with history or is unexpected eg scaled skin, bruising, object shaped lesions in nappy area, poor hygiene, developmental delay.² See [Child protection, p. 551](#)
- Consider secondary infection if there are:²
 - shiny red patches with satellite lesions in nappy area, groin ± oral thrush ± rash persisting for > 3 days. Consider treating for [Candidiasis \(skin\), p. 313](#)
 - pustules, erosions, ulcers or weeping - suspect bacterial infection:¹
 - take swab for MCS to confirm
 - treat localised and widespread infections with oral antibiotics as per [Impetigo, p. 298](#)

5. Follow up

- If moderate/severe, advise to be reviewed daily initially. Otherwise review if concerned

6. Referral/consultation

- Consult child health nurse/midwife/MO/NP as above

Diabetic foot infection

HMP Diabetic foot infection ± osteomyelitis - adult

Recommend¹

- Diabetic foot infection should always be considered serious. It is often worse than it appears
- Be alert for Charcot foot - a serious + potentially lower limb-threatening complication of diabetes

1. May present with¹

- For an ulcer to be considered infected, ≥ 2 of the following need to be present:
 - local swelling or localised hardening of soft tissue
 - redness extending > 0.5 cm in any direction from the wound
 - local tenderness or pain
 - local warmth
 - purulent discharge
- Charcot foot - localised unilateral swelling ± pain, erythema, deformity, warmth

2. Immediate management

- Do vital signs
- Screen for [Sepsis, p. 64](#)

3. Clinical assessment

- Consider other causes of inflammation eg trauma, gout, thrombosis¹
- Get history, including:¹
 - peripheral neuropathy, peripheral arterial disease, foot deformity (high risk for amputation)
 - onset of ulcer
 - past episodes, when, treatment
 - fevers, rigors or other systemic symptoms
 - current medications, adherence
 - recently taken antibiotics
 - smoking
 - recent trauma or surgery to foot/ankle
- Do physical examination, including:
 - BGL
 - palpate pedal pulses - bounding pulses may indicate Charcot foot
 - test for protective sensation with monofilament if available
 - measure redness from wound margin - if ≤ 2 cm + involves only the skin + subcutaneous tissue with no systemic features - indicates mild infection¹

- note size, location + depth of ulcer:¹
 - probe using a sterile probe, with slow gentle force. Assess all extents of the ulcer. If bone can be probed - indicates high risk of osteomyelitis, consider x-ray
- Take wound swab for MCS, see [How to take a wound swab, p. 324](#)¹
 - do not take MCS from non-infected ulcers

4. Management

- Consult MO/NP in all cases, who may advise:^{1,2}
 - antibiotics ± evacuation/hospitalisation depending on severity
 - **note:** if osteomyelitis MO/NP may order IV antibiotics
 - ± bloods - HbA_{1c}, FBC, CRP, UE + GFR, glucose
 - x-ray if available to rule out osteomyelitis
 - if vascular status not adequate or osteomyelitis, referral to vascular or orthopaedic surgeon
- Offer analgesia. See [Acute pain, p. 32](#)
- If mild infection treated in community, MO/NP may order antibiotics eg:¹
 - trimethoprim + sulfamethoxazole - MRSA/remote area in North Qld, NT, WA
 - flucloxacillin - other areas/low risk of MRSA
- If not evacuated, refer/manage in collaboration with closest high risk foot clinic, for advice on:¹
 - interventions - offloading pressure devices are critical eg soft boots, removable cast²
 - wound care/dressing regime eg initial antimicrobial dressing²
 - management of hyperglycaemia, vitamin C + thiamine supplements if indicated
- Advise patient to rest, avoid weight-bearing activities + encourage smoking cessation if appropriate¹

S4	Trimethoprim + sulfamethoxazole			Extended authority ATSIHP/IHW/IPAP
ATSIHP, IHW, IPAP, RIPRN and RN must consult MO/NP				
Form	Strength	Route	Dose	Duration
Tablet	80 + 400 mg 160 + 800 mg	Oral	160 + 800 mg bd	As per MO/NP Typically 1–2 weeks is sufficient
Offer CMI: Take with food to reduce stomach upset. May cause fever, nausea, vomiting, diarrhoea, itch, rash or sore mouth. Avoid sun exposure. Report straight away if sore throat, fever, rash, cough, breathing difficulties, joint pain, dark urine or pale stools				
Note: If renal impairment, taking ACE inhibitor or potassium, HIV or SLE seek MO/NP advice				
Pregnancy: Do not use in the 1st trimester or in late pregnancy				
Contraindication: Severe or immediate allergic reaction to sulfonamides, megaloblastic anaemia, severe hepatic impairment, elderly				
Management of associated emergency: Consult MO/NP. See Anaphylaxis, p. 82				1:3

5. Follow up

- If not evacuated:
 - review daily initially as patient can deteriorate rapidly
 - check MCS result + contact MO/NP if need to modify antibiotics based on results
 - continue antibiotics until infection is resolved but not necessarily until the ulcer is healed¹
- As per MO/NP/diabetes team/high risk foot team

6. Referral/consultation

- Refer to diabetes educator, podiatrist, high risk foot clinic if available

Chronic wounds

HMP Chronic wounds - adult

1. May present with

- Chronic wound/ulcer ± infection

2. Immediate management Not applicable

3. Clinical assessment

- **Ask about wound:**¹
 - onset eg spontaneous, traumatic, caused by foreign body
 - duration
 - what concerns do they have about their wound eg pain, restricted mobility, swelling, exudate leakage, odour
 - treatments already used + response
 - any recent radiotherapy or surgery near wound
- **Get medical/surgical history,** including:¹
 - any risk factors eg diabetes, smoking, alcohol intake, heart disease, blood disorders, rheumatoid arthritis, disorders affecting nutrition
 - **note:** if diabetic + suspected infection, go to [Diabetic foot infection, p. 321](#)
 - current medications + allergies
 - previous ulcers, when, treatment, any imaging/investigations
- Do vital signs + BGL
- **Do physical examination** + look for signs of:¹
 - vascular disease eg oedema, ↓ or absent lower limb pulses, pale, cold or tender foot
 - anaemia eg pallor
 - systemic infection eg fever, ↑ HR, swollen lymph nodes
 - dehydration, signs of malnutrition
- If dressing in situ - remove gently. If adhered soak off with warm sodium chloride 0.9%

Examine wound¹

- **Tissue** - at ulcer base eg necrosis, slough, hypergranulation:
 - if visible deeper tissue eg bone, tendon or muscle - measure length, width + depth
 - probe using a sterile probe:
 - foot ulcers - with slow gentle force, assess all extents of the ulcer. If bone can be probed - indicates high risk of osteomyelitis,¹ see [Diabetic foot infection, p. 321](#)
 - sacrum, buttock or hip area - check for sinus tracts, bone, cavity
- **Infection/inflammation** - check for delayed healing, ↑ pain, exudate, odour + spreading cellulitis:
 - if signs of infection take wound swab for MCS before starting antibiotics¹
 - **note:** do not take MCS from noninfected ulcers/wounds
- **Moisture balance** - any exudate, amount + type eg serous, purulent, scant
- **Edge + skin within 4 cm of wound edge** eg flat, sloping, indistinct, punched out, not attached

How to take a wound swab²

- Cleanse + debride the wound with warm sterile sodium chloride 0.9%
- Moisten swab tip with sterile sodium chloride 0.9% + advise patient it may cause discomfort
- Firmly press swab tip into cleanest area - rotate for 5 seconds with sufficient pressure so that tissue fluid is produced. Avoid slough or necrotic tissue
- On pathology form - note wound location, duration, any significant comorbidities, clinical indication eg signs/symptoms + current or recent antibiotic use

4. Management³

- Offer analgesia. See [Acute pain](#), p. 32
- Consult MO/NP for ongoing management if:
 - non-healing leg ulcer
 - suspected osteomyelitis or signs of infection
 - wound on hands or face, with extensive necrotic tissue or exposed bone
- MO/NP may seek specialist advice + order:
 - antibiotics, bloods
 - evacuation/hospitalisation depending on severity/cause

Wound care + dressing⁴

- Cleanse + debride as needed with warm sterile sodium chloride 0.9%
- Use the table below to guide dressing options for the amount of exudate

Dressings for optimal moisture balance				
Dry Wounds	Minimal Exudate	Moderate Exudate	Heavy Exudate	Fragile skin or extensive wound
<ul style="list-style-type: none"> • Hydrogel 	<ul style="list-style-type: none"> • Semipermeable film • Hydrocolloid + other polymer • Thin foam 	<ul style="list-style-type: none"> • Foam • Absorbent pad 	<ul style="list-style-type: none"> • Super absorbent pad • Alginate fibre • Gelling fibre 	<ul style="list-style-type: none"> • Wound contact layer or tulle eg silicone mesh • Low adherent • Thin foam

- **Consider other wound features eg:**
 - **cavity** - may need packing, be mindful to avoid putting pressure on tissues or blocking exudate drainage. Use a dressing that does not lose integrity when saturated + can be removed in 1 piece without causing tissue trauma. Always leave a 'tail' of dressing outside the wound
 - **infected** - use antimicrobial dressing for shortest time possible, review after 2 weeks:
 - if infection has resolved change to non-antimicrobial dressing²
 - **malodorous** - more frequent dressing changes + wound cleansing to ↓ odour. Consider debridement, foam dressing or antimicrobial dressing, topical metronidazole gel as per MO/NP/wound specialist
 - **hypergranulation tissue** - if bleeds easily, soft and spongy + exceeds the margins, consider hypertonic saline gauze or foam dressings with silver. Address the moisture, microbial load + ↓ surface friction of the dressings
 - **pain** - dressings with silicone are often comfortable + can be removed with minimal trauma eg foams with a silicone contact surface or a silicone wound contact layer
- Apply a secondary dressing if needed for absorption/protection + consider protecting skin around the wound eg cleanse with pH appropriate skin cleanser, avoid soap
- Most dressings do not need to be changed until at least 75% saturated
- Reassess dressing regime within a week + then at each dressing change. Unless there is a clear

problem eg pain, excessive exudate, do not alter regime for at least 2 weeks or as per MO/NP/wound specialist

- Advise patient about wound healing as indicated:²
 - general dietary advice, protein + energy requirements are higher for chronic wounds. Consider/offer referral to dietitian
 - cigarette smoking can delay healing + ↑ risk for infection. Encourage to stop at each review

5. Follow up

- As per MO/NP/wound specialist or podiatrist

6. Referral/consultation

- As above

Swollen/painful joints

HMP Acutely swollen/painful joint - adult

Recommend^{1,2}

- The causes can be difficult to diagnose. Be suspicious of septic arthritis (an orthopaedic emergency), acute osteomyelitis + [ARF, p. 515](#)

1. May present with¹⁻³

- Painful, red + swollen joint(s) ± fever, malaise

2. Immediate management¹

- Vital signs
- Screen for [Sepsis, p. 64](#)

3. Clinical assessment^{1,2}

Red flags^{1,2}

- Acute swelling, redness and marked ↓ in range of motion of joint
- Systemic symptoms eg ↑ HR, fever, malaise, night sweats, weight loss³
- Recent joint surgery
- Recent injury/wound (can be minor)

- Get history, including:
 - pain - sudden or gradual onset
 - past episodes ± diagnosis
 - ARF/RHD diagnosis or family history of¹
 - other symptoms eg fatigue, skin infection, sore throat³
 - IV drug use²
- Examine joints:
 - swelling, tenderness, warmth + mobility
 - if the pain seems out of proportion to the joint signs - consider [ARF, p. 515](#)
- Check for swollen lymph nodes

4. Management^{1,2}

- Be suspicious of septic arthritis, acute osteomyelitis and [ARF](#), p. 515
- If highly suggestive of gout, see [Gout](#), p. 326
- If suspected sprain/soft tissue injury, see [Sprains/soft tissue injury](#), p. 159
- Offer analgesia. See [Acute pain](#), p. 32
- Contact MO/NP if any **Red flags**, who may advise:
 - blood cultures, IV antibiotics
 - x-ray
 - evacuation/hospitalisation ± referral to orthopaedic specialist

5. Follow up

- As per MO/NP

6. Referral/consultation

- As above

HMP **Gout** - adult

Background

- Gout occurs from deposits of urate crystals in the body. Causes joint pain + swelling¹

1. May present with^{1,2}

- Painful, red + swollen joint(s) eg big toe, knee
- Attack of gout

2. Immediate management Not applicable

3. Clinical assessment^{1,2}

- Get history, including:
 - previous diagnosis, past episodes of gout + treatment eg urate lowering medicines
- Vital signs
- Examine joint(s) for swelling, tenderness, warmth and mobility:²
 - hard nodules over elbows, knees + feet may indicate chronic gout¹

4. Management^{1,2}

- Always consider another cause of the pain. See [Swollen/painful joint](#), p. 325
- Consult MO/NP if:
 - systemic symptoms eg ↑ HR, fever, malaise, night sweats, weight loss
 - first attack of gout (can mimic septic arthritis, an orthopaedic emergency¹)
 - re-presentation for this attack
- If acute attack of previously diagnosed gout, offer short-term pain relief:¹⁻³
 - NSAID eg ibuprofen or indomethacin for 3–5 days. See [Acute pain](#), p. 32
 - **OR** colchicine as a single 1 day course (start as soon as possible)³

S ₄	Colchicine			Extended authority
ATSIHP, IHW, IPAP and RN must consult MO/NP				
RIPRN may proceed				
Form	Strength	Route	Dose	Duration
Tablet	500 microg	Oral	1 mg then 500 microg 1 hour later	stat
Offer CMI: May take up to 48 hours for inflammation to subside. May cause diarrhoea, nausea, abdominal discomfort, vomiting, sore throat, rash or GI bleeding. If already taking colchicine wait at least 12 hours before next dose				
Note: If renal or hepatic impairment, seek MO/NP advice				
Contraindication: Blood dyscrasias, severe GI disease, corneal wounds or ulcers				
Management of associated emergency: Consult MO/NP. See Anaphylaxis, p. 82				

1,3

5. Follow up

- Advise to be seen at next MO/NP clinic for ongoing management

6. Referral/consultation

- As above

Mosquito borne diseases

HMP Mosquito borne diseases - adult/child

Dengue fever, Ross River virus, Barmah Forest virus, malaria

Recommend

- Consider testing for mosquito borne diseases if fatigue, malaise + joint pain where other causes have been excluded
- Have a low threshold for malaria testing from January to June (inclusive) in the Torres Strait¹

Background

- Most common Australian mosquito borne diseases include Ross River virus (RRV), Barmah Forest virus (BFV) + dengue (only in tropical regions + local transmission can occur if the virus has been introduced by an infected person who has returned from endemic countries)²⁻⁴
- Also see *Mosquito borne diseases* <https://www.health.qld.gov.au/clinical-practice/guidelines-procedures/diseases-infection/diseases/mosquito-borne/resources>

1. May present with

- Flu-like symptoms eg fever, painful/swollen joints, headache, fatigue, rash^{3,4}
- Probable dengue** if patient resides in or travelled to endemic area, has a fever + 2 of the following:²
 - headache
 - nausea, vomiting
 - arthralgia, myalgia (joint/muscle aches and pains)
 - rash
- Consider malaria**¹ if travelled to endemic area or reside in Torres Strait +
 - fever > 38 if adult or > 38.5 if child + no other obvious cause of fever
 - fever 'attacks' - abrupt onset of uncontrollable shivering + within an hour or so high fever

- develops, followed by profuse sweating as fever subsides a few hours later
- between attacks there are few other symptoms
- other common symptoms - vomiting, diarrhoea, muscle pains, abdominal pains
- severe malaria can occur if untreated eg cerebral malaria, severe anaemia, renal failure, shock

2. Immediate management Not applicable

3. Clinical assessment

If probable dengue²

- **Notify Public Health Unit immediately** upon clinical suspicion
- Check for signs of severe dengue:
 - dehydration
 - confusion
 - bleeding eg mouth + gums, heavy menstrual bleeding in females
 - contact MO/NP promptly
- Get travel history + determine if the case was acquired overseas or locally:
 - have they travelled overseas within 2 weeks of onset of symptoms
- Note the date of onset of symptoms, this identifies which diagnostic test to do eg:
 - dengue PCR 0–5 days (advise patient a test for Zika will also be done by pathology)
 - NS1 antigen 0–9 days
 - IgM - from day 5 onwards
 - IgG - from day 8 onwards
 - also take LFT and FBC (↓ WCC, ↓ platelets and altered LFT suggest dengue) +
 - note the date of onset of symptoms + if recent overseas travel on the pathology form

If malaria suspected¹

- Ask about:
 - travel (especially PNG) in prior 3 months
 - date first became ill (fever)
 - recent antibiotic or antimalarial use
- Do pregnancy test if female of reproductive age
- **Consult MO/NP**, who may advise:
 - rapid diagnostic test (i-STAT) (if negative, also test for dengue)
 - 2 thick and thin blood malaria smears
 - FBC, parasite count (at least 2 mL adult, 1 mL child)
 - UC, LFT, BGL, malaria antigen test

If suspected Ross River virus (RVV) or Barmah Forest virus (BFV)^{3,4}

- Ask about:
 - arthralgia/arthritis of the wrists, knees, ankles + small joints of extremities
 - pins + needles and tenderness of the palms + soles
 - fatigue + malaise - often prominent in RRV
 - rash on trunk + limbs - common in BFV
- Do physical examination, including:
 - check for rash
 - palpate joints for pain/swelling
 - check for swollen lymph nodes

4. Management

Dengue²

- Ongoing management as per MO/NP ± evacuation/hospitalisation if severe
- Public Health Unit will monitor + advise on public health interventions
- There is no specific treatment. Aim to relieve symptoms:
 - offer paracetamol. See [Acute pain, p. 32](#)
 - **note:** avoid NSAID + aspirin - may aggravate bleeding
 - if dehydrated, IV sodium chloride 0.9%
 - encourage oral fluids + bed rest
 - recovery is usually < 1 week + not prolonged
- Provide personal protection advice:
 - stay in screened accommodation + have someone stay home to look after them
 - if family members/associates develop a fever present/return immediately
 - patient + household members should use insect repellent during daylight hours
 - household members should take measure to avoid being bitten, especially while patient is febrile

If malaria suspected¹

- Consult MO/NP and Public Health Unit who will advise management, including:
 - presumptive treatment as per local guidelines, as soon as blood film taken
 - **note:** guidelines for Torres Strait <https://www.health.qld.gov.au/clinical-practice/guidelines-procedures/diseases-infection/diseases/mosquito-borne/resources>

If likely RRV or BFV^{3,4}

- Consult MO/NP who may advise:
 - testing/bloods
 - ongoing management
- No specific treatment, offer NSAID if joint pain. See [Acute pain, p. 32](#)
- Advise patient if:
 - RRV - can have prolonged symptoms, up to a year in some cases
 - BFV - recovery usually in several weeks, symptoms may persist > 6 months

In all cases advise preventive measures²⁻⁴

- The best prevention is to avoid mosquito bites by:
 - avoiding outdoor activities when mosquitoes are most active, around dawn and dusk
 - wearing loose, light-coloured clothing with long sleeves, long trousers + socks (mosquitoes can bite through tight-fitting clothes)
 - use protective mosquito repellent containing diethyl toluamide (DEET) or picaridin + reapply as directed by the manufacturer. Lotions + gels are more effective + longer lasting than sprays
 - ensure fly screens + water tank screen are in good order + use mosquito lanterns, coils or plug-in repellent devices
 - emptying containers holding water around the house weekly

5. Follow up

- As per MO/NP/Public Health Unit
- If dengue, advise to return if develop severe symptoms - contact MO/NP urgently

6. Referral/consultation¹

- Notify Public Health Unit ☎ if probable or diagnosed dengue or if confirmed malaria, RRV or BFV

Chronic conditions

HMP Secondary prophylaxis for acute rheumatic fever (ARF) - adult/child

Recommend¹

- Strict regular long-term benzathine benzylpenicillin (Bicillin LA®) prophylaxis (**every 21–28 days**) is critical to prevent recurrent Group A Strep infections causing ARF, p. 515
- **Every day of non-treatment over 28 days puts the person at high risk of recurrence of ARF**

Background¹

- Recurrent ARF can lead to a chronic condition called rheumatic heart disease (RHD) which involves deformity and dysfunction of the heart valves
- The RHD Register and Control Program Qld maintains Bicillin LA® and echo registers + is available for clinical support and education ☎ 1300 135 854 ArfRhregister@health.qld.gov.au
 - if outside of Qld contact your state/territory RHD control program
- Recommended resources. See <https://www.rhdaustralia.org.au/resources>
 - *The 2020 Australian guideline for prevention, diagnosis and management of acute rheumatic fever and rheumatic heart disease* (3rd edition)
 - eLearning - *Administering Bicillin*

1. May present with

- History of ARF
- Diagnosis of rheumatic heart disease (RHD)

2. Immediate management Not applicable

3. Clinical assessment

- Check and complete care items on the patient's ARF/RHD care plan
- Ask:
 - **date of last Bicillin LA® injection** - check medical record, or
 - contact RHD Register ☎ 1300 135 854 (Qld), or state/territory RHD control program
 - **note:** Qld Health viewer medication tab is updated within 24 hours of injection being entered into the register
 - **if any problems** after previous injection(s)
 - **where patient wants injection:**¹
 - ventrogluteal preferred site; lateral thigh is acceptable
 - **note:** upper outer quadrant of the buttock is associated with sciatic nerve damage and must be used with caution

4. Management¹

- The duration of secondary prophylaxis is a specialist decision based on a number of individual and environmental factors. Prophylaxis can only be ceased by a specialist MO
- **Injections can be given anytime between 21–28 days:**
 - a specialist may recommend a 21 day regimen (rather than 21–28 days) for patients who have breakthrough ARF despite complete adherence to a 28 day regimen OR have a high level of risk eg severe RHD, OR a history of heart valve surgery

- **Give benzathine benzylpenicillin (Bicillin LA®):**
 - consider strategies for [Managing injection pain](#), p. 563
 - if allergic to penicillin, specialist will order oral erythromycin
- If patient has bleeding problems after injections or consistently declines Bicillin LA® despite attempts to identify and address any barriers to injections:
 - specialist may order oral phenoxymethylpenicillin
- **If oral antibiotics given:**
 - advise ArFRhdregister@health.qld.gov.au (or state/territory RHD control program) date supplied
 - emphasise consequence of missed doses + encourage to consider returning to injections
 - ↑ monitoring for Group A Strep infections eg [Impetigo](#), p. 298, [Sore throat](#), p. 495 and recurrence of [ARF](#), p. 515

S ₄	Benzathine benzylpenicillin (Bicillin LA®)			Extended authority ATSIHP/IHW/IPAP/RIPRN
ATSIHP, IHW, IPAP and RN must consult MO/NP (or have current medication order)				
RIPRN may proceed				
Form	Strength	Route	Dose	Duration
Prefilled syringe	1.2 million units/2.3 mL	IM	Child < 20 kg 600,000 units (1.2 mL)	Once every 21–28 days Inject slowly over at least 2–3 minutes
			Adult and child ≥ 20 kg 1.2 million units (2.3 mL)	
Offer CMI: May cause diarrhoea, nausea and pain at injection site				
Note: Ventrogluteal , p. 564 or vastus lateralis sites preferred. Do not give in deltoid				
Contraindication: Severe or immediate allergic reaction to a penicillin. Be aware of cross-reactivity between penicillins, cephalosporins and carbapenems				
Management of associated emergency: Ensure access to adrenaline (epinephrine) 1:1,000 to treat anaphylaxis eg if giving in patients home. Consult MO/NP. See Anaphylaxis , p. 82 ^{1,2}				

S ₄	Erythromycin			Extended authority ATSIHP/IHW/IPAP/RIPRN
ATSIHP, IHW, IPAP and RN must consult MO/NP (or supply on current medication order)				
RIPRN may proceed				
Form	Strength	Route	Dose	Duration
Capsule	250 mg	Oral	Adult and child 250 mg bd	Ongoing on specialist advice
Oral liquid	200 mg/5 mL			
Offer CMI: Take on an empty stomach 1 hour before or 2 hours after food. May cause nausea, vomiting, diarrhoea, abdominal pain/cramps or thrush. Can be taken with food if causes stomach upset				
Note: If renal impairment seek MO/NP advice. Interacts with many medicines, including over-the-counter and herbal products. Use with caution in patients with myasthenia gravis				
Contraindication: Use with some statins. Severe or immediate allergic reaction to macrolides. Severe hepatic impairment				
Management of associated emergency: Consult MO/NP. See Anaphylaxis , p. 82 ^{1,4}				

S4	Phenoxymethylpenicillin			Extended authority
ATSIHP, IHW, IPAP and RN must consult MO/NP (or supply on current medication order) RIPRN may proceed				
Form	Strength	Route	Dose	Duration
Capsule	250 mg	Oral	Adult and child 250 mg bd	Ongoing on specialist advice
Oral liquid	125 mg/5 mL 250 mg/5 mL			
Offer CMI: May cause diarrhoea, nausea or thrush. Food has little effect on absorption				
Contraindication: Severe or immediate allergic reaction to a penicillin. Be aware of cross-reactivity between penicillins, cephalosporins and carbapenems				
Management of associated emergency: Consult MO/NP. See Anaphylaxis, p. 82				1,3

5. Follow up¹

- Use strategies to support patient to return for next injection eg:
 - reschedule next appointment before they leave the clinic
 - update recall for 21 days time
 - fill out injection reminder card <https://www.rhdaustralia.org.au/resources/injection-reminder-cards>
 - encourage to download *Treatment tracker* App <https://www.rhdaustralia.org.au/treatment-tracker-app>
- Provide ongoing support and education eg *Strong Heart Strong Body* book <https://www.rhdaustralia.org.au/file/1587/view>

6. Referral/consultation

- Inform ArfRhregister@health.qld.gov.au (or state/territory RHD control program) of date of injection in order to update prophylaxis management dates

HMP Supply of chronic condition medicines by A&TSIHP and IHW

Recommend

- This HMP is for Aboriginal and Torres Strait Islander Health Practitioners (A&TSIHP) and Authorised Indigenous Health Workers (IHW) to supply medicines for ongoing management of chronic conditions in isolated practice areas. Isolated practice areas are defined in the *Medicines and Poisons (Medicines) Regulation 2021* <https://www.health.qld.gov.au/system-governance/licences/medicines-poisons/medicines-poisons-act/legislation-standards>
- This topic is not intended for assessment and treatment of acute conditions

Background

- A&TSIHP and IHW may be required to supply medicines prescribed by an MO/NP for chronic conditions if < 6 months since last medical consultation^{1,2}

1. May present with

- Diagnosis of chronic condition and medicine(s) prescribed by MO/NP
- Patient requesting supply of medicines for chronic condition eg for ongoing management of:
 - diabetes
 - asthma
 - hypertension

- COPD
- chronic heart disease
- chronic kidney disease

2. Immediate management Not applicable

3. Clinical assessment^{1,2}

- Check order for medicine is current and written within last 6 months
- Check medicine is approved for supply (ie ‘give a treatment dose’) by the clinician - it will be listed in Appendix 3 ‘Chronic Disease Medicines’ of the relevant Extended Practice Authority(EPA):
 - EPA - **Aboriginal and Torres Strait Islander Health Practitioners** OR
 - EPA - **Indigenous Health Workers**
 - access EPAs at <https://www.health.qld.gov.au/system-governance/licences/medicines-poisons/medicines-poisons-act/legislation-standards>

Where practical, check and complete actions according to the patient’s care plan at the time of supply. Refer to the *Chronic conditions manual* for guidance <https://www.health.qld.gov.au/rrcsu/clinical-manuals/chronic-conditions-manual-ccm>

- Ask how patient is going with medicines:
 - are they taking the medicine as prescribed; any difficulties taking
 - any side effects
 - any other concerns
- Check medicine allergies

If medicine(s) is for management of diabetes:

- Check BGL
- If BGL is outside of normal ranges, consult MO/NP for advice
- Check and complete care items on diabetes and high risk foot care plan(s)

If medicine(s) is for management of hypertension:

- Check BP
- If BP is outside of normal ranges, consult MO/NP for advice
- If systolic BP ≥ 200 \pm diastolic BP ≥ 130 , contact MO/NP urgently. See [Hypertensive emergency, p. 116](#)
- Check and complete care items on hypertension care plan

If medicine(s) is for management of asthma:

- As appropriate, check inhaler technique
- Discuss smoking and passive smoking (if applicable)
- Ensure patient has an Asthma Action Plan
- Check and complete care items on asthma care plan

If medicine(s) is for management of chronic obstructive pulmonary disease (COPD):

- As appropriate, check inhaler techniques
- Discuss smoking and passive smoking (if applicable)
- Check and complete care items on COPD care plan

If medicine(s) is for management of chronic kidney disease (CKD):

- Check and complete care items on CKD patient care plan according to stage of kidney disease

If medicine(s) is for management of chronic heart disease (CHD):

- Check and complete care items on chronic heart disease care plan

4. Management

Offer health education/support for management/prevention of the chronic condition as relevant eg:

- Smoking cessation
- Healthy eating
- Alcohol intake
- Exercise

Refer to the *Chronic conditions manual* for guidance <https://www.health.qld.gov.au/rrcsu/clinical-manuals/chronic-conditions-manual-cm>

- Consult MO/NP if:
 - condition is worsening or not managed well with medicines
 - BGL or BP remains elevated; shortness of breath; any other concerns for their health
 - patient has any concerns about their medicine
 - any concerns about reading the medicine order
 - any concerns or you are unsure about anything
- Check non-inpatient rural and remote medication chart for medication order:
 - check date order written - A&TSIHP and IHW may only supply if order is within last 6 months
 - can you read the order properly
 - is the medicine in stock
 - when did the patient last get the medicine
- Select medicine for supply according to MO/NP order:
 - check the generic name of the medicine - ensure patient is not already taking the same medicine with a different brand name
 - if patient requests more than 1 months supply, contact MO/NP for approval
 - label appropriately
 - record supply
- Offer consumer medicine information as appropriate including:^{1,2}
 - how to take the medicine
 - what it is for and how it works
 - warnings/precautions, such as when the medicine should not be taken
 - common side effects
 - how to store

5. Follow up

- Discuss need for next MO/NP appointment as appropriate

6. Referral/consultation

- If concerned condition is worsening or not managed well with medicines, consult MO/NP
- Refer as appropriate eg to diabetes educator, dietician, exercise physiologist, podiatrist, physiotherapist
- Support patient to access specialist appointments

Mental health and alcohol withdrawal

Mental health

HMP Mental health emergency - adult/child Acute severe behavioural disturbance (ASBD)

Recommend

- Key Qld resources required to support clinicians during a mental health emergency <https://www.health.qld.gov.au/clinical-practice/guidelines-procedures/clinical-staff/mental-health/act/policies-guidelines>
- If outside of Qld, refer to local policies + procedures
- In Qld, a member of the public with concerns for the mental health of a person can contact the police, ambulance or the Mental Health Review Tribunal (MHRT) for further intervention <https://www.mhrt.qld.gov.au/information-about/examination-authorities>

1. May present with^{1,2}

- Violent behaviour or extreme agitation
- Self-destructive, physically or verbally aggressive or threatening behaviour
- Possession of a weapon with intent to use
- Bizarre, disorientated behaviour:
 - unable to stand still
 - inappropriate anger or sadness
- Hallucinations:
 - ordering person to harm themselves
 - seeing, hearing or feeling things that are not there
 - talking to people who are not there
- Delusions:
 - suspicious of people or things in surroundings
 - grandiose thoughts
- Withdrawn eg refusing to talk or eat
- Current suicide attempt, or:
 - expresses intent to die
 - has a plan in mind
 - has access to lethal means
- Situational crisis
- Family member seeking help for any of the above

- In Qld, if a **police or ambulance officer** presents with an involuntary patient, they must:^{3,6,7}
 - seek approval from the Director of Nursing/person in charge prior to bringing patient in
 - complete **Part A** of an *Emergency Examination Authority* (EEA) form, then give to doctor or clinician to complete **Part B**
- Patient can be detained for 6 hours after an EEA is completed to undertake examinations

2. Immediate management

- DRSABCD
- **If person has survived an attempted suicide or a self-harm event, manage accordingly:**
 - eg hanging see [Traumatic injuries, p. 134](#), [Spinal injuries, p. 147](#)
- Consider injuries consistent with self-harm attempt

Stay safe^{1,2}

- Never approach a patient who has a weapon
- If needed take protective measures eg lock yourself in the pharmacy, leave the facility
- Consider risks in the immediate environment eg access to knives, scissors, IV poles
- Note exits for escape
- Remove other people and bystanders
- Assess in an open space
- Minimise distractions + give full attention to the patient
- Use a calm, confident manner, avoid sudden or threatening gestures
- Avoid prolonged eye contact, and do not confront, corner or stand over the patient
- Be familiar with duress alarms

Then

- Phone police if concerned about safety
- Phone MO/NP urgently
- Ensure at least 2 staff are on hand at all times
- Always remain with patient unless your safety is at risk

If required attempt de-escalation^{1,2}

- Listen. Allow patient to speak without interruption
- Be empathic, non-judgemental + respectful
- Monitor changes in mood or composure that may lead to aggression
- Continually show respect + empathy for patient
- Identify any patient needs that have not been met
- Use a slow, clear + steady voice + do not raise your voice
- If the patient raises their voice, pause + listen to the patient vent their frustrations
- For children, consider removing people who may be the source of violent or aggressive behaviour

Never undertake physical restraint

- Rural and remote facilities lack the resources to undertake this procedure safely
- As a matter of urgency staff are to:
 - call the police (000)
 - protect themselves + others - retreat from the situation
- If restraint is to be used, it should be undertaken in accordance with Qld state-wide policy³ <https://www.health.qld.gov.au/clinical-practice/guidelines-procedures/clinical-staff/mental-health/act/policies-guidelines>

3. Clinical assessment

For non-consenting or uncooperative patient (Qld)^{1,4,5}

- Forms are required by law before examination or treatment
- **If brought in by police or ambulance** under an *Emergency Examination Authority* (EEA):
 - examination of patient can be done for 6 hours
 - can be extended to 12 hours if needed
 - involuntary detention under the EEA expires after the 12 hours or examination is complete
 - if patient requires further examination then complete a *Recommendation for Assessment* (RA)
- **If patient presents otherwise (eg with family):**
 - a doctor or **authorised** mental health practitioner, who believes the patient may have a mental health condition, needs to complete a *Recommendation for Assessment* (RA) form (via Telehealth if required):^{1,4,5}
 - patient can be detained for 1 hour before form completed
 - the RA authorises involuntary detention for 7 days
 - keep copy in records + send copy with patient (if evacuated)

If police assistance is required (Qld)

- If patient absconds under an *Emergency Examination Authority* (EEA) +
 - they are at risk of harm to themselves or others, call 000 for urgent police assistance + any health practitioner can complete a *Public Health Act 2005 Request for Police Assistance* form
 - they are not at risk of harm to themselves or others, clinician should attempt to contact and encourage them to return voluntarily
- If patient under a *Recommendation for Assessment* (RA) and police assistance needed eg to examine, treat, or transport:
 - a doctor or **authorised** mental health practitioner can complete a *Mental Health Act 2016 Request for Police Assistance* form

- Get history, including:
 - current mental health management plan and related presentations^{1,2}
 - establishing patient's behaviour + personality prior to the current presentation. Via family + friends if needed^{1,2}
- Do vital signs+
 - BGL + SpO₂ to exclude glycaemic + hypoxic causes of behaviour change^{1,2}
- Do physical examination - consider injuries consistent with self-harm attempt
- Do a **Mental State Examination (MSE)**. See following box for observations + example questions
- **For children**, assess for sudden or significant, unexplained changes of behaviour or emotional state such as:^{1,2}
 - unusual fearfulness or severe distress eg inconsolable crying
 - self-harm or social withdrawal
 - aggression or running away from home
 - indiscriminate attention seeking with adults
 - development of new behaviours eg soiling or wetting, thumb sucking
- Consider alternate cause where child presentation is inconsistent with history. See [Child protection, p. 551](#)

Mental State Examination (MSE) observations and example questions ^{6,7}	
Appearance	<ul style="list-style-type: none"> Gender, ethnicity, apparent age, clothing, grooming, hygiene + cultural appropriateness
Behaviour	<ul style="list-style-type: none"> Agitation, aggression, eye contact, cooperativeness, motor activity, retardation, inappropriate or unusual behaviour
Speech	<ul style="list-style-type: none"> Rate, rhythm + volume of speech. Is it spontaneous
Mood	<ul style="list-style-type: none"> Ask patient to describe their mood eg elevated, depressed, labile, angry, happy
Affect	<ul style="list-style-type: none"> The outward appearance of the patient's emotional state eg blunted, flattened, euphoric, anxious
Perception	<ul style="list-style-type: none"> Auditory or non-auditory hallucinations Does the patient believe the hallucinations or voices are real What are the voices saying. Commands to harm self or others. Has the patient responded to the voices
Thought form	<ul style="list-style-type: none"> Are the patient's ideas or thoughts connected in a strange or illogical fashion. Record some quotes of the patient's speech Is the patient incoherent, use words that rhyme or have secret meanings different to actual meaning
Thought content	<ul style="list-style-type: none"> Explore anxieties, obsessions, preoccupations and delusions ie patient is certain their ideas are reasonable despite being grandiose, persecutory or bizarre eg television is talking to them Does patient think their concerns are excessive Are beliefs different to cultural and religious background
Judgement	<ul style="list-style-type: none"> Assess patient's capacity for responsible decision making eg to care for children
Insight	<ul style="list-style-type: none"> Does the patient acknowledge their symptoms, diagnosis or need for treatment
Cognition	<ul style="list-style-type: none"> Orientation to time, person and place Memory, attention and ability to concentrate ie need for redirection or repeating Alert, drowsy, delirium, stupor Impression of current abilities, awareness to confusion of self

4. Management

- Once imminent risk of harm to themselves or others has been addressed, refer to relevant presentation:
 - Suicidal behaviour, p. 344
 - Psychosis, p. 350
 - Mood disorders, p. 352
 - Panic attack, p. 354
 - Dementia, p. 348
 - Delirium, p. 131
- Manage in consultation with MO/NP + psychiatrist or Mental Health Team
- Only consider sedation** (see flowchart on next page):^{1,3,5}
 - if attempts at de-escalation have been exhausted
 - to control severe behaviour disturbance for patient's safety + safety of others
 - to allow diagnostic assessment + management
 - to relieve patient distress
 - **if child, adolescent or medically frail** patient - after consultation with MO/NP or psychiatrist
 - for **eligible adults only**, see Qld Health sedation policy https://www.health.qld.gov.au/__data/assets/pdf_file/0031/629491/qh-gdl-438.pdf

Sedation for Acute Severe Behavioural Disturbance (ASBD) in adults outside a mental health facility^{1,4}

Have de-escalation techniques been attempted prior to sedation

YES

Notify MO/NP you are proceeding to sedation

Assess need for sedation

Use scale below to assign a single score between +3 and -3 according to the patient's responsiveness and speech

NO

Continue to use de-escalation techniques

Responsiveness	Speech	Score
Combative, violent, out of control	Continual loud outburst	+3
Very anxious and agitated	Loud outburst	+2
Anxious/restless	Normal/talkative	+1
Awake and calm/cooperative	Speaks normally	0
Asleep but rouses if name is called	Slurring or prominent slowing	-1
Responds to physical stimulation	Few recognisable words	-2
No response to stimulation	None	-3

Contact MO/NP who may order:

- IM droperidol or IM ketamine if droperidol fails

Repeat **sedation assessment** every 15 minutes. Aim for score of 0

Continuous SpO₂ + vital signs for all patients receiving IM sedation

Oral diazepam **OR** oral olanzapine

Repeat **sedation assessment** every 30 minutes. Aim for score of 0

No sedation required

Notify MO/NP immediately if:

Adult - SpO₂ < 94%, RR < 10, HR < 50, GCS < 5

Child or adolescent - CEWT score ≥ 2 for any domain

For reversal of benzodiazepine induced respiratory depression give flumazenil

- For family members + relatives of patient, including children:
 - this may be a very frightening experience for them. Provide support
 - consider immediate safety needs of vulnerable people for whom the patient has care responsibilities ie children
 - provide a copy of any management plan

S ₄	Diazepam			Extended authority ATSIHP/IHW/IPAP/RIPRN
ATSIHP, IHW, IPAP and RN must consult MO/NP				
RIPRN may proceed				
Note: if a non-consenting patient, can only be given by an RN or RIPRN + after consultation with MO/NP				
Form	Strength	Route	Dose	Duration
Tablet	2 mg 5 mg	Oral	Adult 10 mg (max. 60 mg/24 hours)	stat Further doses on MO/ NP order
			Medically frail adult 5–10 mg (max. 60 mg/24 hours)	
			Child > 5–adolescent 0.2 mg/kg (max. 10 mg x 2 doses only)	
Offer CMI: May cause drowsiness, oversedation, light-headedness, hypersalivation, ataxia, slurred speech or effects on vision				
Note: Monitor respiratory rate closely. Halve the usual adult dose if elderly ± debilitated. Diazepam tablets can be crushed and mixed into food eg yoghurt/fruit puree or dispersed in 10–20 mL of water				
Contraindication: Drug overdose, myasthenia gravis, severe hepatic impairment				
Management of associated emergency: If respiratory rate < 10 after sedation, reverse with flumazenil. Consult MO/NP. See Anaphylaxis, p. 82 1,4,8				

S ₄	Olanzapine			Extended authority ATSIHP/IHW/IPAP/RIPRN
ATSIHP, IHW, IPAP and RN must consult MO/NP				
RIPRN must consult MO/NP unless circumstances do not allow, in which case notify the MO/NP as soon as circumstances allow				
Form	Strength	Route	Dose	Duration
Tablet or Wafer	2.5 mg 5 mg 10 mg	Oral	Adult only 5–10 mg (max. 30 mg/24 hours)	stat Further doses on MO/NP order (after 60 minutes)
			Medically frail adult 2.5–5 mg (max. 15 mg/24 hours)	
Offer CMI: Caution if moving from lying to sitting or to standing position				
Contraindication: Known allergy; drug overdose				
Management of associated emergency: Give benztropine as an antidote for extrapyramidal side effects eg acute dystonic reaction. Consult MO/NP. See Anaphylaxis, p. 82 1,4,9				

S4	Flumazenil			Extended authority
ATSIHP, IHW, IPAP and RN must consult MO/NP				
RIPRN must consult MO/NP unless circumstances do not allow, in which case notify the MO/NP as soon as circumstances do allow				
Form	Strength	Route	Dose	Duration
Injection	500 microg/ 5 mL	IV	Adult Initial dose 200 microg Further dose(s) 100 microg (max. total dose 1 mg)	stat Inject over 15 seconds Repeat every 60 seconds if necessary to a total dose of 1 mg
Offer CMI: May cause nausea and vomiting				
Note: Use with caution in patients with epilepsy receiving long-term benzodiazepine treatment. Patients may become agitated, anxious or fearful on awakening. Use with caution in those who have mixed overdose of benzodiazepines and proconvulsant drugs - can result in death. Half life approx. 1 hour (much shorter than that of all benzodiazepines) - observe for at least 4 hours after dose				
Pregnancy: Do not use in benzodiazepine dependent women; risk of precipitating withdrawal in fetus				
Management of associated emergency: Consult MO/NP. See Anaphylaxis, p. 82				1,4,10

S4	Droperidol			Prescribing guide
MID, RIPRN and RN only. Must be ordered by an MO/NP				
Form	Strength	Route	Dose	Duration
Injection	10 mg/2 mL	IM	Adult 2.5–10 mg (max. 30 mg/24 hours)	stat May be repeated after 20 minutes
Offer CMI: May cause hypotension, respiratory depression (especially if given with benzodiazepines) or extrapyramidal side effects (rare)				
Note: Monitor patient closely after administration. QT prolongation may occur (rarely clinically significant with doses used for ASBD)				
Management of associated emergency: Give benzatropine as an antidote for extrapyramidal side effects eg acute dystonic reaction. Consult MO/NP. See Anaphylaxis, p. 82				1,4,11

S4	Benzatropine			Extended authority
ATSIHP, IHW and RN must consult MO/NP				
RIPRN may proceed				
Form	Strength	Route	Dose	Duration
Tablet	2 mg	Oral	Adult only 1–2 mg	stat
Injection	2 mg/2 mL	IM		Further doses on MO/NP order
Offer CMI: May cause drowsiness, dizziness or blurred vision. May increase effects of alcohol				
Contraindication: GIT or urinary obstruction, myasthenia gravis				
Management of associated emergency: Consult MO/NP. See Anaphylaxis, p. 82				1,4,12

5. Follow up

- If referred to the Mental Health Team:
 - see **Mental Health Team response time** table below for expected response + action times

Mental Health Team response time ^{13,14}			
Urgency	Typical presentation	Response time	Actions may include
Emergency	<ul style="list-style-type: none"> • Actions endangering self or others • Overdose • Suicide attempt • Violent, aggression • Possession of a weapon 	Immediate	<ul style="list-style-type: none"> • Face to face • Videoconference • Telehealth • Telephone support • Police involvement
Very high	<ul style="list-style-type: none"> • Suicidal ideation with risk of harm with clear plan • Thought disturbance • Delirium • Dementia • Impaired impulse control 	Within 4 hours	<ul style="list-style-type: none"> • Face to face • Videoconference • Telehealth • Telephone support
High	<ul style="list-style-type: none"> • Suicidal ideation, no plan • Rapid increase in symptoms of psychosis or severe mood disorder • Overt unprovoked aggression • Wandering at night • Vulnerable isolation or abuse 	Within 24 hours	<ul style="list-style-type: none"> • Same day contact • Videoconference • Telehealth • Telephone support
Moderate	<ul style="list-style-type: none"> • Significant patient/carer distress associated with severe mental illness • Not suicidal • Early symptoms of psychosis • Obstructing care • Wandering • Failing carer 	Within 72 hours	<ul style="list-style-type: none"> • Videoconference • Telehealth • Telephone support
Low	<ul style="list-style-type: none"> • Stable and low risk of harm • Able to be managed in the community • Requires non-urgent review adjustment of treatment • Service review • Carer support 	Within 4 weeks	<ul style="list-style-type: none"> • Videoconference • Telehealth • Telephone support

6. Referral/consultation

- Consult MO/NP as above
- Refer for further mental health assessment by psychiatrist or Mental Health Team
- Always consider referral to child protection agencies for:
 - a child presentation
 - a child in care of the patient
 - see [Child protection, p. 551](#)

Suicidal behaviour - adult/child

1. May present with^{1,2}

- Verbalises suicidal ideas/suicidal intent
- Previous presentations for suicidal thoughts or deliberate self-harm
- A recent psychosocial stressor or loss eg grief, relationship breakdown, loss of job, pregnancy or new birth
- Feelings of helplessness or hopelessness

2. Immediate management¹

- DRSABCD
- **Do not leave patient alone**
- **If person has survived an attempted suicide or a self-harm event, manage accordingly**
- Consider injuries consistent with self-harm attempt eg for hanging, see [Traumatic injuries, p. 134](#), [Spinal injuries, p. 147](#)
- If the patient is highly agitated, expressing an intent to suicide, aggressive or violent. See [Mental health emergency, p. 336](#)

3. Clinical assessment¹

- **Ensure patient has an opportunity to discuss their suicidality alone**
- **With consent** seek information from patient's family, friends, support person or others

Communication skills¹

- Listen. Allow patient to speak without interruption
 - Develop and maintain rapport with the patient
 - Be mindful of your own values and beliefs in relation to suicide
 - Convey a sense of warmth, non-judgemental acceptance, and an interest in understanding the patient and the cause of their emotional distress
 - Be respectful and empathic
 - Avoid minimising the seriousness of the risk of suicide
- Ask **Questions about suicidal thoughts:**^{2,4}
 - it is important to ask the person directly about feelings or thoughts of suicide
 - asking about self-harm does not provoke acts of self-harm⁴
 - discuss the balance of confidentiality versus notifying others to ensure safety

Questions about suicidal thoughts¹⁻⁴

Suicide risk

- When people feel like you are/have been feeling, they sometimes think that life is not worth living. Have you been thinking like that or have you ever thought like that
- Have you been thinking of harming yourself
- Are you thinking of suicide
- If yes, how often are you having these thoughts:
 - have you thought about how you would act on these. Is there a plan. Does this plan seem feasible. Are the methods available. Is it likely to be lethal
 - have you thought about when you might act on this plan
 - are there any things/reasons that stop you from acting on these thoughts
- Have you tried to harm yourself in the past:
 - if yes, how many times
 - when was the most recent time
- Do you know anyone who has recently tried to harm themselves
- Do you feel safe at the moment

If a suicide attempt has been made

- What did you hope would happen as a result of your attempt. Did you want to die, or end your pain
- Do you regret that you did not succeed
- Do you still have access to the method used
- Did you use alcohol or drugs before the attempt. What did you use
- Do you have easy access to a weapon

Risk of harm to others

- Have you thought of hurting anyone else:
 - if yes, have you acted on these thoughts
- Have you been involved in any fights recently:
 - if yes, were you using drugs or alcohol at the time

- Consider factors that may be contributing to current thoughts (if patient comfortable and clinician experienced to do so):^{1,2}
 - current mental health management plan and related presentations
 - behaviour and personality prior to presentation
 - childhood abuse, neglect, exposure to traumatic events
 - recent self-harm episodes or suicides in the community (suicide clusters)
 - recent, ongoing or unresolved loss or grief
 - physical or sexual abuse
 - family conflict, domestic violence. See [Domestic and family violence, p. 241](#)
 - school difficulties
 - problems with peers
 - bullying
 - substance misuse
- Do a [Mental State Examination, p. 339](#) +
 - vital signs and physical examination as required
 - risk assessment:
 - depressive symptoms. See [Mood disorders, p. 352](#)
 - neglect or victimisation by others
 - harm to others especially children in patient's care

- Determine suicidal intent (flowchart below)

Determining suicidal intent^{1,2,4}

Patient strengths

- Therapeutic relationship between clinician and patient
- Family warmth, support and acceptance
- Willingness to access and engage with professional help
- Activities/hobbies that an individual finds meaningful
- Community support and cultural identity
- Having children and child rearing responsibilities
- Sense of belonging and connection
- Skills in coping and problem solving, conflict resolution and non-violent ways of handling disputes

Risk factors

- Mental health issues eg depression
- Gender (male)
- Relationship or family problems, violence, abuse or custody issues, pregnancy
- Substance misuse
- Social or geographical isolation
- Aboriginal and Torres Strait Islander
- Financial stress, unemployment, impending court case
- Recent bereavement
- Prior suicide attempt
- Bullying, sexual assault, torture, or refugee status
- Losing a friend or family member to suicide

Warning signs

- Hopelessness
- Feeling trapped
- Escalating substance misuse
- Giving away possessions
- Seeking ways to kill oneself ie searching online or buying a means
- Withdrawing from friends, family or society
- Voicing no reason for living, no sense of purpose in life, being a burden to others
- Uncharacteristic or impaired judgement or behaviour
- Verbalising or writing about wanting to die

Tipping points

- Relationship separation
- Loss of status or respect
- Recent death or suicide of relative or friend
- Recent argument at home
- Current abuse or bullying
- Debilitating physical illness, accident or pain

Imminent risk

- Expressed intent to die
- Has plan in mind
- Impulsive, aggressive or anti-social behaviour
- Has access to lethal means

4. Management

- Consult MO/NP who will plan:
 - immediate and ongoing management in the community, or
 - transfer/evacuation for comprehensive management
- If the patient is the primary carer for children or other vulnerable people, consider alternative arrangements for care. See [Child protection, p. 551](#)^{1,4}
- Discuss the patient's behaviour to family or friends to reduce their anxiety or anger towards the patient
- In consultation with MO/NP **assess whether a patient is safe to be managed at home**:^{4,5}
 - acute problems are identified and being actioned
 - patient knows where and how to seek help if suicidal thoughts recur
 - patient is not demented, intoxicated, sedated, delirious or psychotic
 - **'lethal means' counselling** has been undertaken ie working with the patient and their support persons to limit access to a means of suicide until they are no longer at elevated risk:
 - discuss who is responsible for managing lethal means (eg guns, knives, ropes, drugs, medications, poisons, high places) and removing, restricting or limiting access (may include supervision of the patient)
 - discuss if the patient's occupation gives access to lethal means eg council workers accessing pesticides, police officer accessing guns, clinicians accessing medicines
 - discuss who holds and dispenses all medicines in the home
 - consider reduction of prescription medicine quantities to nonlethal amounts
 - if patient has access to a firearm notify the police/Weapons Licensing Branch⁶ at <https://www.police.qld.gov.au/weapon-licensing/mental-and-physical-health>
 - follow up arrangements have been documented with a copy given to the patient and carers
 - a treatment plan has been arranged for current mental health and medical problems
 - a written **Safety Plan** has been provided to both the patient and their support person
- Develop a written **Safety Plan** with the patient. It involves:^{2,4}
 - recognising warning signs and triggers
 - making surroundings safe
 - reminders of reasons to live
 - things that can make them feel strong
 - people and places to connect with
 - family and friends they can talk or yarn with
 - professional support and access
 - safety planning information is available at <https://www.beyondblue.org.au/get-support/beyondnow-suicide-safety-planning>

5. Follow up

- For Mental Health Team follow up response time and action, see **Follow up** under [Mental health emergency, p. 336](#)
- Consult the Mental Health Team/psychiatrist who will plan ongoing management and coordination
- 24 hour access to clinical support should be available to all patients being managed in the community
- Advise the patient to enact their safety plan if the situation deteriorates

6. Referral/consultation

- Always consider referral to child protection agencies for:
 - a child presentation or a child in care of the patient. See [Child protection, p. 551](#)

HMP Dementia - adult

Severe behavioural and psychological symptoms

Recommend

- For ongoing management of dementia see the *Chronic conditions manual* <https://www.health.qld.gov.au/rccsu/clinical-manuals/chronic-conditions-manual-ccm>

1. May present with

- A patient with known dementia +
- Psychosis, agitation or aggression

2. Immediate management

- **DRSABCD**
- If a person is a risk of harm to themselves, others or their behaviour is associated with perceptual or thought disturbance, delirium or impaired impulse control, see [Mental health emergency, p. 336](#)

3. Clinical assessment

- Assess + manage calmly in a quiet area, with a familiar person present
- Get history, including:
 - current mental health management plan + related presentations²
 - patient's behaviour + personality prior to the current presentation
 - alcohol + drug use
- Identify the trigger (**antecedent**):¹
 - side effects or toxicity from medicines
 - signs of infection or presence of wounds eg acute febrile illness + altered mental status
 - herpes simplex virus leading to encephalitis eg headache, seizures, focal neurological signs^{1,2}
 - acute thiamine deficiency eg ocular abnormalities, gait ataxia, inability to concentrate, apathy, impaired awareness of the immediate situation, spatial disorientation, confusion, psychosis + coma^{1,3}
 - environmental stimuli eg temperature extremes, noise
 - unmet needs eg hunger, thirst, warmth
 - patient-carer conflict
 - pain, constipation
 - vision or hearing difficulties
 - separation from family
- What **behaviour** occurred:
 - does behaviour cause significant distress to themselves or others eg verbal aggression, use of a weapon⁴
- What was the **consequences** of the behaviour eg injury, fall
- Consider elder abuse where presentation for non-accidental cause is inconsistent with history or is unexpected in older or vulnerable people
- Do physical examination¹ +
 - vital signs
 - BGL + SpO₂ to exclude glycaemic or hypoxic causes of behaviour change
 - bloods - FBC, TFT, PTH, UE, calcium, vitamin B12, folate, niacin, CHEM20, thiamine
 - urine for MCS + drug screen

- Use table below to distinguish current dementia presentation from an episode of delirium or depression

Distinguishing signs and symptoms of delirium, dementia and depression ⁸			
	Dementia	Delirium Also see Delirium, p. 131	Depression Also see Mood disorders, p. 352
Onset	Chronic, progressive	Acute illness, medical emergency	Rapid over weeks to months, episodic
Course	Stable during day, progresses	Fluctuates hourly	Can be self-limiting, recurrent, or chronic. Worse in morning, improves during day
Duration	Progressive, irreversible	Hours to weeks, resolves with treatment	Months or years, resolves with treatment
Orientation	Impairment progressively worse, loss of ability to recognise function of everyday objects	Disoriented to time and place	Selective disorientation
Memory	Impaired short-term, unconcerned about memory loss	Impaired short-term	May be impaired, concerned about memory loss
Speech	Repetitive, trouble finding words, confabulates	Incoherent, loud, belligerent	Quiet and minimal, can be belligerent, aggressive. Language skills intact
Sleep	Disturbed, day/night reversal	Disturbed, changes hourly	Disturbed, early morning wakening, sleepy during day
Contributing factors	Advancing age, cardiovascular deficits, substance dependence or unknown cause	Infection, drug side-effect, renal failure, head trauma, substance use	Recent or cumulative loss, medicine toxicity

4. Management

- Address any identified triggers eg polypharmacy, pain, UTI
- Consult MO/NP or general physician/geriatrician/psychiatrist who may order:
 - sedation for violence, agitation or aggression.⁴ See [Mental health emergency, p. 336](#)
 - thiamine for suspected thiamine deficiency^{1,3}
- Offer analgesia if indicated. See [Acute pain, p. 32](#)
- Develop a **Behavioural management plan** with patient, carer and family, specifically:
 - access to dangerous items
 - access to exits if patient is wandering
 - over-stimulation eg too many people in house, excessive noise, clutter
 - under stimulation eg lack of activities or items of interest to patient
 - regular exercise
 - limiting access to alcohol or other drug use
- Consider transfer/evacuation for comprehensive management

5. Follow up²

- According to MO/NP. Regular review if commenced on pharmacological management

6. Referral/consultation²

- Geriatrician/psychiatrist/Older Persons Mental Health Team
- Consider the Aged Care Assessment Team (ACAT), via My Aged Care, for assessment of long-term care needs <https://www.myagedcare.gov.au/>

Psychosis - adult

Drug-induced psychosis, schizophrenia, postnatal psychosis, brief psychotic disorder, bipolar psychosis

Background¹

- Psychosis is a general term used when a patient has lost some contact with reality and may have distorted thinking, perception and mood

1. May present with²

- Delusions:
 - firm fixed belief of things that are not true eg the person must harm someone, their baby is the devil
- Hallucinations:
 - seeing or hearing things that are not there eg voices giving commands
- Disturbed sleep, walking or pacing at night
- Very suspicious and paranoid of others
- Family or friends report strange, disruptive or frightening behaviour
- Women in the perinatal period
- Intoxicated
- Also consider [Delirium, p. 131](#) if:
 - disoriented to time and place
 - incoherent, loud, belligerent

2. Immediate management²

- DRSABCD
- **Do not leave patient alone**
- **If person has survived an attempted suicide or a self-harm event, manage accordingly**
- Consider injuries consistent with self-harm attempt eg for hanging, see [Traumatic injuries, p. 134](#), [Spinal injuries, p. 147](#)
- If the patient is highly agitated, expressing an intent to suicide, aggressive or violent. See [Mental health emergency, p. 336](#)

3. Clinical assessment

- Listen. Allow patient to speak without interruption
- Enquire about but do not challenge their thoughts or behaviours
- Develop and maintain rapport with the patient
- Convey a sense of warmth, non-judgemental acceptance, and an interest in understanding the patient's thoughts or behaviours
- Be respectful and empathic

- Avoid minimising their experiences
- Seek information from patient's family, friends, support person or others
- Get history, including:^{2,3}
 - current mental health management plan and related presentations
 - behaviour and personality prior to the current presentation
 - adverse medication event
 - substance use including cigarette use
 - head injury, trauma or seizures
 - STIs
 - other psychiatric disorders
 - diet and exercise
 - if a woman in the perinatal period, assess for:
 - capacity to safely care for her infant (if delivered)
 - quality of mother-infant relationship eg cuddling, eye contact, responding to cues
- Do physical examination +
 - vital signs
 - BGL + SpO₂ to exclude glycaemic or hypoxic causes of behaviour change
 - bloods - FBC, TFT, PTH, UE, calcium, vitamin B12, folate, niacin, CHEM20
 - urine for MCS and drug screen
 - pregnancy test if female of reproductive age
 - [STI/BBV tests, p. 448](#) - HIV and syphilis
- Do [Mental State Examination, p. 339](#)
- Do risk assessments:³
 - depressive symptoms. See [Mood disorders, p. 352](#)
 - suicidal intent. See [Suicidal behaviour, p. 344](#)
 - neglect or victimisation by others
 - harm to others especially children in patient's care

4. Management²

- Patients with psychosis are unlikely to be managed in the community. Consult MO/NP who will:
 - plan immediate management and coordination
 - arrange evacuation for comprehensive management
 - order antipsychotic and sedative medicine as required. See [Mental health emergency, p. 336](#)
 - if psychosis is due to an adverse effect to antipsychotic medication, may advise to cease medication
- Monitor closely if intoxicated
- For women in the perinatal period consult the MO/NP or midwife for further management options
- Provide family support and education

5. Follow up²

- Consult MO/NP, Mental Health Team/psychiatrist who will plan ongoing management and coordination
- For Mental Health Team follow up response time and action, see **Follow up** under [Mental health emergency, p. 336](#)

6. Referral/consultation

- MO/NP and psychiatrist
- Mental Health, Alcohol and Other Drugs (MHAODS) if problem alcohol or drug use
- Social worker if the patient requires counselling or support navigating services
- Refer women in the perinatal period to a midwife
- Consider child health services or Child and Youth Mental Health Services if concerned about welfare of children in care of patient. See [Child protection, p. 551](#)

Mood disorders - adult/child

Depression, bipolar disorders

Background

- For ongoing management of depression, see the *Chronic conditions manual* <https://www.health.qld.gov.au/rccsu/clinical-manuals/chronic-conditions-manual-ccm>

1. May present with

- Existing history of depression, mood disorders or mania

Depression^{1,2}

- Suicidal ideation/attempts. See [Suicidal behaviour, p. 344](#)
- Insomnia or sleep pattern changes
- Appetite changes
- Irritability, low mood, tiredness
- Difficulty concentrating
- Concerns about social problems such as finances or relationships
- Feelings of helplessness or hopelessness
- Use of alcohol or other substances
- Women in the perinatal period

Mania (bipolar)^{1,2}

- Irritable mood or anger
- Elevated mood
- Inflated self-esteem
- Decreased or unable to sleep, active all night
- Pressured speech and racing thoughts
- Excessive goals, plans and activities
- Poor judgement, impulsive and taking risks eg excessive spending, promiscuous behaviour
- Symptoms of psychosis. See [Psychosis, p. 350](#)

2. Immediate management

- DRSABCD
- **Do not leave patient alone**
- **If person has survived an attempted suicide or a self-harm event, manage accordingly**
- Consider injuries consistent with self-harm attempt eg for hanging, see [Traumatic injuries, p. 134](#), [Spinal injuries, p. 147](#)

- If a person is a risk of harm to themselves, others or their behaviour is associated with perceptual or thought disturbance, delirium, dementia or impaired impulse control. See [Mental health emergency, p. 336](#)

3. Clinical assessment

- Listen. Allow patient to speak without interruption
- Develop and maintain rapport with the patient
- Be mindful of your own values and beliefs in relation to mood disorders
- Convey a sense of warmth, non-judgemental acceptance, and an interest in understanding the patient and the cause of their pain or distress
- Be respectful and empathic
- Avoid minimising the seriousness of their presentation
- Get history, including:
 - current mental health management plan and related presentations²
 - establishing patient's behaviour and personality prior to the current presentation, by family and friends if needed²
 - treatment history and engagement with psychotherapy³
 - adherence to medication at the dosages prescribed³
 - recent loss or stressors
 - chronic illnesses
 - physical disorders
 - sleep history, patterns, insomnia
 - if a woman in the perinatal period, assess for:
 - capacity to safely care for her infant (if delivered)
 - quality of mother-infant relationship eg cuddling, eye contact, responding to cues
 - mood using a mood scale eg EPDS, DASS <https://www.psychologytools.com/download-scales-and-measures/>
- Do physical examination +
 - vital signs
 - BGL + SpO₂ to exclude glycaemic or hypoxic causes of behaviour change
 - bloods - TFT, CHEM20, lithium and sodium valproate levels
 - urine for MCS and drug screen
 - pregnancy test if female of reproductive age
- Do [Mental State Examination, p. 339](#) +
 - risk assessment:³
 - suicidal intent. See [Suicidal behaviour, p. 344](#)
 - neglect or victimisation by others

4. Management

- Consult MO/NP and Mental Health Team or psychiatrist who will:
 - plan immediate management and coordination
 - consider evacuation for comprehensive management
- For mania related behaviours consider sedation. See [Mental health emergency, p. 336](#)
- For women in the perinatal period consult the MO/NP or midwife for further management options

5. Follow up

- According to MO/NP and psychiatrist or midwife

- For Mental Health Team follow up response time and action, see **Follow up** under [Mental health emergency](#), p. 336

6. Referral/consultation

- MO/NP and psychiatrist
- Mental Health, Alcohol and Other Drugs (MHAODS) if problem alcohol or drug use
- Social worker if the patient requires counselling or support navigating services
- Refer women in the perinatal period to a midwife
- Consider child health services or Child and Youth Mental Health Services if concerned about welfare of children in care of patient. See [Child protection](#), p. 551

Panic attack - adult/child

Panic disorder, anxiety

Background

- Unless complex or recurrent, most panic attacks will not require mental health intervention
- For ongoing management of anxiety, see the *Chronic conditions manual* <https://www.health.qld.gov.au/rrcsu/clinical-manuals/chronic-conditions-manual-cm>

1. May present with^{1,2}

- History of panic attacks
- Fear they may collapse or die
- Restlessness or feeling ‘keyed up’ or ‘on edge’
- Trembling
- Difficulty concentrating or mind ‘going blank’
- Irritability and racing heart beat
- Feeling like they can’t catch their breath, hyperventilating
- Dizziness
- Sleep disturbance
- Preoccupation about attacks recurring

2. Immediate management

- If the person is too anxious to concentrate consider:
 - a slow breathing technique:²
 - the person breathes in for 4 seconds
 - holds their breath for 2 seconds
 - then breathes out slowly over 6 seconds
 - perform with the person
 - repeat for a minute

3. Clinical assessment

- Get history, including:²
 - personal and family history
 - perform mood scale eg DASS (access online)
 - alcohol and drug use
 - medication use

- symptoms, fears or phobias
- what may be making them anxious. Can occur for no reason
- what does it stop them doing
- what do they fear will happen
- how long have they had the symptoms
- what led them to come today
- Do physical examination +
 - vital signs
 - BGL + SpO₂ to exclude glycaemic or hypoxic causes of behaviour change
 - ECG
 - bloods - TFT, UE, FBC

4. Management

- Simply sitting in the waiting room can help reduce anxiety
- If overwhelming or unresolving panic attack, consult MO/NP who may recommend stat dose of a benzodiazepine
- Reassess medications and their effect on anxiety
- Patient education:²
 - teach and practice breathing exercises
 - reassure that their disorder has been recognised and that help is available
 - anxiety is a normal arousal response to enable a person to focus and act quickly to a threat
 - anxiety in the face of no rational threat can escalate to a pronounced disabling anxiety state; a panic attack
 - treatments take time and may include medications ie antidepressants
 - lifestyle modification:
 - diet and nutrition
 - good sleep patterns
 - regular exercise
 - avoid caffeine, tobacco, alcohol, illicit drug use and overworking
 - self-monitoring and recording of symptoms if they reoccur:
 - where and when do the symptoms happen
 - how do they respond eg escape, avoid, medications, substances
 - return if panic attacks persist
- For recurrent panic attacks refer to mental health services for psychological interventions eg cognitive behaviour therapy

5. Follow up

- Review the patient the next day
- According to MO/NP
- If referral has been made to Mental Health Team see response time and action under [Mental health emergency, p. 336](#)

6. Referral/consultation

- MO/NP or psychologist
- If complex or recurrent then psychiatrist and mental health services
- Mental Health, Alcohol and Other Drugs (MHAODS) for problem alcohol or drug use
- Social worker if the patient requires counselling or support navigating services

- Consider child health services or Child and Youth Mental Health Services if concerned about child in care of patient. See [Child protection](#), p. 551

Alcohol withdrawal

HMP Alcohol withdrawal - adult

Delirium tremens, Wernicke encephalopathy

Recommend^{1,2}

- Alcohol withdrawal delirium (delirium tremens) is a medical emergency
- Benzodiazepines are indicated for delirium tremens not antiepileptics

Background^{1,2}

- Onset occurs 2–5 days after stopping last alcoholic drink
- Progression from mild to moderate to severe withdrawal can occur quickly without treatment
- For alcohol cessation resources, see the *Chronic conditions manual* <https://www.health.qld.gov.au/rccsu/clinical-manuals/chronic-conditions-manual-ccm>

1. May present with

Mild to moderate withdrawal^{1,3}

- Tremor
- ↑ HR and BP
- ↑ T
- Anxiety, agitation, restlessness
- Insomnia
- Nausea and vomiting
- Sweating
- Headache
- Palpitations

Severe withdrawal (progressing to delirium tremens)^{1,2}

- Altered mental status eg confusion and disorientation or restlessness
- Heightened response to stimuli
- Severe hyperactivity, tremor and agitation
- Hallucinations, paranoid and delusional thoughts³
- Seizures
- Sympathetic overdrive eg fluctuation in BP or HR, disturbance of fluid balance and electrolytes, raised temperature
- Cardiovascular collapse

2. Immediate management

- Contact MO/NP for patients with signs of severe withdrawal (delirium tremens) for urgent evacuation/hospitalisation⁴
- Rapid assessment of past and recent alcohol intake, withdrawals, delirium, seizures and medical

conditions. Observe outstretched hands^{1,2}

- If confused or withdrawn, strange, aggressive or acutely disturbed behaviour, see [Mental health emergency, p. 336](#)

3. Clinical assessment^{1,2}

- If in a hyperstimulated state, assess in a quiet room with low light, in the company of a familiar person, friend or relative if possible
- If patient is frightened, reassure and avoid confrontation
- Get history:
 - from family members if patient unable to give a history
 - medications, including non-prescription and illicit drugs
 - alcohol intake:
 - amount, type and duration
 - other alcoholic compounds ie methanol, ethylene glycol, methylated spirits
- Do vital signs +
 - [GCS, p. 562](#)
 - BGL + SpO₂ to exclude glycaemia or hypoxia as cause of behaviour
- Assess for thiamine deficiency (Wernicke encephalopathy):
 - confusion and global memory impairment
 - slurred speech, stumbling, falling
 - involuntary eye movements
- **Wernicke encephalopathy is considered an emergency**
- Assess using the **Alcohol withdrawal scale (AWS)**

Alcohol withdrawal scale (AWS) ¹			
Perspiration	<ol style="list-style-type: none"> 0. Nil 1. Moist skin 2. Beads on face and body 3. Profuse, whole body wet 	Temperature	<ol style="list-style-type: none"> 0. < 37 1. 37.1–37.5 2. 37.6–38 3. 38.1–38.5 4. > 38.5
Tremor	<ol style="list-style-type: none"> 0. No tremor 1. Tremor can be felt in fingers 2. Visible tremor but mild 3. Moderate tremor, arms out 4. Severe, arms not extended 	Hallucinations	<ol style="list-style-type: none"> 0. Lucid 1. Infrequent, aware 2. Brief, persuadable 3. Frequent, distressed 4. No meaningful reality
Anxiety	<ol style="list-style-type: none"> 0. Calm 1. Uneasy 2. Apprehensive 3. Fearful, slow to calm 4. Unable to calm/panic 	Orientation	<ol style="list-style-type: none"> 0. Fully oriented 1. Unsure of time 2. Unsure time, place 3. Unsure time, place, person 4. Disorientated
Agitation	<ol style="list-style-type: none"> 0. Able to rest 1. Unsettled, fidgety 2. Restless, tossing, turning 3. Excitable, pacing 4. Constant movement 	Scoring Key < 5 = mild 5–14 = moderate > 14 = severe	

4. Management

- The immediate aim is to modify the withdrawal and increase the safety of the patient over the next 3–4 days
- Discuss inpatient, outpatient or evacuation options with MO/NP
- Initiate diazepam early in the course of alcohol withdrawal to prevent progression to more severe withdrawal without over-sedation²
- **Give all patients prophylactic thiamine** for Wernicke encephalopathy^{1,2}

ALERT give thiamine before glucose in any form

Glucose may deplete thiamine stores causing Wernicke encephalopathy

- **Mild withdrawal AWS < 5:**¹
 - supportive care
 - maintain hydration, antiemetics, paracetamol for headache, loperamide for diarrhoea
 - sedation with diazepam if necessary as per drug box
 - 4 hourly observations
- **Moderate withdrawal AWS 5–14:**¹
 - maintain hydration
 - sedation with diazepam as per drug box
 - 1 hourly observations
 - continue to **monitor AWS** prior to administering diazepam
 - if not settling after 80 mg diazepam, MO/NP may consider olanzapine 5–10 mg
- **Severe withdrawal AWS > 14 or delirium tremens requires hospitalisation:**¹
 - insert IVC and rehydrate with IV sodium chloride 0.9%
 - urgently contact MO/NP and arrange evacuation
 - diazepam every 2 hours as per drug box (specialist may order midazolam infusion)
 - if not settling after 80 mg diazepam, consult MO/NP
 - continue to **monitor AWS** prior to administering diazepam
- MO/NP will order ongoing diazepam and thiamine regimen for above¹
- Offer antiemetic. See [Nausea and vomiting, p. 40](#)
- Attend to any underlying chronic conditions or infection
- **If being treated as an outpatient, the MO/NP may order:**^{1,3}
 - supply of **daily diazepam regimen:**¹
 - **day 1** diazepam 10 mg 6 hourly
 - **day 2–3** diazepam 5–10 mg 8 hourly
 - **day 4** diazepam 5 mg morning and night
- Other outpatient considerations:
 - a reliable adult to regularly monitor progress
 - a safe, alcohol-free environment
 - withholding medications if alcohol use is resumed
 - a clear plan in case of deterioration or emergency
 - child protection for children of parents or carers who are withdrawing. See [Child protection, p. 551](#)
 - domestic and family violence and safe transport needs

S4	Diazepam			Extended authority ATSIHP/IHW/IPAP/RIPRN
ATSIHP, IHW, IPAP and RN must consult MO/NP				
RIPRN may proceed to administer 1st dose only (max. 10 mg) , then must consult MO/NP				
Form	Strength	Route	Dose	Duration
Tablet	2 mg 5 mg	Oral	Adult Mild AWS < 5 5–10 mg	stat Then every 6–8 hours for first 48 hours
			Adult Moderate AWS 5–14 10–20 mg	stat Then every 2 hours until good symptom control (max. 80 mg)
			Adult Severe AWS > 14 or delirium tremens 20 mg	stat Then 1 hourly for 4–6 hours (max. 80 mg)
Offer CMI: May cause drowsiness, oversedation, light-headedness, hypersalivation, ataxia, slurred speech or effects on vision				
Note: Monitor respiratory rate closely. Halve the usual adult dose in the elderly ± debilitated or discuss with MO/NP				
Contraindication: Myasthenia gravis, severe hepatic impairment				
Management of associated emergency: Consult MO/NP. See Anaphylaxis, p. 82				1,4

Unscheduled	Thiamine			
ATSIHP, IHW, IPAP, RIPRN and RN may proceed				
Form	Strength	Route	Dose	Duration
Injection	300 mg/3 mL	IV Dilute in 10–20 mL of sodium chloride 0.9% or IM undiluted	Adult 300 mg	stat If IV inject slowly over 10 minutes
Offer CMI: Given to prevent Wernicke encephalopathy				
Note: Give IV/IM thiamine before or with glucose to patients at risk of alcohol-related thiamine deficiency; administration of glucose without thiamine may precipitate Wernicke encephalopathy				
Management of associated emergency: Contact MO/NP. See Anaphylaxis, p. 82				1,2,5

5. Follow up

- On the first morning, assess the patient for:
 - early withdrawal symptoms. See **Alcohol withdrawal scale (AWS)**
 - intoxication or alcohol consumption in the past 8 hours. If any, cease treatment
- MO/NP/drug and alcohol RN should see the patient daily for the first 3–4 days. Then continue daily or second daily contact until withdrawal is completed

6. Referral/consultation¹

- Mental Health, Alcohol and Other Drugs for ongoing follow up, counselling and case management
- Consider child health services or Child and Youth Mental Health Services if concerned about welfare of children in care of patient. See [Child protection, p. 51](#)

Page intentionally left blank

Obstetrics and neonatal

Antenatal

Termination of pregnancy (ToP)

Recommend¹

- Facilitate women in rural and remote areas to access ToP services as would occur for any specialist procedure. Ensure referral and transfer systems are in place with other service level facilities
- If you have a conscientious objection to involvement with decision making around ToP you must ensure appropriate and timely transfer of care to another health professional
- For Qld legal issues, consent + other information regarding ToP see Qld Clinical Guideline *Termination of pregnancy* <https://www.health.qld.gov.au/qcg/publications#maternity>

1. May present with

- Missed period(s)
- +ve pregnancy test
- Request for abortion/ToP

2. Immediate management Not applicable

3. Clinical assessment¹

- Ensure a confidential and non-judgemental approach
- Do:
 - urine pregnancy test to confirm
 - vital signs
 - ask about usual menstrual cycle - regular/irregular, date of last menstrual period (LMP)
 - calculate gestational age:
 - count weeks and days from first day of LMP *eg 4 weeks + 3 days*
- Arrange dating USS promptly:
 - can be done on-site by midwife/MO if have specific training
 - intrauterine pregnancy to be confirmed (ectopic pregnancy contraindicated in medical ToP)¹
- Do:
 - [STI/BBV tests, p. 448](#)
 - ‘1st visit’ antenatal bloods. See [Antenatal care, p. 364](#)
- Ask about this pregnancy - expectations, experiences
- Consider social and emotional issues/concerns eg:
 - sexual assault, mental health, safety and privacy issues
 - screen for domestic and family violence - use local assessment tools
- Current (if any) contraception and discuss future [Contraception options, p. 438](#)
- Get medical, gynaecological, obstetric and sexual health history:
 - see [Antenatal care, p. 364](#) and [STI/BBV assessment, p. 445](#) for prompts

4. Management¹

If woman is considering a ToP or is unsure¹

- **Time sensitive decision** - depending on how far along pregnancy is and where woman lives, may need to refer quickly
- Provide accurate and unbiased information. For advice/help with decision making:
 - Marie Stopes <https://www.mariestopes.org.au/> ☎ 1300 207 382 (national)
 - Children by Choice <https://www.childrenbychoice.org.au/> ☎ 1800 177 725 (Qld)
 - **note:** Children by Choice also list public and private providers of ToP + costs
- **Options** - medical ToP (MToP), surgical ToP (SToP) or a combination:¹
 - MToP may be done in some areas as an outpatient if gestation ≤ 9 weeks (≤ 63 days)
 - SToP can be done up to 12 weeks gestation, sometimes later
- Choice is influenced by woman's preference, age, gestation, local clinician expertise/service capabilities and availability of pharmacological agents

If woman decides to have a ToP

- Assist woman to access ToP services as early as possible
- **Check local procedures and policies** on who to contact to coordinate this eg dedicated women's or sexual health RN/NP
- If woman needs to travel away from her community:
 - assist access to patient travel subsidy scheme (Qld)
 - ensure emotional support is provided

If woman decides to continue with the pregnancy

- Refer to midwife/antenatal clinic

5. Follow up

- Advise woman to have follow up within 1–2 days:
 - further support woman in her decision making, or as appropriate to individual circumstances
 - check pathology results and treat as appropriate

6. Referral/consultation

- Offer mental health referral as needed

Antenatal care

Recommend

- Use Qld *Pregnancy health record* (PHR) <https://qheps.health.qld.gov.au/car/clinical-pathways/maternity> or local clinical pathway
- Woman centred care - based on her needs, preferences + empowerment in decision making¹
- See Qld Clinical Guidelines if risks/complications eg ↑ BMI, diabetes, ↑ BP, syphilis, RHD <https://www.health.qld.gov.au/qcg/publications#maternity>
- Where possible use PoCT or do urine PCR. Dipstick testing has high false +ve for proteinuria²

Background

- In Qld several babies have died from congenital syphilis, which is preventable with adequate testing + management³
- See *National midwifery guidelines for consultation and referral* <https://www.health.qld.gov.au/qcg>

1. May present with

- Pregnant

2. Immediate management Not applicable

3. Clinical assessment¹

- Confirm pregnancy by urine/blood test (β-hCG)
- Ask the woman how she is feeling about the pregnancy, consider:
 - planned/unplanned/wishes to proceed with pregnancy²
- Plan care with woman:
 - refer for first visit with midwife/MO, however still take 1st visit bloods/pathology today
 - consider/plan transfer at 36–38 weeks to await the birth, including social, cultural, financial, clinical issues + local policy. Aim to optimise outcomes + ↓ impact on the family

First visit² (long visit)

- Ideally at < 10 weeks pregnant:
 - for later presentations, do all first visit care + **Additional tests/activities** not yet done

Estimate date of birth/gestational age²

- Ask about usual menstrual cycle
- Calculate due date from first day of last normal menstrual period - if known
- Offer dating USS at **8–13+6 weeks** (most accurate 8–10 weeks).^{2,4} Can be done locally by trained midwife/MO or arrange appointment/transfer
- Offer to book First trimester screening/**Nuchal screening**, p. 365 done between 11–13+6 weeks (can get both tests in single USS)

Get past history²

- **Obstetric** - previous pregnancies, gestation, place of birth, labour - duration + induced/spontaneous, type of birth, weight of baby, infant feeding, any complications eg APH, preeclampsia, diabetes, baby with early onset GBS disease, preterm labour, perineal trauma, PPH
- **Gynaecological** - last CST, fertility problems, STIs, syphilis, surgery
- **Medical/surgical** - hypertension, RHD, blood conditions, thyroid problems, asthma, mental health, diabetes, oral health

- **Medications** - review for safety in pregnancy
- **Social/family** - support available, financial issues, social environment
- **Smoking, alcohol, other drugs** - use screening tools and initiate brief intervention eg as per PHR⁵
- **Physical activity, nutrition**
- **Zika risk** - women or partner travelled to Zika area while pregnant or 1 month prior to conception.⁶ See <https://www1.health.gov.au/internet/main/publishing.nsf/Content/ohp-zikavirus>

Physical examination¹

- BMI - if > 30 ↑ risk of complications. See Qld Clinical Guideline *Obesity in pregnancy*
- Vital signs. If BP elevated see [Hypertension in pregnancy, p. 383](#)
- Auscultate heart (if skilled) for murmurs in areas with high prevalence of RHD²
- If ≥ 12 weeks assess - fundal height + FHR

Take pathology²

- **Bloods:**
 - FBC, ferritin,⁷ blood group and antibodies, rubella antibodies, BGL
 - hep B, hep C
 - syphilis serology, HIV
 - HbA_{1c}, iron studies - for Aboriginal and Torres Strait Islander/other high risk women
 - **consider:**⁸
 - vitamin D - if risk factors eg darker skin, increasing BMI, winter
 - LFT, UE - if BMI > 30
 - TFT - if age > 30 or ≥ 2 previous pregnancies or risk factors for thyroid dysfunction²
 - cytomegalovirus (CMV) - if frequent contact with large numbers of young children eg teachers, childcare workers
- **Urine:**
 - dipstick and MSU for MCS
 - PCR for baseline proteinuria²
 - chlamydia PCR. If Aboriginal and Torres Strait Islander or ↑ risk for STIs, also do gonorrhoea PCR (+ trichomonas PCR if symptoms). See [STI/BBV tests, p. 448](#)
- **Offer:**
 - CST if due - use cyto-broom, not endocervical brush⁹
 - HVS for [BV, p. 457](#) if prior preterm birth²

Discuss chromosomal anomalies tests regardless of woman's age

- Support rural and remote women to access tests²
- **First trimester screening/Nuchal screening USS + bloods** for free Beta-hCG + Papp-A:
 - take bloods after 10 completed weeks (preferably 3–5 days prior to USS). Include EDD and current weight on pathology form
 - USS between 11–13+6 weeks
- **± NIPT blood test** if > 10 weeks gestation (optional/if available, not covered by Medicare)⁵
- **± diagnostic tests** as appropriate:
 - chorionic villus sampling < 14 weeks/amniocentesis ≥ 16 weeks

Do risk assessments^{2,5}

- VTE prophylaxis eg as per PHR
- EPDS <https://www.blackdoginstitute.org.au/wp-content/uploads/2020/04/edinburgh-postnatal-depression-scale.pdf>
- SAFE Start https://qheps.health.qld.gov.au/__data/assets/pdf_file/0031/417748/mr63ak.pdf (Qld Health intranet)

- **Also assess risk factors** (as per Qld Clinical Guidelines) for:
 - preeclampsia - advise if moderate/high risk, it may be prevented with low-dose aspirin started preferably < 16 weeks + calcium supplement if dietary intake low¹⁰
 - [Diabetes in pregnancy, p. 378](#) may need OGTT in first trimester
 - preterm birth
 - obesity in pregnancy

Supplements/vaccines/advice²

- **Supplements** - if available, give pregnancy multivitamin eg containing folic acid, iodine and iron (note, iron not routinely recommended in pregnancy):
 - folic acid at least 400 microg daily - 1 month before conception until 12 weeks²
 - iodine 150 microg daily - if pre-existing thyroid condition seek MO/NP advice first²
 - vitamin D - if levels < 50 nmol/L²
 - if low in omega-3 - daily omega-3 long-chain polyunsaturated fatty acids²
- **Vaccines:**¹¹
 - influenza + COVID-19 - given any time during pregnancy¹²
 - pertussis (dTpa) given 20–32 weeks
- **Discuss measures to avoid** cytomegalovirus infection or toxoplasmosis (offer screening if at risk)²
- Offer [General pregnancy advice, p. 368](#) eg pregnancy symptoms, nutrition, physical activity, dental visits,² risks of syphilis in pregnancy

Ongoing antenatal care

- Use table below to guide visits, aiming for around 10 visits if 1st pregnancy and 7 in next pregnancies. If complications, extra visits may be needed

At every visit²

- Ask about wellbeing, any concerns/issues²
- BP + vital signs
- If > 12 weeks - fundal height + FHR
- Urinalysis - MSU for MCS if indicated. Also see [UTI in pregnancy, p. 375](#):
 - **note:** if 1 + of protein, confirm by urine PCR
- Weight - offer to be weighed, encourage self-monitoring of weight gain/diet/exercise
- Discuss test results and reassess plan/if referral needed
- Tobacco/drug/alcohol screening as appropriate^{5,15}
- Check and do [Additional tests/activities, p. 367](#) depending on gestation
- Check for symptoms of [Syphilis, p. 468](#) and reassess if [Increased/high risk of syphilis, p. 368](#)
- Offer [General pregnancy advice, p. 368](#) about healthy diet, physical activity etc
- If Rh D –ve blood group - Anti-D, why/when needed as per [Rh D immunoglobulin, p. 369](#)
- **20 weeks onwards:**
 - check for signs of preeclampsia - proteinuria/BP
 - **discuss baby's movements:**
 - importance of getting to know baby's pattern of movements¹⁵
 - usually start feeling between 16–24 weeks
 - if pattern changes it may be a sign baby is unwell, if concerned, contact midwife/clinic immediately. **Do not wait till next day**

Additional tests/activities²18–20 weeks^{2,5}

- USS for morphology. Note BMI on request form (if BMI \geq 30, consider morphology at 22 weeks)

20–27 weeks

- Syphilis serology - if [High risk of syphilis, p. 368](#) around 20 weeks (take between 16–24 weeks)³

28 weeks

Take bloods/pathology:

- OGTT. If post bariatric surgery may not be suitable, see [Diabetes in pregnancy, p. 378](#)
- FBC, ferritin⁷
- Rh D antibody screen - before giving Anti-D
- Syphilis serology (take between 26–28 weeks)
- If Aboriginal and Torres Strait Islander or ↑ risk for STIs, also do **urine PCR** for:
 - gonorrhoea, chlamydia

Discuss:

- Sleeping on side from now till birth - may reduce risk of stillbirth¹⁵
- Repeat SAFE start and EPDS^{2,5}

Give:^{2,5}

- Anti-D if Rh D –ve blood group. See [Rh D immunoglobulin, p. 369](#) (take bloods first as above)
- Iron supplements if needed - based on Hb results. Advise weekly supplement is as effective as daily supplement in preventing iron-deficiency anaemia, with fewer side effects¹

29–34 weeks²

- **32 weeks** - repeat USS if placenta over cervical os or low lying on morphology USS
- **34 weeks** - 2nd dose of anti-D if Rh D –ve. [Rh D immunoglobulin, p. 369](#)
- **34–36 weeks** - syphilis serology if [High risk of syphilis, p. 368](#)
- Check dTpa given + recommend for close contacts if last dose $>$ 10 years ago, at least 2 weeks before contact with baby¹¹
- Discuss - signs of early labour and when to seek advice; labour and birth planning, what to expect, breastfeeding.^{2,5} See [General pregnancy advice, p. 368](#)

35–38 weeks²**36 weeks - take pathology**

- FBC + ferritin to check response to iron supplement if given⁷
- Syphilis serology (regardless of risk)
- If Aboriginal and Torres Strait Islander or ↑ risk for STIs, also take:
 - HIV and urine PCR for gonorrhoea, chlamydia (+ trichomonas if symptoms). See [STI/BBV tests, p. 448](#)

Check:

- Fetal presentation, do palpation - if unsure, confirm with USS in collaboration with MO. If breech, discuss options in collaboration with MO eg external cephalic version
- VTE risk⁵
- Risk factors for early onset [Group B Strep, p. 395](#)
- BMI. If ↑ also see Qld Clinical Guideline *Obesity in pregnancy*

Offer advice/discuss:

- Care of new baby, reducing risk of SIDS, newborn screening tests, vitamin K and hep B, labour, birth, support in postnatal period²
- Transfer for birth, ensure PHR goes with woman + copy for medical record

Increased/high risk of syphilis³**Increased risk**

- Woman or partner identify as Aboriginal and Torres Strait Islander
- Adolescent
- STI in current pregnancy or in last 12 months
- Ongoing sexual links in areas of high prevalence of syphilis (woman or partner)
- Other risk factors. See [STI/BBV assessment, p. 445](#)

High risk

- Sexual contact of someone with syphilis
- Woman or partner identify as Aboriginal and Torres Strait Islander AND live in an outbreak area
- Substance use eg ice
- Woman's partner is a man who has sex with men
- Late, limited or no antenatal care
- Engages in high risk sexual activity

Also see Qld Clinical Guideline *Syphilis in pregnancy* <https://www.health.qld.gov.au/qcg/publications#maternity>

General pregnancy advice¹

Nutrition and physical activity	<ul style="list-style-type: none"> • See Australian dietary guidelines for healthy eating https://www.health.gov.au/resources/publications/the-australian-dietary-guidelines • Foods to avoid eg alcohol, sources of listeria and fish high in mercury • Usual physical activity is beneficial and safe
Medicines	<ul style="list-style-type: none"> • Limit use to where the benefits outweigh the risks • The effectiveness and safety of herbal preparations varies according to the herbal preparation and the condition being treated • Supplements of vitamin A, C and E are of no benefit and may cause harm
Common pregnancy symptoms	<ul style="list-style-type: none"> • See https://www.thewomens.org.au/health-information/pregnancy-and-birth/a-healthy-pregnancy/common-concerns-in-early-pregnancy/
Breastfeeding (BF)	<ul style="list-style-type: none"> • See PHR and https://www.breastfeeding.asn.au/ <ul style="list-style-type: none"> – skin to skin contact at birth, initiation of BF, demand feeding, safe formula feeding if chosen – positioning + attachment, signs baby is getting enough milk – why teats/dummies discouraged early on – benefits of exclusive BF for around 6 months
Travel	<ul style="list-style-type: none"> • Correct use of 3 point seatbelts eg above and below the bump, not over it • Long-distance air travel can ↑ risk of venous thrombosis¹ • Discuss travel vaccinations with midwife/MO
Oral health	<ul style="list-style-type: none"> • Advise to have check-up. Treatment is safe during pregnancy
Sexual intercourse	<ul style="list-style-type: none"> • Safe during pregnancy

4. Management

- Discuss with MO/NP/obstetrician risks/concerns
- Send booking in referral as per local policy

5. Follow up

- As above

6. Referral/consultation

- Consider referral(s) eg diabetes educator, dietitian, mental health clinician²

HMP Rh D immunoglobulin

Recommend¹

- Rh D immunoglobulin (anti-D) is recommended for pregnant women with Rh D –ve blood group

Background¹

- If the mother is Rh D –ve blood group and the baby's blood group is +ve, the baby's blood may stimulate an immune response in the mother's blood (sensitisation). This can result in maternal antibodies crossing the placenta causing haemolytic disease of the fetus and the newborn (HDFN)
- See National Blood Authority. *Prophylactic use of Rh D immunoglobulin in pregnancy care 2021* <https://www.blood.gov.au/anti-d-o>

1. May present with¹

- Rh D negative blood group at 28 or 34 weeks, or with a sensitising event
- + does not have 'preformed' anti-D antibodies

2. Immediate management Not applicable

3. Clinical assessment^{1,2}

- Use table below to identify **Sensitising events**

Sensitising events		
1st trimester 0–12 weeks	2nd and 3rd trimester after 12+6 weeks	Birth
<ul style="list-style-type: none"> • Miscarriage (not threatened miscarriage < 12 weeks) • ToP - medical or surgical • Ectopic pregnancy • Hydatidiform mole • Chorionic villi sampling 	<ul style="list-style-type: none"> • Antepartum haemorrhage - revealed or concealed (each occasion) • Abdominal trauma • Miscarriage, ToP • Amniocentesis/other invasive intervention • External cephalic version • Any other suspected intrauterine bleeding 	<ul style="list-style-type: none"> • Rh D positive baby

4. Management^{1,2}

Routine Rh D immunoglobulin at 28 and 34 weeks

- Re-take bloods for antibody screen PRIOR to giving at 28 weeks (no need to wait for results). If results positive, consult MO/NP
- If 28 week dose missed, give as soon as recognised, then give the 2nd dose 6 weeks later

Rh D immunoglobulin for a sensitising event

- Give as soon as able (within 72 hours). If delayed, give up to 10 days after the event (lower efficiency)
- **If > 20 weeks** of pregnancy, take bloods first (no need to wait for results):
 - group and antibodies, and Kleihauer - to assess the magnitude of fetomaternal haemorrhage (FMH). **If birth**, also collect cord blood for group and Coombs' test
 - if large FMH, follow laboratory/obstetric advice for additional dose(s). Give within 72 hours
- If ongoing uterine bleeding, repeat dose(s) may be needed at 6 weekly intervals¹
- Still give 28 and 34 week Rh D immunoglobulin if extra dose(s) are given for sensitising event(s)

S ₄	Rh D Immunoglobulin			Extended authority MID
RIPRN and RN must consult MO/NP				
MID may proceed				
Form	Strength	Route	Dose	Duration
Injection	250 units	IM	Antenatal - 28 and 34 weeks 625 units	stat
	625 units		Sensitising event in the 1st trimester 250 units	Inject deep and slowly If more than 5 mL is required give in divided doses in different sites
			Sensitising event > the 1st trimester + birth 625 units	
Offer CMI: See <i>Red blood cell alloimmunisation</i> https://rancog.edu.au/womens-health/patient-information-guides/patient-information-pamphlets				
Note: Bring to room temperature. Give via deep IM injection - if high BMI give in deltoid				
Contraindication: A baby, an Rh D positive woman				
Management of associated emergency: Consult MO/NP. See Anaphylaxis, p. 82				

1-4

5. Follow up²

- If antibodies are already present in antenatal bloods, consult MO/NP as ongoing monitoring may be required

6. Referral/consultation

- As above

Pregnancy complications

HMP Ectopic pregnancy

Recommend^{1,2}

- Consider in all females of reproductive age with abdominal pain ± vaginal bleeding, even if the woman does not think she is pregnant. Always do a pregnancy test
- The woman's psychological needs should be acknowledged + considered at all times

Background^{1,2}

- Rupture of an ectopic pregnancy can result in life-threatening haemorrhage
- Ectopic pregnancy occurs outside of the uterus, usually in the fallopian tube
- Symptoms typically appear 6–8 weeks after the LNMP, but may occur later eg if somewhere other than the fallopian tube. Diagnosis is based on a combination of transvaginal USS + serum β -hCG
- Also see Qld Clinical Guideline *Early pregnancy loss* <https://www.health.qld.gov.au/qcg/publications#maternity>

1. May present with^{1,2}

- Woman may not know she is pregnant
- Abdominal pain ± irregular bleeding, spotting
- If ruptured, may haemorrhage in abdominal cavity:
 - shoulder tip or diaphragmatic pain
 - signs of shock:³
 - ↑ HR, ↓ BP, ↑ RR
 - restlessness
 - sweating
 - cool, clammy skin
 - ↓ urine output
- May mimic UTI, PID, miscarriage, appendicitis⁴

2. Immediate management¹

- **If signs of shock:**
 - call for help + urgently contact MO/NP for advice/arrange evacuation
 - insert IVC x 2 eg 16 G
 - give bolus IV sodium chloride 0.9% or Hartmann's 10–20 mL/kg:
 - ongoing IV fluids as per MO/NP
 - insert IDC
 - take blood for urgent FBC, group and hold, β -hCG
 - if ruptured ectopic pregnancy, woman will require urgent surgery²
 - get rapid history

3. Clinical assessment^{1,2,5}

- **Ask about:**
 - bleeding/spotting - amount, when did it start, any clots
 - pain or cramping - where, how severe, diffuse or to one side
 - shoulder tip pain
 - feeling faint when standing

- recent abdominal trauma
- date of first day of LNMP
- dysuria/frequency of urine
- other symptoms/concerns
- **Antenatal history** if pregnancy known:
 - has pregnancy location been confirmed by transvaginal USS - is the pregnancy in the uterus
 - estimate gestation based on dating scan or LNMP
 - check blood group and antibody status
- **Obstetric history** - prior pregnancies, miscarriages, previous ectopic pregnancy, tubal surgery, infertility, contraceptives, intrauterine device use
- **Past history:**
 - bleeding disorders, diabetes, thyroid disease, polycystic ovary syndrome, celiac disease
 - abnormalities of reproductive tract
 - STIs, when, treatment, last tested
 - PID - when, treatment
- **Do:**
 - vital signs
 - pregnancy test even if the woman does not think she is pregnant
 - check loss on pad as applicable:
 - amount, rate of loss, colour of blood - bright, dark, presence of clots, size
 - urinalysis + MSU if indicated
 - gently palpate abdomen - any tenderness, rigidity, guarding, distension
 - avoid bimanual examination - bleeding risk⁴
- Take blood for FBC, group and hold, β -hCG
- Consider [STI/BBV tests, p. 448](#)

4. Management¹

- If location of pregnancy is not known treat as ectopic pregnancy until proven otherwise
- Evacuation for USS confirmation of location of pregnancy
- Consult MO/NP urgently
- Insert IVC x 2 eg 16 G
- Keep nil by mouth
- Offer analgesia. See [Acute pain, p. 32](#)
- If Rh D –ve and managed locally, may need [Anti D, p. 369](#)

5. Follow up

- Consider grief counselling if appropriate

6. Referral/consultation

- As above

HMP Vaginal bleeding in early pregnancy

Up to 20 weeks gestation

Recommend¹

- If pregnancy location unknown ie woman has not had an USS to confirm pregnancy is in the uterus, always suspect ectopic pregnancy regardless of amount of bleeding/pain
- The woman's psychological needs should be acknowledged and considered at all times
- Also see Qld Clinical Guideline *Early pregnancy loss* <https://www.health.qld.gov.au/qcg/publications#maternity>

1. May present with^{1,2}

- Pregnancy \leq 20 weeks gestation with:
 - vaginal spotting or bleeding
 - abdominal \pm shoulder tip pain
 - backache
 - passage of products of conception (POC)
 - **note:** if bleeding $>$ 20 weeks, see [APH, p. 390](#)
- If bleeding very heavy, may have signs of shock:³
 - \uparrow HR, \downarrow BP, \uparrow RR
 - restlessness
 - sweating
 - cool, clammy skin
 - \downarrow urine output

2. Immediate management^{1,2}

If pregnancy location unknown ie woman has not had an USS to confirm pregnancy is in the uterus, **always** suspect ectopic pregnancy regardless of amount of bleeding/pain.

See [Ectopic pregnancy, p. 371](#)

- **If signs of shock:**¹
 - call for help
 - consult MO/NP urgently
 - insert IVC x 2 eg 16 G
 - give bolus IV sodium chloride 0.9% or Hartmann's 10–20 mL/kg:
 - ongoing IV fluids as per MO/NP
 - if skilled, perform urgent speculum examination to remove POC from cervix/vagina - this may stop bleeding and restore BP
 - insert IDC
 - take blood for urgent FBC, group and hold
- If POC collected or passed spontaneously send for histopathology¹
- For persistent bleeding **where ectopic pregnancy has been excluded** MO/NP may consider/order:¹
 - IV/IM ergometrine 250 microg \pm PR misoprostol 800–1000 microg:
 - see [Primary PPH, p. 417](#) for doses
 - \pm activation of massive transfusion protocol

3. Clinical assessment^{1,2}

- **Ask about:**
 - bleeding/spotting - amount, when did it start, any clots
 - lower abdominal pain or cramping - where, how severe
 - shoulder tip pain - may indicate intra-abdominal bleeding
 - feeling faint when standing
 - recent abdominal trauma
 - date of first day of LNMP
 - other symptoms/concerns
- **Antenatal history:**
 - check records
 - has pregnancy location been confirmed:
 - is fetus in the uterus confirmed by transvaginal USS
 - if not confirmed always consider [Ectopic pregnancy, p. 371](#) until proven otherwise
 - estimate gestation based on dating scan or LNMP
 - confirm placenta site, if possible, to exclude placenta praevia
 - check blood group and antibody status
- **Obstetric history:**
 - prior pregnancies, miscarriages, previous ectopic pregnancy, tubal surgery, infertility, contraceptives, intrauterine device use
 - bleeding disorders
 - medicines and allergies
 - chronic diseases - diabetes, thyroid disease, polycystic ovary syndrome, coeliac disease, RHD
 - any abnormalities of the reproductive tract
 - STIs/PID - when, treatment, last tested
- **Do:**¹
 - vital signs
 - confirm pregnancy by urgent serum quantitative β -hCG:
 - do urine pregnancy test if serum result is likely to be delayed
 - check loss on pad - amount, rate of loss, colour of blood - bright, dark, presence of clots, size
 - urinalysis + MSU if indicated
 - gently palpate abdomen - any tenderness, rigidity, guarding, distension

4. Management¹

- For women with unconfirmed/uncertain pregnancy location (not known if in the uterus) consider [Ectopic pregnancy, p. 371](#) until proven otherwise
- Keep nil by mouth
- Consult MO/NP who may advise:
 - bloods - FBC + blood group, serial β -hCG levels
 - evacuation/hospitalisation for USS, further investigations/treatment
 - IV antibiotics - if fever or offensive cervical discharge
 - [STI/BBV tests, p. 448](#)
- MO/NP may advise speculum examination if clinician skilled, check for:
 - blood coming through os
 - os closed or open/POC protruding - gently remove with sponge forceps
 - offensive cervical discharge

- If Rh D –ve blood group with no pre-formed anti-D antibodies and > 12 weeks gestation,⁴ offer [Rh D immunoglobulin, p. 369](#)
- Offer analgesia. See [Acute pain, p. 32](#)

5. Follow up

- Consider counselling for parents who have experienced pregnancy loss
- If not evacuated/hospitalised advise patient to be reviewed according to MO/NP instructions
- If applicable follow up STI test results and treat

6. Referral/consultation

- Consult MO/NP on all occasions of vaginal bleeding in pregnancy

HMP Urinary tract infection (UTI) in pregnancy

Recommend

- Consider [Ectopic pregnancy, p. 371](#) + [PID, p. 462](#) if presenting with low abdominal pain¹
- MSU culture is the standard for diagnosing asymptomatic bacteriuria (ASB)
- In rural + remote areas, dipstick tests for nitrites may be used to exclude ASB, with +ve results confirmed by urine culture
- Appropriate storage of dipsticks is essential for accuracy²

Background

- ASB has been associated with preterm birth + ↑ risk of pyelonephritis¹
- Antibiotics significantly ↓ risk of developing pyelonephritis²

1. May present with³⁻⁷

- Nitrites ± leucocytes on urinalysis

Asymptomatic bacteriuria (ASB)

- Detected on antenatal screening MSU (no symptoms)

Cystitis - infection of the bladder

- Dysuria, urgency, frequency
- Haematuria
- Lower abdominal pain
- Sometimes mild low back pain

Pyelonephritis - infection of the kidney

- Fever, rigors
- Nausea, vomiting
- Flank pain

2. Immediate management

- Do vital signs
- Screen for [Sepsis, p. 64](#)

3. Clinical assessment^{1,3,5}

- **Ask about:**
 - urinary symptoms - dysuria, frequency, urgency, haematuria
 - pain - abdominal, suprapubic
 - vaginal discharge
 - fever, rigors, flank tenderness
 - nausea, vomiting, intake/appetite
 - if > 20 weeks ask about fetal movements - normal, decreased or any concerns
 - other symptoms/concerns
- **Check:**
 - antenatal history
 - calculate gestation based on dating scan or LNMP
 - previous UTIs - when, treatment:
 - check previous urine pathology results to ensure no resistance to antibiotics recommended
 - medical history eg diabetes, anatomical abnormalities with urinary tract
 - STIs - when, treatment, last tested
- **Do:**
 - palpate abdomen. Any:
 - tenderness - loin, groin or suprapubic area. May indicate calculi or upper UTI
 - contractions, tightening
 - if > 12 weeks listen to FHR if skilled - infection can ↑ FHR
 - MSU for MCS prior to giving antibiotics⁶
 - **STI/BBV tests, p. 448** for:
 - gonorrhoea, chlamydia and trichomonas PCR + bacterial vaginosis
 - syphilis serology if not already done, or due

4. Management^{1,2}

- If symptomatic also consider differential diagnoses eg STI, PID
- Consult MO/NP if uncertain
- **If pyelonephritis:**⁶
 - consult MO/NP urgently + arrange evacuation/hospitalisation
 - insert IVC x 2
 - MO/NP will order IV gentamicin + ampicillin
- **If ASB:**
 - treat based on results of urine MCS
 - if dipstick suggests ASB + treatment might be delayed waiting for results:²
 - give antibiotics without waiting
 - treat as per acute cystitis⁶
- **If acute cystitis** - start antibiotics based on symptoms, give:⁶
 - nitrofurantoin - except if near delivery or > 37 weeks **OR**
 - cefalexin
- Offer analgesia. See [Acute pain, p. 32](#)
- Encourage increasing fluid intake + complete bladder emptying to avoid retention

If Group B Strep (GBS) on culture, antibiotic cover in labour is needed even if previously treated. Make a note in antenatal record and advise woman.⁶ See [Group B Strep, p. 395](#)

S ₄	Nitrofurantoin			Extended authority ATSIHP/IHW/IPAP/MID/RIPRN	
ATSIHP, IHW, IPAP and RN must consult MO/NP					
MID and RIPRN may proceed					
Form	Strength	Route	Dose	Duration	
Capsule	50 mg, 100 mg	Oral	100 mg qid	5 days	
Offer CMI: Take with food or milk to reduce nausea + improve absorption. May cause nausea, vomiting, headache, drowsiness or dizziness. Report if develop difficulty breathing, cough, numbness or tingling. May turn urine a brownish colour. Do not use with urinary alkalisers (eg Ural®, Citravescent®) as they reduce the antimicrobial effect					
Contraindication: Renal impairment. Do not give if near delivery or > 37 weeks due to risk of neonatal haemolytic anaemia					
Management of associated emergency: Consult MO/NP. See Anaphylaxis, p. 82					6,8

S ₄	Cefalexin			Extended authority ATSIHP/IHW/IPAP/MID/RIPRN	
ATSIHP, IHW, IPAP and RN must consult MO/NP					
MID and RIPRN may proceed					
Form	Strength	Route	Dose	Duration	
Capsule	250 mg, 500 mg	Oral	500 mg bd	5 days	
Offer CMI: May cause rash, diarrhoea, nausea, vomiting, dizziness, headache or thrush					
Note: If renal impairment seek MO/NP advice					
Contraindication: Severe or immediate allergic reaction to a cephalosporin or a penicillin. Be aware of cross-reactivity between penicillins, cephalosporins and carbapenems					
Management of associated emergency: Consult MO/NP. See Anaphylaxis, p. 82					6,9

S ₄	Amoxicillin + clavulanic acid			Extended authority ATSIHP/IHW/IPAP/MID/RIPRN	
ATSIHP, IHW, IPAP and RN must consult MO/NP					
MID and RIPRN may proceed					
Form	Strength	Route	Dose	Duration	
Tablet	500 mg + 125 mg	Oral	500 mg + 125 mg bd	5 days	
Offer CMI: Take with food. May cause rash, diarrhoea, nausea or thrush. Can cause severe diarrhoea (colitis) due to <i>C. difficile</i>					
Contraindication: Severe or immediate allergic reaction to a penicillin. Be aware of cross-reactivity between penicillins, cephalosporins and carbapenems. Avoid in women with premature rupture of membranes as there may be an increased risk of neonatal necrotising enterocolitis					
Management of associated emergency: Consult MO/NP. See Anaphylaxis, p. 82					6,10

5. Follow up¹⁰

- Check results of MSU + modify antibiotics based on culture and susceptibility testing:
 - amoxicillin + clavulanic acid may be a suitable alternative⁶
- Repeat urine MCS 1–2 weeks after treatment completed. If persistent bacteriuria, treat with a second course of antibiotics

- Following resolution, repeat MSU at antenatal visits to monitor:
 - **note:** dipstick for nitrites is useful to exclude ASB, but is not accurate for diagnosis. Use MSU wherever possible as it is the most accurate²
- If recurrent infections, or at risk of complications eg has diabetes, consider prophylaxis for remainder of pregnancy - discuss with MO/NP⁶
- Follow up STI test results + treat as required

6. Referral/consultation

- As above

Diabetes in pregnancy

Recommend¹

- If pre-existing diabetes:
 - care is provided by a multidisciplinary team before + during pregnancy
 - encourage women to obtain as near as non-diabetic glycaemic control as possible before pregnancy
 - high dose folate (5 mg/day) commencing 1 month pre-pregnancy
 - treat as a complicated pregnancy

Background¹⁻³

- Women with pre-existing diabetes (types 1 + 2) are more prone to complications of pregnancy eg preeclampsia, prematurity + caesarean section
- Principles of management:
 - monitor BGL - aiming for as close to the normal (non-diabetic) range as possible
 - ensure risks for maternal hypoglycaemia are minimised
 - adopting healthy eating pattern + physical activity
- Also see Qld Clinical Guideline *Gestational diabetes mellitus* <https://www.health.qld.gov.au/qcg/publications#maternity>

1. May present with¹

- Pregnant with:
 - pre-existing diabetes - type 1 or 2 diagnosed prior to pregnancy
 - risk factor(s) for gestational diabetes mellitus (GDM)
 - diagnosis of GDM

2. Immediate management Not applicable

3. Clinical assessment¹

- **If pre-existing diabetes and +ve pregnancy test:**
 - get medication history
 - promptly discuss with MO/NP/pharmacist regarding the need for/safety of use of current medicines in pregnancy
 - oral hypoglycaemics may need to be substituted with insulin
 - refer to MO/NP/obstetrician for further assessment and pregnancy care planning
- **For GDM** - see following flowchart
- **If post bariatric surgery** eg gastric banding - OGTT may not be suitable, consult MO/NP

Screening and diagnosis of GDM¹

Assess all pregnant women for risk factors

- Risk factors for GDM**
- BMI > 30 pre-pregnancy or on entry to care
 - Ethnicity - Aboriginal and Torres Strait Islander, Pacific Islander, Maori, Asian, Indian subcontinent, Middle Eastern, Non-white African
 - Previous GDM
 - Previous elevated BGL
 - Maternal age ≥ 40 years
 - Family history DM - 1st degree relative or sister with GDM
 - Previous large for gestational age - birth weight > 4500 g or > 90th percentile
 - Previous perinatal loss
 - Polycystic ovary syndrome
 - Medications - corticosteroids, antipsychotics
 - Multiple pregnancies

- GDM diagnosis**
- **OGTT 1 or more of:**
 - fasting ≥ 5.1
 - 1 hour ≥ 10
 - 2 hour ≥ 8.5
 - **HbA_{1c} (if OGTT not suitable)**
 - 1st trimester only
 - Result ≥ 41 mmol/mol (or 5.9%)

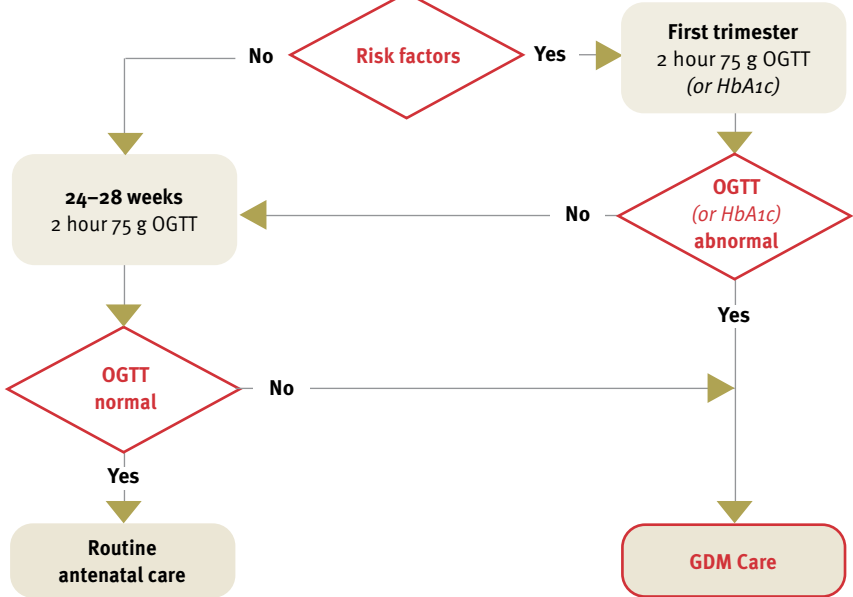

Flowchart adapted from: Qld Clinical Guideline *Gestational diabetes mellitus* (2021)

4. Management¹

- In addition to standard [Antenatal care, p. 364](#)
- Multidisciplinary approach recommended:
 - include the woman, midwife, obstetrician, endocrinologist (or physician experienced in diabetes care during pregnancy), diabetes educator + dietitian
 - consider optometrist and dentist input
 - ensure early referral(s)
- Provide advice on the importance of:
 - monitoring + controlling BGL during pregnancy
 - breastfeeding for mother + baby
- Provide emotional support to the woman

Pre-existing diabetes in pregnancy¹⁻³

- First antenatal visit should occur as soon as possible once pregnancy confirmed
- Initial evaluation may include:
 - usual antenatal testing. See [Antenatal care, p. 364](#)
 - serum glucose, HbA_{1c}, lipid profile, TSH, thyroid peroxidase antibodies, urine albumin/creatinine ratio, creatinine clearance, Hb, serum ferritin
 - recommend + continue high dose folate (5 mg/day) until 12 weeks gestation
- A management plan will be developed to achieve near-normal glycaemia. This may include:
 - individualised dietary advice
 - encouraging daily physical activity
 - self-monitoring BGL - fasting and 1–2 hours postprandial (after meals)
 - insulin in place of oral hypoglycaemics, titrated as needed
- Additionally specialist may consider:
 - examination of retina during each trimester, more frequent if retinopathy is present
 - USS monitoring of fetal growth + amniotic fluid volume 4 weekly from 28–36 weeks
 - close surveillance for new diabetes complications and monitoring of existing complications

Gestational diabetes mellitus (GDM)¹

- See **Antenatal schedule of care for GDM** (table)
- Suggested BGLs for GDM are:
 - fasting ≤ 5.0
 - 1 hour after commencing meal ≤ 7.4
 - 2 hours after commencing meal ≤ 6.7
- Insulin may be required for optimal control:
 - must be calculated and ordered by clinician with expertise in diabetes in pregnancy
 - will need regular review and titration to achieve glycaemic goals

Antenatal schedule of care for GDM

At initial GDM diagnosis	
Discuss/review/refer	Considerations
<input type="checkbox"/> Review history	Previous GDM, medications
<input type="checkbox"/> Diabetes educator consult	For GDM education within 1 week of diagnosis
<input type="checkbox"/> Dietitian review	Within 1 week of diagnosis
<input type="checkbox"/> Psychosocial assessment/support	Refer as required
<input type="checkbox"/> BGL self-monitoring	Commence self-monitoring
<input type="checkbox"/> BMI (pre-pregnancy)	Discuss healthy weight gain targets
<input type="checkbox"/> Physical activity, lifestyle advice	Include smoking cessation
<input type="checkbox"/> Baseline ultrasound scan (USS)	At 28–30 weeks
<input type="checkbox"/> Initial laboratory investigations	<input type="checkbox"/> Serum creatinine
<input type="checkbox"/> If diabetes in pregnancy (pre existing/ undiagnosed diabetes mellitus suspected)	<input type="checkbox"/> Optometrist/ophthalmologist review for diabetic retinopathy
	<input type="checkbox"/> Microalbuminuria for diabetic nephropathy
Each visit	
Discuss/review/refer	Considerations
<input type="checkbox"/> Clinical surveillance	Review for complications (eg pre-eclampsia)
<input type="checkbox"/> Weigh	Review weight gain trends, diet, exercise
<input type="checkbox"/> Test urine	Investigate ketonuria, proteinuria
<input type="checkbox"/> Review BGL self-monitoring record	Review patterns, trends and mean BGL
<input type="checkbox"/> Psychosocial assessment/support	Refer as required
<input type="checkbox"/> Fetal growth and wellbeing (abdominal circumference; USS 2–4 weekly as indicated)	
<input type="checkbox"/> If pharmacological therapy commenced	<input type="checkbox"/> Follow up contact within 3 days
	<input type="checkbox"/> Weekly diabetes educator review
	<input type="checkbox"/> Dietitian review
<input type="checkbox"/> Review suitability of model of care (Low risk not suitable if insulin or metformin required)	<input type="checkbox"/> Low risk GDM
	<input type="checkbox"/> Diabetic Clinic
	<input type="checkbox"/> Obstetric
	<input type="checkbox"/> Other
<input type="checkbox"/> Review next contact requirements (increase frequency if: suboptimal BGL, early diagnosis, diabetes in pregnancy, pharmacological therapy commenced)	<input type="checkbox"/> Fortnightly until 38 weeks
	<input type="checkbox"/> Fortnightly until 36 weeks
	<input type="checkbox"/> Weekly until birth
	<input type="checkbox"/> Other

Hypoglycaemia in pregnancy¹

- Fasting BGLs tend to decrease in pregnancy
- Levels of 3.5 may be physiologically normal and asymptomatic
- Hypoglycaemia is uncommon in women with GDM:
 - if asymptomatic confirm the accuracy of results prior to treatment
 - for symptoms. See [Hypoglycaemia, p. 91](#)
- Mild hypoglycaemia:
 - BGL $< 4.0 \pm$ symptoms of low BGL
- Severe hypoglycaemia:
 - BGL very low, generally < 3.0
 - confusion, potential loss of consciousness

Treating hypoglycaemia in women on glucose lowering medication¹

- Give 15 g serve of fast acting carbohydrates eg:
 - 5–7 glucose jelly beans
 - glass of soft drink - not diet
 - Lucozade® 100mL
 - 3 heaped teaspoons of sugar or honey dissolved in water
- If after 15 minutes symptoms persist or BGL < 4.0 :
 - repeat one serve of above
 - do not over treat with fast acting carbohydrates, as may lead to rebound hyperglycaemia
 - when BGL is ≥ 4.0 give sandwich, crackers, a glass of milk (longer lasting carbohydrate) or usual meal if within 30 minutes

5. Follow up

- As per individualised plan of care
- If GDM advise woman to be screened for:¹
 - persistent diabetes at 6–12 weeks postpartum using the OGTT and non-pregnancy diagnostic criteria
 - diabetes at least every 3 years and early glucose testing in future pregnancy

6. Referral/consultation

- Early referral for a multidisciplinary approach to care as per local protocols/individualised plan of care

HMP Hypertension in pregnancy

Recommend¹

- Severe hypertension in pregnancy is a life-threatening medical emergency
- Hypertension in pregnancy, chronic or newly arising, is a significant risk to the health of both the mother and her baby and must always be managed in consultation with an MO/obstetrician
- Correct BP cuff and measurement technique is critical for correct diagnosis

Background^{1,2}

- Pre-existing hypertension is a strong risk factor for preeclampsia
- **Transient gestational hypertension** - arises in 2nd and 3rd trimester. Settles after repeated BP readings (over several hours)
- **Gestational hypertension** - arises > 20 weeks, resolves within 3 months postpartum
- **Chronic hypertension** - confirmed preconception or < 20 weeks without a known cause (essential, secondary, white coat)
- **Preeclampsia, p. 386** - a multi-system disorder characterised by hypertension arising > 20 weeks. It involves 1 or more other organ systems ± the fetus
- **Preeclampsia superimposed on chronic hypertension** - woman with pre-existing hypertension develops systemic features of preeclampsia > 20 weeks
- Dipstick testing is the least accurate method to check for proteinuria (high false +ve):
 - where possible use PoCT and confirm proteinuria of $\geq 2+$ or repeated $1+$ with urine PCR²
- Also see Qld Clinical Guideline *Hypertension and pregnancy* <https://www.health.qld.gov.au/qcg/publications#maternity>

1. May present with²

- Pregnant woman with:
 - new onset of hypertension arising > 20 weeks
 - rise in sBP ≥ 30 and/or rise in dBP ≥ 15 from their booking in or preconception BP¹
 - pre-natal diagnosis of chronic hypertension with increase in BP

Hypertension in pregnancy ¹	
Mild to moderate hypertension	BP measured at least 4 hours apart, with elevation occurring at least twice: <ul style="list-style-type: none"> • Systolic BP (sBP) ≥ 140 (but < 160) and/or • Diastolic BP (dBP) ≥ 90 (but < 110)
Severe hypertension	<ul style="list-style-type: none"> • sBP ≥ 160 and/or dBP ≥ 110
Medical emergency	<ul style="list-style-type: none"> • sBP ≥ 170 with or without dBP ≥ 110

2. Immediate management¹

- Consult MO/NP urgently if:
 - severe hypertension
 - ± signs of [Preeclampsia, p. 386](#)
 - ± concerns about fetal wellbeing eg decreased fetal movements
- **If severe hypertension:**
 - **note:** woman may not appear ill. Do not delay treatment
 - insert IVC x 2 eg 16 G
 - **urgently consult MO/NP, who may advise** nifedipine ± hydralazine
 - **target BP:**
 - SBP 130–150 and dBP 80–90
 - aim for gradual and sustained ↓ BP so blood flow to the baby is not compromised
 - monitor BP 15–30 minutely until stable, then minimum 4 hourly
 - listen to FHR frequently + continuous CTG if > 24 weeks, if available
 - urgent evacuation required for obstetric care

S4	Nifedipine			Extended authority ATSHP/IHW/IPAP/MID/RIPRN
ATSHP, IHW, IPAP and RN must consult MO/NP				
RIPRN must consult MO/NP unless circumstances do not allow, in which case notify the MO/NP as soon as circumstances do allow				
MID may proceed to a max. of 2 doses				
Form	Strength	Route	Dose	Duration
Tablet (immediate release)	10 mg 20 mg	Oral	10–20 mg	stat May be repeated after 45 minutes on MO/NP orders (max. 80 mg)
Offer CMI: May cause nausea, headache, flushing, dizziness, hypotension or peripheral oedema				
Note: May increase effects of magnesium sulfate and risk of hypotension; use cautiously				
Contraindication: Cardiac disease				
Management of associated emergency: Consult MO/NP. See Anaphylaxis, p. 82				2,3

S4	Hydralazine			Prescribing guide
MID, RIPRN and RN only. Must be ordered by an MO/NP				
Form	Strength	Route	Dose	Duration
Injection	20 mg	IV	*Intermittent bolus dose 5–10 mg injected over 3–10 minutes Repeat doses of 5 mg, 20 minutes apart if required (max. 30 mg)	stat Cease if maternal HR > 125
			Infusion (via controlled infusion device) Commence at 10–20 mg/hour and titrate to BP	
Offer CMI: May cause tachycardia, headache, flushing or palpitations				
Note: *5 mg if fetal compromise. Monitor BP and HR continuously ⁴ during administration and until stable. For detailed administration advice see Appendix C of Qld Clinical Guideline <i>Hypertension and pregnancy</i> https://www.health.qld.gov.au/qcg/publications				
Contraindication: Severe or immediate allergic reaction to hydralazine. SLE, severe tachycardia, myocardial insufficiency and right ventricular heart failure				
Management of associated emergency: Consult MO/NP. See Anaphylaxis, p. 82				1,4

3. Clinical assessment^{1,2}

- Refer to midwife/MO/NP for clinical assessment. If midwife not available, complete what you can within your scope of practice and always consult MO/NP
- **Ask about:**
 - any symptoms of [Preeclampsia, p. 386](#)
 - fetal movements - normal, decreased, any concerns
 - any other symptoms
 - obstetric history:
 - current gestation, BP during this pregnancy
 - pre-existing proteinuria - if so, has this increased
 - past history. Ask about:
 - diabetes, kidney disease, endocrine disorders - Cushing's syndrome, SLE
 - known pre-natal hypertension
 - medicines
- **Do:**
 - vital signs
 - listen to FHR + every 30 minutes, or continuous CTG if > 24 weeks, if available
 - weight
 - urinalysis dipstick for protein - use point of care automated analyser if possible:
 - if $\geq 2+$ or repeated $1+$ proteinuria, or preeclampsia is suspected, obtain urine PCR
 - check for signs of [Preeclampsia, p. 386](#)
 - bloods - FBC, UEC, urate, LFT including LDH

4. Management^{1,2}

- Consult MO/NP in all cases of hypertension in pregnancy
- **If mild–moderate hypertension:**¹
 - MO/NP may consider oral antihypertensives if:
 - sBP persistently > 140 **and/or** dBP persistently > 90 on subsequent checks
 - and no signs/symptoms of preeclampsia
 - suggested targets sBP 110–140, dBP 85
- Further management as per MO/NP advice

5. Follow up^{1,2}

- MO/NP may refer for USS for fetal growth, amniotic fluid volume and umbilical artery doppler assessment
- Continued review/antenatal appointments according to the woman's clinical needs or MO/NP advice
- Advise woman to present immediately if any symptoms of preeclampsia

6. Referral/consultation

- As above

HMP Preeclampsia/eclampsia

Recommend¹

- Women with preeclampsia must be evacuated/hospitalised for obstetric care
- Magnesium sulfate is the preferred anticonvulsant for prevention + treatment of eclampsia

Background^{2,3}

- ↑ BP is commonly (but not always) the first manifestation. Correct BP cuff + measurement technique is critical for correct diagnosis
- **Preeclampsia** is a multi-system disorder characterised by hypertension arising > 20 weeks. It involves 1 or more other organ systems ± the fetus. Clinical progression is unpredictable¹
- **Eclampsia** is the development of 1 or more convulsions superimposed on preeclampsia in the absence of other neurological conditions that could account for the seizure¹
- Proteinuria is common but is not mandatory to make the clinical diagnosis¹
- Dipstick testing is the least accurate method to ascertain proteinuria (high false +ve). Where possible use PoCT + confirm proteinuria of ≥ 2+ or repeated 1+ with urine PCR
- Also see Qld Clinical Guideline *Hypertension and pregnancy* <https://www.health.qld.gov.au/qcg/publications#maternity>

1. May present with²

- Pregnant woman with hypertension arising > 20 weeks (confirmed on 2 or more occasions) AND with 1 or more **Features of preeclampsia**

Features of preeclampsia - in addition to hypertension ^{1,3}	
Features	<ul style="list-style-type: none"> • Proteinuria on dipstick - ≥ 2+ or repeated 1+ • Fetal growth restriction
Severe features	<p>May include any of:</p> <ul style="list-style-type: none"> • sBP ≥ 160 or dBP ≥ 110 (confirmation within 15–30 minutes is sufficient) • Persistent new ± severe headache • Visual disturbances eg blurred vision, flashing lights/sparks, dark areas/gaps in visual field, double vision, blindness in 1 eye • Altered mental state/confusion • Severe epigastric pain ± right upper quadrant pain • Hyper-reflexia and ankle clonus • Dyspnoea, pulmonary oedema • Oliguria, nausea ± vomiting • Reduced fetal movements • Stroke, biochemical changes of blood tests - HELLP syndrome
Imminent eclampsia	<p>At least 2 of:</p> <ul style="list-style-type: none"> • Frontal headache • Visual disturbance • Altered level of consciousness • Hyper-reflexia • Epigastric tenderness
Eclampsia	<ul style="list-style-type: none"> • Fitting

2. Immediate management^{1,2}

If fitting

- Send for help
- Urgently consult MO/NP
- Start resuscitative measures + give O₂ by mask
- Insert IVC x 2 eg 16 G
- Magnesium sulfate will be ordered by the MO/NP
- Give midazolam if:
 - seizures occur/ongoing while preparing magnesium sulfate OR
 - if seizures reoccur during giving of magnesium sulfate
 - **note:** most seizures are 1–3 minutes + may not require drug treatment
- Further management as per MO/NP, including:
 - urgent evacuation
 - vital signs every 5 minutes
 - insert IDC - measure urine output hourly, maintain strict fluid balance
 - RR + patella reflexes hourly
 - listen to FHR frequently - continuous CTG if > 24 weeks, if available

If features of severe preeclampsia or imminent eclampsia¹

- Urgently consult MO/NP, who may order:
 - nifedipine or hydralazine.¹ See [Hypertension in pregnancy, p. 383](#)
 - ± magnesium sulfate to prevent eclampsia¹
- Insert IVC x 2 eg 16 G
- Urgent evacuation
- Do vital signs every 5 minutes

S ₄	Midazolam		Extended authority ATSIHP/IHW/MID/RIPRN	
ATSIHP, IHW and RN must consult MO/NP				
MID and RIPRN may proceed				
Form	Strength	Route	Dose	Duration
Injection	5 mg/5 mL	IV/IM (ATSIHP and IHW may NOT administer IV)	5–10 mg	stat If IV, inject slowly over at least 2–5 minutes Further doses on MO order
	5 mg/1 mL			
	5 mg/1 mL	Buccal Intranasal		
Administration advice: Buccal: slowly drip into mouth between gums and cheek using a syringe or squeeze directly from the <i>plastic ampoule</i> . Intranasal: use mucosal atomisation device (MAD) or 1–3 drops (<i>plastic ampoule</i>), 1 at a time into alternative nostrils until full dose is given (over 15 seconds)				
Note: Monitor for sedation and respiratory depression				
Management of associated emergency: Consult MO/NP. See Anaphylaxis, p. 82				1,4,5

Unscheduled	Magnesium sulfate			Prescribing guide
MID, RIPRN and RN only. Must be ordered by an MO/NP				
Use local protocols for administration of magnesium sulfate if available				
Form	Strength	Route	Dose	Duration
Injection	2.5 g/5 mL	IV	Loading dose 4 g Draw up 8 mL (4 g) and dilute to 20 mL with sodium chloride 0.9%	Infuse over 20 minutes using syringe pump*
			Maintenance dose 1 g/hour (10 g) Draw up 20 mL (10 g) and dilute to a total of 50 mL with sodium chloride 0.9%	Infuse at 5 mL/hour for 24 hours using syringe pump
			New onset or persistent seizures while on magnesium sulfate Give a further 4 mL (2 g) diluted in 10 mL of sodium chloride 0.9%	Infuse over 5 minutes Repeat in 2 minutes if seizures persist
OR if using prefilled syringe - no dilution required				
Prefilled syringe (Baxter®)	4 g/20 mL	IV	Loading dose 4 g	Infuse over 20 minutes using syringe pump*
	10 g/50 mL		Maintenance dose 1 g/hour (10 g)	Infuse at 5 mL/hour for 24 hours using syringe pump
			New onset or persistent seizures while on magnesium sulfate Give a further 10 mL (2 g)	Infuse over 5 minutes Repeat in 2 minutes if seizures persist
Offer CMI: May cause nausea, vomiting or transient hot flushing				
Note: If impaired renal function, reduce maintenance dose to 0.5 g/hour. Observe for signs of toxicity.				
*If no syringe pump, push loading dose slowly over 20 minutes				
Management of associated emergency: Contact MO/NP. Cease infusion. Calcium gluconate should be readily available in case of respiratory depression/overdose. Hypotension alone will generally respond to IV fluids and parenteral calcium is rarely necessary. Also see Anaphylaxis, p. 82 1,2,7-9				

Unscheduled	Calcium gluconate			Prescribing guide
MID, RIPRN and RN only. Must be ordered by an MO/NP				
Form	Strength	Route	Dose	Duration
Injection	2.2 mmol/10 mL	IV	10 mL	stat Inject slowly over 5–10 minutes into a large peripheral vein
Offer CMI: Given for overdose of magnesium sulfate				
Note: High-risk medicine and is rapidly fatal in overdose. Extravasation can cause tissue necrosis				
Contraindication: Subcut and IM route				
Management of associated emergency: Consult MO/NP. See Anaphylaxis, p. 82 6,10				

If magnesium sulfate ordered¹

- See Qld Clinical Guideline *Hypertension and pregnancy* for detailed administration advice <https://www.health.qld.gov.au/qcg/publications#maternity> - or local policy
- **Before starting** have:
 - calcium gluconate drawn up in case of respiratory depression/overdose
 - resuscitation/ventilator support immediately available
 - dedicated IV line
 - do base line vital signs, patella reflex, abdominal palpation, FHR
- **During loading dose:**
 - vital signs 5 minutely until stable - for 20 minutes
 - SpO₂ continuously
 - listen to FHR 15–30 minutely - continuous CTG if > 24 weeks, if available
 - **monitor for signs of magnesium toxicity:** nausea, vomiting, flushing, hypotension, muscle weakness, muscle paralysis, blurred or double vision, CNS depression + loss of reflexes
- **After loading dose** - check patella reflex
- **Maintenance dose** - start after loading dose
- **Stop the infusion** + consult MO/NP immediately if:
 - RR < 12 or > 4 below baseline OR
 - absent patella reflex OR
 - dBP decreases > 15 below baseline

3. Clinical assessment^{2,3}

- Refer to midwife/MO/NP for clinical assessment. If no midwife available, complete what you can within your scope of practice + always consult MO/NP
- **Ask about:**
 - associated symptoms
 - signs of preeclampsia
 - fetal movements - normal, decreased, any concerns
 - current + previous pregnancy, any problems
- **Past history**, any:
 - renal disease, hypertension
 - risk factors for preeclampsia eg diabetes, first pregnancy, BMI > 30, past/family history of preeclampsia
- **Do:**
 - vital signs + listen to FHR
 - work out current gestation
 - patella reflex
 - dipstick for proteinuria, **note:** confirm proteinuria ≥ 2+ or repeated 1+ by urine PCR
 - check for signs of preeclampsia
- Take bloods - FBC, UEC, LFT including LDH, coagulation studies, group and hold

4. Management²

- Promptly contact MO/NP if hypertension in pregnancy with symptoms of preeclampsia
- Will likely require evacuation/hospitalisation for further investigations

5. Follow up⁶

- If not evacuated/hospitalised review according to MO/NP instructions
- Once a diagnosis of preeclampsia is established, testing for proteinuria is no longer useful
- Consult MO/NP promptly if BP raised again

6. Referral/consultation

- Consult MO/NP on all occasions of BP > 140/90 in pregnancy

HMP Antepartum haemorrhage (APH) Vaginal bleeding after 20 weeks pregnant

Recommend^{1,2}

- APH associated with maternal or fetal compromise should be treated as an obstetric emergency
- Suspect placenta praevia in any woman > 20 weeks who presents with vaginal bleeding

Background

- Also see Qld Clinical Guidelines *Early pregnancy loss + Primary postpartum haemorrhage* <https://www.health.qld.gov.au/qcg/publications#maternity>

1. May present with^{1,2}

- Pain without bleeding may be only symptom eg placental abruption
- Vaginal bleeding > 20 weeks pregnant - spotting to massive haemorrhage
- Signs of shock, **note:** shock may be late sign:^{1,4}
 - ↑ HR, ↓ BP, ↑ RR
 - restlessness
 - sweating
 - cool, clammy skin
 - ↓ urine output

2. Immediate management^{1,2,5}

- If bleeding very heavy or signs of shock:
 - call for help
 - consult MO/NP urgently
 - insert IVC x 2 eg 16 G
 - start sodium chloride 0.9% or Hartmann's 1000 mL - then as ordered by MO/NP
 - vital signs - continuously monitor or at least every 15 minutes
 - do rapid history/examination - **do not perform digital vaginal examination**
 - take blood for FBC, coagulation studies, group and x-match, LFT, UE
 - lie woman in left lateral position - not supine

3. Clinical assessment¹⁻³

- **Ask about:**
 - bleeding - amount, when did it start, any clots, gradual or sudden onset
 - did bleeding start after sex
 - pain - where, how severe, continuous/intermittent:
 - consider placental abruption if continuous, or labour if intermittent
 - recent trauma to abdomen - accidental or [Domestic and family violence, p. 241](#)

- fetal movements - normal, decreased or any concerns
- other symptoms/concerns
- **Check antenatal history:**
 - USS results if available - check location of placenta
 - estimate gestation based on dating scan or LNMP
 - blood group and antibody status
 - obstetric history - prior pregnancies/vaginal birth or caesarean, previous placenta praevia or placental abruption, miscarriages/ToP
- **Do:**
 - vital signs
 - check loss on pad - amount and rate of blood loss, weigh loss if possible
 - consider possibility of concealed bleeding - in uterine cavity
 - listen to FHR, needs confirming with USS if not heard
 - palpate abdomen - is uterus soft/hard, tender/non-tender, contracting
 - check fundal height
 - bloods - FBC, group and hold

4. Management^{1,3}

- Any bleeding heavier than spotting ± ongoing bleeding requires evacuation/hospitalisation
- Consult MO/NP who may advise:
 - insert IDC
 - corticosteroids if risk of preterm birth. See [Preterm labour, p. 397](#)
- Keep nil by mouth
- Offer analgesia. See [Acute pain, p. 32](#)
- Continue to monitor blood loss, pain + vital signs
- Listen to FHR every 30 minutes OR continuous CTG if > 24 weeks, if available
- If Rh D –ve with no pre-formed anti-D antibodies,⁶ offer [Rh D immunoglobulin, p. 369](#)
- Further management as per MO/NP

5. Follow up

- Offer grief counselling for parents who have experienced pregnancy loss

6. Referral/consultation

- As above

HMP Prelabour rupture of membranes (PROM)

Recommend

- If preterm, antibiotics are given to reduce the risk of infection to mother and baby + delay the onset of labour¹

Background

- Also see Qld Clinical Guidelines *Term prelabour rupture of membranes, Preterm prelabour rupture of membranes + Early onset Group B Streptococcal Disease* <https://www.health.qld.gov.au/qcg/publications>

1. May present with^{1,2}

- Gush of fluid from vagina
- Intermittent or constant leaking of small amounts of fluid
- Sensation of wetness
- Seeing or feeling umbilical cord protruding from vagina

2. Immediate management⁵

- If umbilical cord is protruding treat as an obstetric emergency. See [Cord prolapse, p. 415](#)
- Listen to FHR - normal is 110–160:
 - if tachycardia or bradycardia:
 - reposition woman + recheck
 - check for cord prolapse
 - contact MO/NP urgently

3. Clinical assessment¹⁻³

- Wherever possible a woman who is thought to have ruptured membranes should be assessed by a midwife or MO/NP
- **Ask about:**
 - when did she first notice the fluid - date/time
 - how much - gush, small leak, just wetness
 - still leaking
 - colour of fluid - clear, yellow, green, bloody
 - any odour
 - fetal movements - normal, decreased or any concerns
 - abdominal or pelvic pain, contractions
 - fever, nausea/vomiting
 - other symptoms/concerns eg UTI + STI⁵
- **Ask about** this pregnancy:
 - antenatal history - check records/pathology results eg GBS status
 - grvida/para
 - estimated gestation based on dating scan or LNMP
 - USS reports
 - concerns or problems - diabetes, hypertension
 - STI tests - when, results, treatment
- **Get past history:**
 - medicines, allergies

- reproductive, sexual history
- **Do:**
 - vital signs
 - listen to FHR OR continuous CTG if > 24 weeks, if available
 - check vaginal loss on pad - amount, colour, consistency, odour, bleeding, meconium stained
 - abdominal palpation - tenderness, fundal height, fetal lie + presentation, contractions (strength/length/frequency)
- Avoid digital vaginal examination - may increase risk of infection^{1,2}
- Sterile speculum examination **if skilled to:**
 - exclude cord prolapse
 - observe the cervix for dilation/length
 - check for pooling of amniotic fluid or leakage from the cervical os with coughing:
 - if not obvious, AmniSure® or pH indicator eg Nitrazine® can be used^{1,2}
 - take:
 - LVS-anal swab for GBS
 - HVS for chlamydia, gonorrhoea and trichomonas PCR
 - additional HVS for MCS if indicated
- **Take pathology:**
 - urinalysis and MSU for MCS
 - FBC, CRP + antenatal bloods if not already collected
 - if no speculum examination, get self or clinician collected swabs:
 - LVS for chlamydia, gonorrhoea and trichomonas PCR¹
 - LVS-anal swab for GBS⁶
 - **note:** if unable to collect swab do FCU for chlamydia, gonorrhoea + trichomonas PCR

How to take a swab for culture for GBS⁶

- Either vaginal-rectal swab OR vaginal-perianal swab. **Woman may self collect**
- Use one single dry swab stick - insert 2–4 cm into vaginal opening + then:
 - for vaginal-anorectal - insert into anus
 - for vaginal-perianal - swab the surface outside of the anus
 - place into standard bacterial transport medium
 - label 'GBS screening in pregnancy'

4. Management^{1,2}

- Consult MO/NP on all occasions
- MO/NP may advise:
 - evacuation/hospitalisation
 - if < 37+0 weeks, antibiotics:⁶
 - IV ampicillin PLUS oral erythromycin
 - + ongoing antibiotics as per MO/NP
 - if < 35 weeks give betamethasone to accelerate fetal lung maturation.¹ See [Preterm labour, p. 397](#) for doses
 - **note:** if > 35 weeks betamethasone may still be indicated - check with MO/NP⁸
 - magnesium sulfate if < 30 weeks + birth likely in 24 hours.¹ This is done in consultation with tertiary centre. If ordered see [Magnesium sulfate drug box, p. 388](#) for guidance
- Monitor woman + listen to FHR/CTG until evacuation as per MO/NP instructions

S ₄	Ampicillin			Extended authority ATSIHP/IHW/IPAP
ATSIHP, IHW, IPAP, MID, RIPRN and RN must consult MO				
Form	Strength	Route	Dose	Duration
Injection	500 mg 1 g	IV	2 g	stat Inject over 10–15 minutes <i>More rapid injection may cause seizures</i>
Offer CMI: May cause rash, diarrhoea, nausea and pain at injection site				
Contraindication: Severe hypersensitivity to penicillins, carbapenems and cephalosporins. Do not mix with aminoglycosides eg gentamicin				
Management of associated emergency: Consult MO/NP. See Anaphylaxis, p. 82 6,10,11				

S ₄	Erythromycin			Extended authority ATSIHP/IHW/IPAP
ATSIHP, IHW, IPAP, MID, RIPRN and RN must consult MO				
Form	Strength	Route	Dose	Duration
Capsule	250 mg	Oral	250 mg	stat
Offer CMI: Take on an empty stomach 1 hour before or 2 hours after food. May cause nausea, vomiting, diarrhoea, abdominal pain/cramps or thrush. Can be taken with food if causes stomach upset				
Contraindication: Use with some statins. Severe or immediate allergic reaction to macrolides. Severe hepatic impairment. Use with caution in patients with myasthenia gravis				
Management of associated emergency: Consult MO/NP. See Anaphylaxis, p. 82 6,9				

5. Follow up

- Evacuation/hospitalisation for ongoing management

6. Referral/consultation

- As above

Labour and birth

HMP Group B Streptococcus prophylaxis

Background^{1,2}

- Group B *Streptococcus* (GBS) in the pregnant woman's vagina increases the risk of the newborn baby getting sepsis. Antibiotics are given to the woman during labour to reduce this risk
- Also see Qld Clinical Guideline *Early onset group B streptococcal disease* <https://www.health.qld.gov.au/qcg/publications#maternity>

1. May present with

- Pregnant woman during antenatal visit, or in labour

2. Immediate management Not applicable

3. Clinical assessment¹

- Assess for **Group B Strep (GBS) risk factors**

Group B Strep (GBS) risk factors - any of	
Antenatal	
<input type="checkbox"/>	Previous baby with early onset Group B Strep disease
	Group B Strep detected in this pregnancy eg:
<input type="checkbox"/>	<ul style="list-style-type: none"> • urine pathology test • vaginal swab - note routine swabs for GBS are not done in Qld
During labour	
<input type="checkbox"/>	Any of the above risk factors
<input type="checkbox"/>	Preterm labour < 37+0 weeks: <ul style="list-style-type: none"> • Intact OR ruptured membranes
<input type="checkbox"/>	Mother has T ≥ 38*
<input type="checkbox"/>	Membranes have ruptured: <ul style="list-style-type: none"> • > 14 hours and birth unlikely by 18 hours OR • > 18 hours
*Or signs of chorioamnionitis: febrile; offensive smelling vaginal discharge; tender abdomen without contractions	

- Document in medical record
- Advise woman **antibiotics are recommended during labour** + to alert staff to this
- Give information about GBS + antibiotics. See *Consumer information* <https://www.health.qld.gov.au/qcg/publications#maternity>

- Give **Antibiotics during labour**
- Aim to give at least 4 hours before birth

4. Management¹

If antibiotics indicated during labour

- **If maternal T ≥ 38** consult MO/NP, who will:
 - order broad spectrum antibiotics that include an agent active against GBS (instead of antibiotics below), and
 - seek urgent advice from neonatologist/paediatrician
- **In all other cases**, if not allergic, give:
 - IV benzylpenicillin 3 g at the onset of labour
 - followed by IV benzylpenicillin 1.8 g every 4 hours until birth

- If allergic to penicillin:
 - IV lincomycin 600 mg 8 hourly
- A baby born to a woman at risk of GBS should be evacuated for neonatal/paediatric review as soon as possible

If antibiotics are given < 2 hours before birth ie birth too quick:¹

- Urgent paediatric/neonatal advice needed - baby is at ↑ risk of infection/sepsis
- **If baby < 37+0 weeks OR has signs of sepsis** eg respiratory distress, unstable temperature, they need:
 - antibiotics within 30 minutes of birth
 - FBC + blood cultures
- **If baby ≥ 37+0 weeks** they need:
 - FBC + observation for signs of infection for 48 hours

S4	Benzylpenicillin			Extended authority ATSIHP/IHW/IPAP/MID	
ATSIHP, IHW, IPAP, RIPRN and RN must consult MO/NP					
MID may proceed					
Form	Strength	Route	Dose	Duration	
Injection	600 mg 1.2 g 3 g	IV Reconstitute with 10 mL water for injections, then dilute in 100 mL sodium chloride 0.9%	First dose 3 g	At onset of labour	
			Ongoing doses 1.8 g	4 hourly after first dose until birth	
Offer CMI: May cause diarrhoea or nausea					
Note: Rapid IV injection of large doses may cause seizures. Infuse over 30 minutes to 1 hour					
Contraindication: Severe or immediate allergic reaction to a penicillin. Be aware of cross-reactivity between penicillins, cephalosporins and carbapenems					
Management of associated emergency: Consult MO/NP. See Anaphylaxis, p. 82 1,3,4					

S4	Lincomycin			Extended authority ATSIHP/IHW/IPAP/MID	
ATSIHP, IHW, IPAP, RIPRN and RN must consult MO/NP					
MID may proceed					
Form	Strength	Route	Dose	Duration	
Injection	600 mg/ 2 mL	IV Dilute in 100 mL sodium chloride 0.9%	600 mg	8 hourly until birth	
				Infuse over at least 1 hour	
Offer CMI: May cause nausea, vomiting, diarrhoea, abdominal pain or cramps					
Note: If renal or hepatic impairment seek MO/NP advice. Must only be given by slow IV infusion - IV injection can cause severe cardiopulmonary reactions					
Contraindication: Severe or immediate allergic reaction to clindamycin or lincomycin					
Management of associated emergency: Consult MO/NP. See Anaphylaxis, p. 82 1,5,6					

5. Follow up

- As per MO/NP

6. Referral/consultation

- Consult MO/NP as above

HMP Preterm labour

< 37+0 weeks gestation

Recommend

- Aim for in utero transfer wherever possible. If < 28 weeks, accept a high level of risk for birth occurring en route, unless it puts mother's life at risk¹

Background

- Also see Qld Clinical Guidelines *Preterm labour and birth ± Perinatal care of the extremely preterm baby* <https://www.health.qld.gov.au/qcg/publications#maternity>

1. May present with¹

- Contractions - abdominal pain + tightening that comes and goes ±
 - rupture of membranes (ROM)
 - a show - passage of bloody mucous
 - lower back pain

2. Immediate management

- If birth is imminent. See [Imminent birth, p. 403](#) + [Neonatal resuscitation, p. 408](#)
 - send for help + contact MO/NP urgently

3. Clinical assessment¹

- Assess by a midwife or MO/NP wherever possible
- Use prompts in [Labour 1st stage, p. 400](#) to ask about:
 - this presentation
 - pregnancy
 - past history
- Do physical examination, including:¹
 - vital signs
 - palpate abdomen, if skilled, check:
 - uterine tone, uterine activity/contractions, fundal height, presentation
- Listen to FHR + CTG if available
- Do sterile speculum examination, if skilled:¹
 - fetal fibronectin test (see table), before any examination of the cervix/vagina¹
 - check if ROM ± liquor - clear, meconium stained, bloody, pink
 - visualise cervix and membranes¹
 - HVS + MCS
- LVS-anorectal swab for Group B Strep. See [PROM, p. 392](#) for technique
- MSU + MCS¹
- MO/NP may advise to check cervical dilatation by sterile digital vaginal examination. Do not do if membranes ruptured or suspected placenta praevia¹

Fetal fibronectin (fFN) testing - measures the likelihood of preterm birth¹

Indications	<ul style="list-style-type: none"> Symptomatic preterm labour between 22+0 to 36+0 weeks AND intact membranes AND cervical dilatation \leq 3 cm
How to do	<ul style="list-style-type: none"> Follow test kit instructions Take the sample from posterior fornix of vagina Only use sterile water as lubricant
<p>Contraindications: Cervical dilatation $>$ 3 cm, ROM, cervical stitch in situ, presence of soaps, gels, lubricants or disinfectants. Relative contraindications: Visual evidence of moderate or gross bleeding, within 24 hours of sexual intercourse</p> <p>Results:</p> <ul style="list-style-type: none"> fFN $<$ 50 ng/mL (negative) suggests low risk of birth within 7–14 days fFN \geq 50 ng/mL (positive) suggests increased risk of preterm birth <p>Note: be aware of false negative/positive results. Contact MO/NP regardless of result</p>	

4. Management

- Insert IVC x 2
- Consult MO/NP early, who will:¹
 - arrange evacuation to an obstetrics facility with neonatal capability
 - \pm order transvaginal USS to assess cervical length
 - advise medication as per **Management guide** below
 - advise on [Observations during labour, p. 402](#)/other monitoring until evacuation

Management guide¹

< 34 weeks	<ul style="list-style-type: none"> Nifedipine to delay birth. If given, monitor: <ul style="list-style-type: none"> – FHR after contractions or CTG until contractions cease – BP, HR + RR every 30 minutes for 1 hour, then hourly
< 35+0 weeks	<ul style="list-style-type: none"> Betamethasone to accelerate fetal lung maturation: <ul style="list-style-type: none"> – monitor BGL after giving if diabetes
< 30+0 weeks	<ul style="list-style-type: none"> Magnesium sulfate if birth likely in 24 hours on MO/NP order, for fetal neuroprotection. Same doses as for Preeclampsia, p. 386
In all cases	<ul style="list-style-type: none"> If labour continues OR there is risk of birth within 24 hours: <ul style="list-style-type: none"> – give IV antibiotics for Group B Strep, p. 395 If signs of chorioamnionitis eg T $>$ 38, HR $>$ 100, FHR $>$ 160, uterine tenderness, offensive vaginal discharge: <ul style="list-style-type: none"> – labour should not be stopped. MO/NP will order IV antibiotics

S4	Betamethasone			Extended authority ATSIHP/IHW/IPAP/MID
ATSIHP, IHW, IPAP, RIPRN and RN must consult MO/NP				
MID may proceed				
Form	Strength	Route	Dose	Duration
Injection	5.7 mg/mL	IM	11.4 mg	stat Further doses on MO/NP order
Offer CMI: Given to prevent neonatal respiratory distress syndrome				
Management of associated emergency: Consult MO/NP. See Anaphylaxis, p. 82				

1,3

S ₄	Nifedipine			Extended authority ATSIHP/IHW/IPAP/MID
ATSIHP, IHW, IPAP, RIPRN and RN must consult MO/NP				
MID may proceed to a max. of 2 doses				
Form	Strength	Route	Dose	Duration
Tablet (immediate release)	10 mg 20 mg	Oral Crush or chew first 2 doses to increase rate of absorption	20 mg	stat Repeat dose after 30 minutes if contractions persist MO/NP may order another dose if contractions persist for a further 30 minutes
Offer CMI: May cause nausea, headache, flushing, dizziness, hypotension or peripheral oedema				
Note: May increase effects of magnesium sulfate and risk of hypotension; use cautiously				
Contraindication: Maternal hypotension, cardiac disease; any condition that would make prolongation of pregnancy hazardous				
Management of associated emergency: Consult MO/NP. See Anaphylaxis, p. 82				

1,2

5. Follow up

- Evacuation/hospitalisation for ongoing management

6. Referral /consultation

- As above

HMP Labour 1st stage

Recommend

- Birth during transport should be avoided unless there is significant risk to mothers life

Background¹

- This topic is intended for facilities that do not have planned births
- First stage of labour:
 - latent phase - irregular painful contractions, some cervical effacement
 - active phase (established labour) - regular painful contractions AND cervical effacement + dilatation of at least 4–6 cm. During this stage dilatation of 0.5 cm per hour is accepted progress
- Qld Intrapartum Record Form <https://clinicalexcellence.qld.gov.au/resources/clinical-pathways/maternity-clinical-pathways> (ordered through local health service)

1. May present with¹

- Contractions - abdominal pain and tightening that comes and goes ±
 - rupture of membranes
 - a show - passage of bloody mucous
 - lower back pain

2. Immediate management

- **Check for signs of Imminent birth, p. 403** ie:
 - urge to push/need to open bowels
 - vulval gaping/bulging, anal dilation, baby visible
 - shakiness, irritability, nausea and vomiting - could be transitioning to birth

3. Clinical assessment¹

- Wherever possible a woman who is thought to be in labour should be assessed by a midwife/MO
- **Ask about:**
 - contractions - when started, frequency, duration, strength/pain, regular/irregular
 - if membranes ruptured - when, colour, amount, odour
 - vaginal loss - discharge, blood
 - fetal movements - normal or decreased
- **Ask about the pregnancy** ± check *Pregnancy health record*:
 - weeks pregnant (dating scan most accurate):
 - preterm < 37 + 0 weeks. **If preterm, go to Preterm labour, p. 397**
 - term ≥ 37 weeks
 - antenatal care; where
 - one baby/more
 - complications during pregnancy eg hypertension, gestational diabetes, syphilis
 - how many pregnancies and births (gravida/para); vaginal births or caesareans, birth complications eg PPH, shoulder dystocia
 - medicines, allergies
 - relevant medical, gynaecological, surgical, social history
- **Check results:**
 - USS for placental position
 - Hb, syphilis, blood group (check if negative)

- **Assess Group B Strep risk.** See [GBS prophylaxis, p. 395](#)
 - if at risk, will need antibiotics during labour, as baby at risk of sepsis

Do physical examination¹

- Vital signs + urinalysis
- Vaginal loss - discharge, blood, liquor. Note colour, odour, amount, consistency
- **Feel contractions** - rest hand on abdomen and feel tightening:
 - note strength, frequency and length of each contraction over 10 minutes
 - regular/irregular
- **Listen to baby's heart rate (FHR)** if skilled:
 - normal is 110–160/minute:
 - differentiate between the baby's and mothers HR by taking radial pulse of mother at same time
 - if bradycardia or tachycardia, ask woman to change position and recheck - urgently contact MO/ NP if still abnormal
 - consider CTG if available
- **Palpate abdomen** if skilled:
 - fundal height (cm) - measure suprapubic bone to top of uterus (fundus), may indicate gestation
 - fetal lie - longitudinal, transverse, oblique
 - presentation - cephalic (head), breech (buttocks/bottom)
 - position eg right occiput anterior (ROA)
 - descent into pelvic brim - 5ths of fetal head palpable above the symphysis pubis
- **Vaginal examination (VE)** (between contractions) **only if skilled:**
 - **do not do if** - antepartum haemorrhage, rupture of membranes and not in labour, placenta praevia, placental position unknown, suspected [Preterm labour, p. 397](#)
 - first, listen to FHR, ensure bladder empty, palpate abdomen
 - note - liquor, cervix dilatation + effacement, consistency (soft/firm), application of presenting part, membranes intact/not felt, level of presenting part to ischial spines (–3 to +3), fetal position
 - post VE listen to FHR
- If prelabour rupture of membranes (PROM) do speculum examination instead

4. Management¹

- Contact MO/NP early for advice:
 - **if woman is in labour** a decision will need to be made as to whether there is time to evacuate or if the woman will birth in the community
 - consider gestation, parity, stage of labour on presentation, labour progression, staff availability/skill level
 - if evacuation, ensure pregnancy health records/antenatal records go with woman
 - if birth in the community - prepare/check equipment; ensure assistance available
- Insert IVC x 2 eg 14–16 G
- **Support and reassure:**
 - ensure privacy, calmness; involve support person/partner
 - assist to comfortable position(s). Encourage upright positions
 - avoid lying flat on back, as can cause supine hypotension
 - encourage to drink to thirst, offer light food as desired
- **If membranes rupture:**¹
 - check FHR immediately. If abnormal do VE to check for [Cord prolapse, p. 415](#)
 - note time + colour of fluid (liquor)

Observations during labour ¹	
15–30 minutely	<ul style="list-style-type: none"> • Fetal heart rate - listen towards end of contraction + 30–60 seconds after contraction finished: <ul style="list-style-type: none"> – there should be no slowing of FHR after a contraction. If it slows, ask the woman to change her position and recheck. If still slow, consult MO/NP urgently
30 minutely	<ul style="list-style-type: none"> • Contractions - feel for 10 minutes. Expect 3–5 in 10 minutes, lasting for 60–90 seconds, with 60 seconds resting tone • HR, RR
Hourly	<ul style="list-style-type: none"> • Vaginal loss
2nd hourly	<ul style="list-style-type: none"> • Encourage to empty bladder. Monitor
4 hourly	<ul style="list-style-type: none"> • BP, T - if elevated urgently consult MO/NP: <ul style="list-style-type: none"> – if T ≥ 38 MO/NP will order broad spectrum antibiotics that includes an active agent against GBS + seek urgent advice from neonatologist/paediatrician² – if BP elevated, see Preeclampsia, p. 386 • VE - more often if needed
As needed	<ul style="list-style-type: none"> • Abdominal palpation

- **Offer pain relief as needed:**¹
 - try non-pharmacological approaches as long as possible eg mobilisation, shower, massage, heat, breathing techniques. If needed, offer:
 - nitrous oxide + O₂ (Entonox®)
 - if still no relief and birth not imminent offer:
 - morphine (single dose). See [Acute pain, p. 32](#)
 - give lowest dose possible for adequate pain relief to minimise side effects
 - ± antiemetic. See [Nausea and vomiting, p. 40](#)
- **A non-midwife must get an MO/NP order for analgesia**

S4	Nitrous oxide + oxygen (Entonox®)			Extended authority ATSIHP/IHW/IPAP/MID	
ATSIHP, IHW, IPAP, RIPRN and RN must consult MO/NP					
MID may proceed					
Form	Strength	Route	Dose	Duration	
Premix gas	Nitrous oxide 50% + oxygen 50%	Inhalation	Self administered as needed	As required	
Offer CMI: Woman to hold mouthpiece or mask herself. Start at onset of contraction/30 seconds prior, continue until contraction eases. Takes effect in 20–30 seconds. May cause dizziness, nausea and brief disinhibition					
Note: Monitor sedation score + RR. Use with caution if vitamin B12 deficiency or if opioid given					
Management of associated emergency: Consult MO/NP. Give oxygen if overdose 1,3					

5. Follow up

- As per MO/NP

6. Referral/consultation

- As above

HMP Imminent birth

Recommend

- Avoid birth during transport if at all possible

Background^{1,2}

- This topic is intended for facilities that do not have planned births
- Episiotomy is generally only indicated if fetal compromise is evident. Not routine for preterm birth
- Intrapartum Record Form at <https://clinicalexcellence.qld.gov.au/resources/clinical-pathways/maternity-clinical-pathways> (ordered through local health service)
- Imminent Birth education program for rural + remote non-midwives at <https://www.health.qld.gov.au/employment/professional-development/online-education>

1. May present with¹

- Urge to push/bear down/open bowels
- Bulging perineum/anal dilation
- Baby is visible

2. Immediate management

- Stay with woman
- Send for help
- Get midwife/NP/MO to assess woman whenever possible
- Stay calm
- Ensure woman is in a safe, comfortable place; reassure and respect her privacy
- Prepare equipment eg emergency birth kit
- Use appropriate PPE
- **Ask assistant to:**
 - contact MO/NP for advice
 - insert IVC x 2 eg 14–16 G
 - draw up IM oxytocin 10 units¹ - kept in fridge
 - **prepare to care for baby.** See [Neonatal resuscitation, p. 408](#):
 - turn on/prepare incubator if available + warm towels/blanket(s) + hat
 - prepare [Neonatal resuscitation, p. 408](#) equipment ± warm room
 - will likely need resuscitation if preterm, especially if < 35 weeks

3. Clinical assessment^{1,3}

- Get rapid history as able ± check *Pregnancy health record*:
 - gestation - how many weeks pregnant; most accurate via dating scan:
 - term ≥ 37 weeks
 - preterm < 37+0 weeks - manage birth the same as term
 - gravida/para - how many pregnancies + births
 - have membranes ruptured - when/colour of fluid
 - fetal movements - normal or decreased
 - antenatal care - any problems
 - [Group B Strep, p. 395](#) risk, syphilis, diabetes, hypertension
 - allergies, medicines
 - any significant medical history

4. Management¹

- Encourage to adopt a comfortable position. Avoid lying flat
- If analgesia required offer nitrous oxide + O₂ (Entonox®). See [Labour 1st stage, p. 400](#)
- Support woman to use her own pushing instincts - do not tell her when/how hard to push

Monitor¹

- Fetal heart rate (FHR) - towards end of each contraction for at least 1 minute, or at least 5 minutely:^{1,7,8}
 - normal 110–160.⁸ **If abnormal, it could mean baby is distressed**
 - it is normal for FHR to drop during a contraction, but it should pick up again quickly
 - check mothers pulse simultaneously to differentiate between the two⁸
- Mothers HR + RR 15 minutely; BP + T 4 hourly
- Contractions - continually; frequency, strength, length
- Vaginal loss - continually

The birth^{1,3}

- If **feet or bottom presenting** instead of head, see [Breech birth, p. 426](#)
- **Perineum will stretch** as the head/presenting part comes down with contractions:
 - prevent faecal contamination from the anal area using a pad as needed
 - encourage woman to breathe gently/pant her baby's head out in a slow and controlled way
 - have 'hands on' head OR 'hands poised' on head and perineum²
 - no need to place firm pressure to maintain flexion of head
- If **fetal distress** and birth is being blocked by perineal tissue, consider [Episiotomy, p. 407](#) to expedite (if skilled + mother consents)²
- **Once head born** (note time):
 - no need to check for cord around neck¹
 - do not rush to birth the body
 - wait for next contraction and internal rotation - the head will turn sideways
 - with the next contraction, the shoulders should gently emerge:
 - usually the anterior shoulder slips out first (symphysis pubis side), followed by posterior
 - support the baby and lift onto the mother's abdomen
 - **note time of birth**
 - dry baby and remove wet towel(s)
 - cover with dry warm blanket + encourage skin to skin contact with mother
- If **shoulders do not birth** place a hand on either side of the baby's head and apply gentle axial traction in line with baby's spine. If still not releasing, see [Shoulder dystocia, p. 422](#)
- **Get assistant to check baby** within 15 seconds:
 - tone, breathing, HR

Immediately after birth³

- Check for another baby - the top of the uterus should be no higher than the umbilicus and firm
- **THEN** give **IM oxytocin** to mother (before cord clamped)
- **Wait at least 1–3 minutes or for cord pulsation to cease - then clamp and cut the cord:**^{1,3}
 - do not clamp < 1 minute unless baby needs resuscitating away from mother
 - clamp 10 cm from baby's abdomen. Then place 2nd clamp 5 cm from the 1st (on placenta side)
 - cut cord between the clamps
- **Deliver placenta** using **Controlled cord traction**¹ (if skilled) - if not skilled get MO/NP advice

S ₄	Oxytocin	Extended authority ATSIHP/IHW/MID/RIPRN		
ATSIHP, IHW and RN must consult MO/NP				
MID and RIPRN may proceed				
Form	Strength	Route	Dose	Duration
Injection	5 units/mL, 10 units/mL	IM	10 units	stat
Offer CMI: May cause nausea and vomiting				
Management of associated emergency: Consult MO/NP. See Anaphylaxis, p. 82				1,3,4

Controlled cord traction (CCT)^{1,3}

- Check oxytocin has been given to mother
- Reclamp cord closer to vaginal opening
- **WAIT for signs of separation** before CCT:
 - feel uterus rise in the abdomen + become firmer and globular (ballotable)
 - trickle or gush of blood from vagina
 - lengthening of the cord
 - cord does not retract with suprapubic pressure
 - woman may feel urge to bear down
 - placenta may be seen at vagina
- Avoid repeated palpation of uterus
- Use 1 hand to guard uterus with gentle pressure just above the symphysis pubis (counter traction)
- Then, with other hand gently apply downwards traction of cord
- As placenta delivers, hold in both hands and gently turn to twist/tease out the membranes
- **If the placenta does not descend during 20–30 seconds** of CCT or there is **resistance to CCT**:
 - stop pulling on cord - risk of breaking it or uterine inversion
 - hold cord loosely - without any pulling/traction, and wait
 - with next contraction, repeat CCT as above. If still not **coming > 30 minutes, consult MO/NP**

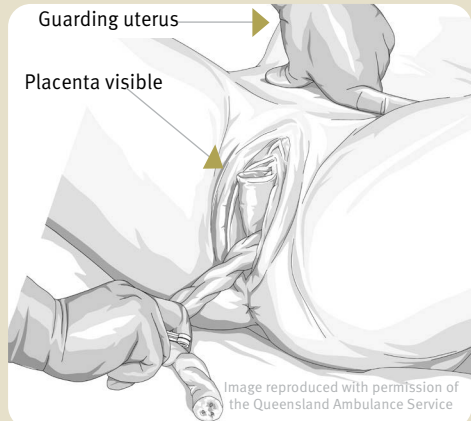

Be alert to uterine inversion - check fundus is felt in abdomen prior to CCT

Post birth of the placenta and membranes^{1,3}

- Immediately check top of uterus/**fundus is firm and central**:
 - massage the uterus if needed to ensure it remains contracted - may be uncomfortable
- Note the time
- **Estimate blood loss:**⁵
 - if heavy or persistent or ≥ 500 mL at any time, see [Primary PPH, p. 417](#)
 - if ≥ 350 mL, consider misoprostol 800 microg to help prevent PPH if in low resource area. See [Primary PPH, p. 417](#) for drug box
 - observe mother's vital signs for signs of haemorrhage eg \uparrow HR, \uparrow RR, colour
- **Check placenta and membranes** promptly (if skilled):
 - if not skilled, send with woman when evacuated
 - **if syphilis during pregnancy**, send placenta for histopathologic examination \pm cord PCR⁶
 - if needed, store/transport fresh or with sodium chloride 0.9%⁶ OR dispose as per mother's wishes (woman has right to take placenta home)

Placenta and membrane check¹

Placenta	<ul style="list-style-type: none"> • Complete or parts missing, general shape/appearance, any calcification, infarctions, evidence of abruption, succenturiate lobe
Membranes	<ul style="list-style-type: none"> • Complete or ragged, 1 amnion and 1 chorion, presence of vessels
Cord	<ul style="list-style-type: none"> • Insertion site; note if velamentous insertion (vessels in membranes) • 2 arteries and 1 vein • Collect cord blood if: <ul style="list-style-type: none"> – mother is Rh D –ve/unknown, for group and direct antiglobulin test (Coombs') (6 mL into EDTA tube + 5 mL into clotted blood tube) ± – preterm - FBC and blood cultures
Consult MO/NP if placenta looks incomplete; or offensive odour (+ get culture swab), or any other abnormality noticed	

Post-birth care¹

- First 1–2 hours post birth do not leave the mother and baby alone:
 - continue skin to skin contact; encourage breastfeeding
 - avoid unnecessary mother-baby separation
- Ensure comfort and personal hygiene needs, offer food; encourage drinking and mobilisation

Post birth observations and care^{1,3,9}

15–30 minutely for 1st 2 hours	<ul style="list-style-type: none"> • Vital signs (if T ↑ contact MO promptly) • Uterus (fundus) - should be firm and central (like a ball). If not, massage gently ± encourage to pass urine • Perineum + blood loss - be alert to a slow steady trickle
After first observations	<ul style="list-style-type: none"> • Inspect for perineal/vaginal trauma/tears: <ul style="list-style-type: none"> – offer pain relief eg nitrous oxide + O₂ (Entonox®). See Labour 1st stage, p. 400 – using good lighting, gently examine the vaginal walls and perineum using a piece of gauze wrapped around your gloved fingers – with consent, assess for anal sphincter injury (if skilled) – control bleeding from tears with direct pressure – do not attempt to repair unless trained. Can be left for receiving hospital
As needed	<ul style="list-style-type: none"> • Pain level
Within 2 hours	<ul style="list-style-type: none"> • Empty bladder
Within 6 hours	<ul style="list-style-type: none"> • Do venous thromboembolism (VTE) risk assessment: <ul style="list-style-type: none"> – eg see <i>VTE prophylaxis in pregnancy and the puerperium</i> https://www.health.qld.gov.au/qcg/publications
If Rh D –ve blood group or unknown	<ul style="list-style-type: none"> • Take bloods for Kleihauer • Rh D immunoglobulin, p. 369 needed within 72 hours if baby's blood group positive/unknown (receiving hospital can do this)
Syphilis bloods⁶	<ul style="list-style-type: none"> • Take bloods for syphilis serology if: syphilis during pregnancy, at High risk of syphilis, p. 368, no serology after 26–28 weeks AND woman at Increased risk of syphilis, p. 368, or preterm birth with most recent serology > 4 weeks before birth

Episiotomy²

- Only midwife/NP/MO should do episiotomy. Ensure consent from woman
- Infiltrate with lidocaine (lignocaine) 1%
- Place two fingers in the vagina, position blades of episiotomy scissors between fingers
- Make a 4–5 cm cut at **60° angle**, right side (generally) of perineum at the height of the contraction, with descent of the fetal head (presenting part) just prior to crowning
- Immediately control the birth of the head to prevent further tearing
- Apply pressure to the episiotomy between contractions if there is a delay in the birth
- Repair should ideally be done promptly, however only by a clinician skilled in perineal repair

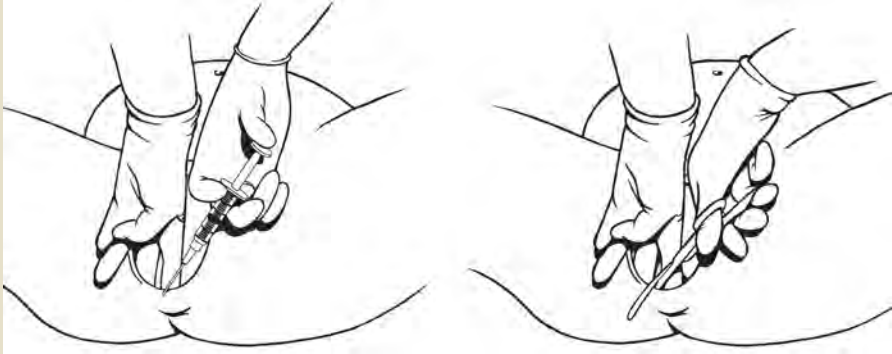

5. Follow up

- MO/NP will consider evacuation after birth. If not evacuated, advise to return promptly if T elevated within 24 hours of birth

6. Referral/consultation

- Always consult MO/NP

Neonatal resuscitation

Recommend¹

- Ensure neonatal resuscitation equipment + medicines are checked/available for all births
- At least 1 person should be responsible for the care of the baby only
- **Ensure draft free environment of 23–25°** (at least **26° if < 28 weeks** gestation)
- Normothermia + positive pressure ventilation (PPV) are priorities in resuscitation

Background^{1,3}

- This topic is intended for facilities that do not have planned births
- Cyanosis is difficult to recognise in newborns. Colour is an unreliable indicator of oxygenation
- Also see Qld Clinical Guidelines *Neonatal resuscitation + Neonatal stabilisation for retrieval*
<https://www.health.qld.gov.au/qcg/publications#maternity>
- Neonatal resuscitation education programs available at <https://www.health.qld.gov.au/employment/professional-development/online-education>

1. May present with¹

- Newborn immediately after birth ±
 - unresponsive to drying/tactile stimulation
 - poor muscle tone/limp
 - gasping, absent, laboured or poor respiratory effort
 - HR < 100 or absent

2. Immediate management^{1,3}

- Call for help + urgently contact MO/NP
- **Keep warm:**
 - **if < 28–30 weeks/very small baby, put in clear zip lock plastic bag** (up to neck) - without drying¹
 - dry head + put on hat.¹ Put baby on resuscitation trolley with overhead heater if available - head towards clinician
 - **if > 30 weeks, place baby skin to skin on mothers chest:**
 - dry, replace wet towel with warm dry towel + hat on head
- Check:
 - **tone** (flexed/moving limbs)
 - **breathing** (RR 30–60)
 - **HR** 100–160, listen with stethoscope (if breathing, the HR should be > 100 within 1–2 minutes)
- If tone good and HR > 100, immediate intervention not needed³ - go to [Care of the newborn, p. 412](#)
- Suctioning not routine - gently suction mouth only if obvious thick meconium liquor, blood or secretions

If weak/absent responses or not breathing

- Try brisk gentle drying with warm towel to stimulate breathing (or through plastic bag)
- Ensure head and neck supported in neutral position/airway open
- **If HR < 100 AND still not breathing or ineffective respirations (gasps):**
 - place on back - head in neutral/sniffing position ± put 2 cm roll blanket/towel under shoulders
 - support lower jaw and open baby's mouth as needed⁴
 - **start bag/valve/mask ventilation within 1 minute** at 40–60 breaths/minute (room air)^{1,3,4}

- **If airway blocked** by meconium, blood or secretions, gently suction:⁴
 - eg respiratory efforts with no audible air entry to lungs
 - suction mouth/oropharynx first, then nostrils - no more than 5 cm from lips in term baby (measure from mouth to corner of jaw)
 - use size 10–12 F (8 for preterm) suction catheter - only for a few seconds
 - do not exceed 100 mmHg/13 kPa suction pressure
- **Put pulse oximeter sensor** on baby's **right hand or wrist** (pre-ductal) to monitor HR and SpO₂:^{1,3,4}
 - for targeted levels of SpO₂ for 1st 10 minutes after birth see **Newborn life support flowchart**
 - titrate supplemental O₂ accordingly
 - effective ventilation indicated by chest wall movement, improvement in HR and SpO₂

Effective ventilation will almost always be enough to resuscitate the baby

- **If little or no visible chest wall movement, improve ventilation technique:**⁴
 - check face mask fits well (over nose and open mouth), with minimal leak
 - check neck and jaw position
 - occasionally an oropharyngeal airway/LMA may be useful if ≥ 34 weeks or > 2000 g
- **After 30 seconds of ADEQUATE assisted ventilation - if HR < 60 start CHEST COMPRESSIONS:**⁴
 - 3 compressions: 1 breath (90 compressions/minute)
 - increase O₂ to 100% until responding
- **If HR > 60 but < 100 - cease compressions and continue ventilation 40–60 breaths/minute**
 - continue ventilation until infant spontaneously and effectively breathing
- **If HR remains < 60 - MO/NP may order adrenaline (epinephrine) \pm glucose:**
 - umbilical vein is preferred route if skilled, otherwise use **Intraosseous, p. 57**
- Record **Apgar score, p. 412** at 1 and 5 minutes after birth. Then every 5 minutes until HR and breathing are normal

Preterm babies⁵

- Respiratory support will be required for most very preterm babies
- **Temperature** - very premature babies are at \uparrow risk of hypothermia
- **If < 28 – 30 weeks - resuscitate baby in clear polyethylene (plastic) bag/sheet up to the neck** eg zip lock bag, oven bag, NeoWrap® - **not over head**
 - do not dry body, only head before placing in bag + apply pre warmed hat
 - provide tactile stimulation through bag
 - use a radiant warmer if available
 - do not remove the bag during resuscitation
 - keep in place until T checked + other measures in place eg pre warmed incubator
- **Handle gently/skin care**
 - preterms have \uparrow risk of damage to skin and internal organs
 - ensure good infection control eg handwashing
 - if umbilical catheterisation required, use aqueous chlorhexidine. Use sparingly + avoid pooling



Newborn Life Support

At all stages ask: do you need help?

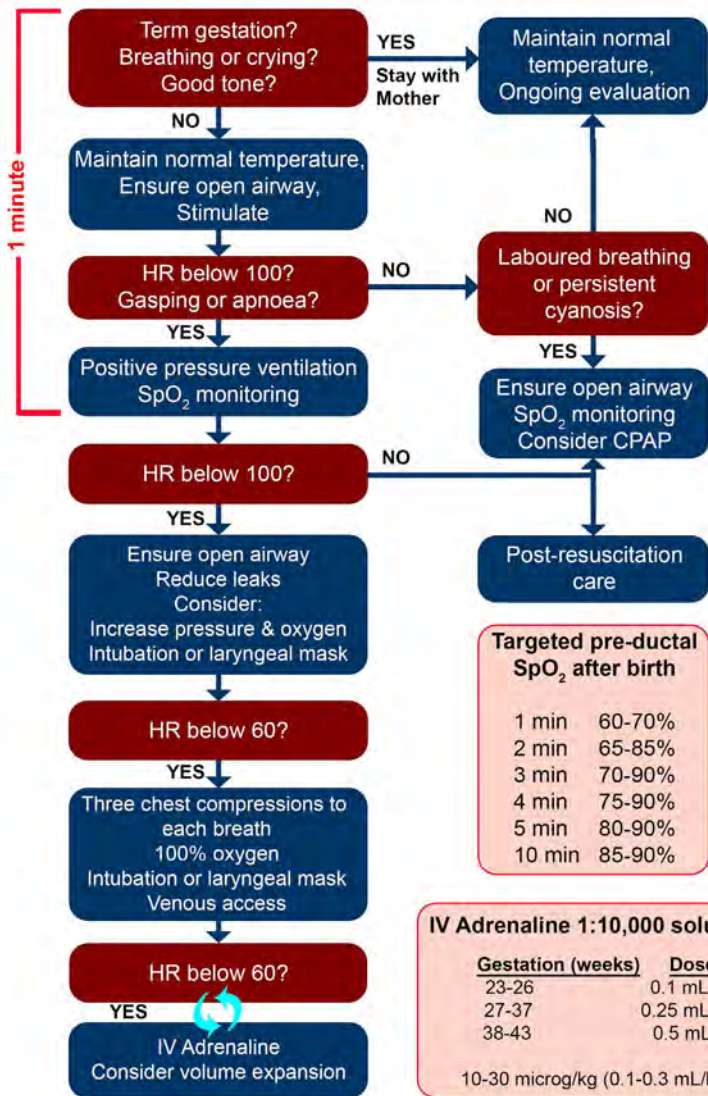

April 2021



NEW ZEALAND Resuscitation Council
WHAKAHAUHORA KOTEAROA

3. Clinical assessment⁷

- Check BGL - is at risk of hypoglycaemia. See [Care of the newborn, p. 412](#) for further management

4. Management⁷

- Prepare for retrieval in consultation with MO/NP/retrieval team
- MO/NP may consider FBC, blood cultures + antibiotics as resuscitation may be a consequence of the onset of sepsis
- Post resuscitation:
 - **keep warm** and maintain T 36.5–37.5
 - closely monitor SpO₂, HR, RR and respiratory effort, tone
 - after 10 minutes of age target SpO₂ is:
 - term babies 92–98%
 - preterm babies 90–95%
- Continue routine [Care of the newborn, p. 412](#) including administration of vitamin K
- Provide support to the mother and family and keep informed - resuscitation of a baby will be distressing for parents

5. Follow up

- As per MO/NP

6. Referral/consultation

- Consult MO/NP on all occasions

HMP Care of the newborn

Recommend

- Skin to skin contact where possible for T, BGL + HR stability and early breastfeeding¹

Background

- It is normal to be cyanotic at birth - pink colouring begins soon after onset of breathing. Persistent blue discolouration in extremities is normal (acrocyanosis)²
- Also see Qld Clinical Guidelines (Neonatal) <https://www.health.qld.gov.au/qcg/publications#maternity>

1. May present with

- Newborn after initial resuscitation

2. Immediate management

- For immediate care of the newborn, go to [Neonatal resuscitation, p. 408](#)

3. Clinical assessment

- **Keep with mother:**
 - continue skin to skin to help maintain T. **Note:** if mother unwell baby can be placed skin to skin on someone else's chest eg partner, family member
- **Do:**³
 - Apgar score at 1 + 5 minutes, then
 - RR, colour, positioning for patent airway - 15 minutely for 2 hours
 - T + HR < 1 hour of birth - aim to maintain T 36.5–37.5
 - brief head to toe examination if skilled³

Apgar score - 5 minute score of 7–10 is normal ⁴			
Component	0	1	2
Colour	Cyanotic or pale	Blue extremities	Completely pink
HR	None	1–99	≥ 100
Response to mild stimulus	No response	Grimace	Cry, cough, or sneeze
Muscle tone	Flaccid	Some movement	Active motion with good flexion
Respiratory effort	None	Weak cry or hypoventilation	Good cry

- Be alert to **Symptoms of unwell baby** could mean infection or hypoglycaemia (see table)^{2,5}
- **Check for problems that might impact baby** in antenatal record, including:^{2,3}
 - risk factors for [Group B Strep, p. 395](#). If present + antibiotics NOT given during labour or within 2 hours of birth **urgently consult MO/NP for antibiotics within 30 minutes**
 - **Risk factors for hypoglycaemia** (see table)
 - medications ± substance use
 - syphilis, HIV, hep B
 - Rh D –ve blood group

4. Management³

- Contact MO/NP early + aim to keep baby pink, warm + BGL normal ≥ 2.6
- **Do:**^{2,3}
 - encourage breastfeeding within 30–60 minutes (or mother's feeding choice)⁵
 - confirm the baby's identification arm AND leg bands with the mother + put them on the baby
 - note first urine and meconium (black stool)
 - bare weigh baby + length + head circumference, after > 1 hour skin to skin, 1st feed + normal T
 - routine care of the baby
- **Give** with parental consent:
 - vitamin K to all babies, including preterm³
 - hep B vaccination.⁶ See [Immunisations, p. 554](#)
 - **note:** if mother is HBsAg +ve, baby must have both HBIG and hep B vaccine on day of birth⁶
- **Monitor closely until evacuated:**⁷
 - assess for ↑ WOB eg ↑ RR, nasal flaring, chest recession, expiratory grunting
 - check colour, skin integrity ie bruises, rash; capillary refill, alert/lethargic, tone + movement
 - vital signs + airway
 - document observations at least hourly:²
 - if become abnormal or ↑ WOB, contact MO/NP urgently + go to [Neonatal resuscitation, p. 408](#)

Unscheduled	Phytomenadione (Vitamin K/Konakion®)			
ATSIHP, IHW and IPAP must consult MO/NP				
MID, RIPRN and RN may proceed				
Form	Strength	Route	Dose	Duration
Injection	2 mg/0.2 mL	IM	≥ 1.5 kg 1 mg < 1.5 kg 0.5 mg	stat As soon as possible after birth
Offer CMI: Recommended for all newborns to prevent vitamin K deficiency bleeding				
Note: Ampoule can be given orally - consult MO/NP - dose is different. IM route preferred				
Management of associated emergency: Consult MO/NP				8

Risk factors for hypoglycaemia ⁵ If any see Management table (next page)	Symptoms of unwell baby/ hypoglycaemia ^{5,7} Urgently consult MO/NP
<ul style="list-style-type: none"> • Preterm OR birth weight < 2500 g or > 4500 g • Mother has diabetes • T < 36 or unstable • Resuscitation at birth • Meconium stained liquor • Inadequate feeding • Mother taking beta blockers or dexamethasone • Family history of metabolic/endocrine disorders 	<ul style="list-style-type: none"> • Poor feeding + tone, lethargy • Tremors/jitteriness, irritability • Weak or high pitched cry • Irregular/rapid breathing, respiratory distress • Apnoea episodes, cyanosis • Seizures, altered LOC • Unexpected need for resuscitation, abdominal distension²

Management of baby at risk of hypoglycaemia⁵

Well baby with risk factors for hypoglycaemia

Heel prick sites



- **Initiate feeding** within 30–60 minutes of birth + continue 3 hourly feeding:
 - if < 35 weeks, discuss with MO/NP need for gavage feed(s)
- **Do BGL** via heel prick:
 - before 2nd feed (not longer than 3 hours of age), and
 - before 3rd feed (not longer than 6 hours of age)
- If **BGL \geq 2.6** - continue BGL before every 2nd feed 3–6 hourly
- If **BGL 1.5–2.5 - check/validate BGL on i-STAT then:**
 - if \geq 35 weeks, give glucose gel 40% 0.5 mL/kg buccally prior to feed. Feed immediately (breast, express + give colostrum, or give formula)
 - if < 35 weeks, urgently consult MO for advice
 - repeat BGL in 30 minutes
- Monitor T, HR, RR, colour, LOC, + tone until evacuation

Unwell baby OR BGL < 1.5 or unrecordable

- **Check/validate BGL on i-STAT urgently.** MO/neonatologist/NP may order:
 - IV/IM/subcut glucagon 200 microg/kg - do not delay
 - IV glucose 10% 1–2 mL bolus (umbilical vein if skilled, or intraosseous)
 - repeat BGL in 30 minutes
- Ongoing management as per MO/neonatologist/NP

Also see Qld Clinical Guideline *Hypoglycaemia - newborn* <https://www.health.qld.gov.au/qcg/publications>

5. Follow up

- Newborn check by midwife/MO/NP within 48 hours

6. Referral/consultation

- Contact MO/NP early
- If Aboriginal and Torres Strait Islander baby refer for BCG vaccine

Emergencies in labour and birth

Cord prolapse

Umbilical cord prolapse/presentation

Recommend^{1,2}

- Cord prolapse is an obstetric emergency. The cord can be compressed, cutting off oxygen to the baby resulting in asphyxia or death

1. May present with^{1,2}

- **Cord prolapse:**
 - cord visible or palpable (smooth pulsating band) in or outside vagina
 - membranes have ruptured
- **Cord presentation:**
 - cord felt in front of presenting part of baby (on vaginal examination)
 - membranes usually intact - if membranes rupture, cord prolapse is inevitable
- ± fetal bradycardia or abnormal FHR - may be first indicator

2. Immediate management^{1,2}

- Call for help (get midwife if on-site) + note time
- Consult MO/NP urgently + urgent evacuation
- Aim is to stop cord compression
- Listen to FHR - check mother's pulse simultaneously to differentiate between the two:
 - if FHR normal (110–160) cord is not compressed
 - keep mother in current position and get urgent advice from MO/NP
 - eg if mother is lying flat and FHR normal, put wedge under right hip to provide gentle lateral tilt

Reducing cord compression

- Position in **knee-chest, face-down position** (see diagram) OR **exaggerated Sims position** - (left-lateral with pillow under right hip) ± lowering head of bed, so head lower than pelvis
- **If positioning does not stop compression, also put two gloved fingers into the vagina:**
 - gently push the presenting part of the baby upwards off the cord - **keep fingers there**
 - avoid putting pressure on cord
 - if the cord is outside of the vagina, attempt to gently replace into the vagina with a dry pad¹
 - minimise handling as can cause vasospasm

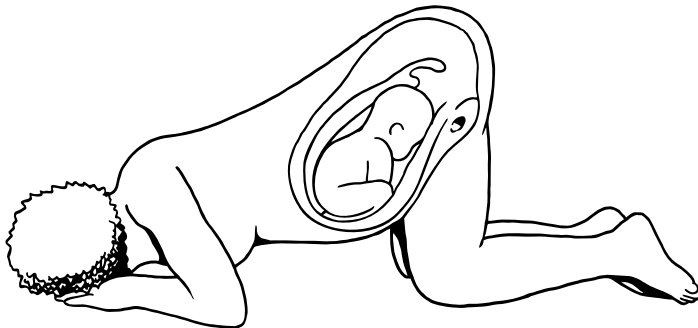

- **MO/NP may advise bladder filling** to maintain elevation of the baby off the cord:¹
 - insert IDC + empty bladder
 - run 500 mL of sodium chloride 0.9% into the bladder using an IV giving set
 - check that the giving set is a good fit with the catheter first, and that fluid can be squeezed into the bladder without leakage
 - clamp the catheter
 - the fingers holding the presenting part may possibly be withdrawn - confirm with MO/NP
 - discuss with MO/NP the timing to release clamp and amount of urine to drain
 - monitor fluid balance
- **Keep woman positioned** knee-chest face-down OR exaggerated Sims' (more practical for transport)
- **Monitor FHR at all times if possible** - alter position of mother in accordance to FHR
- **If FHR not heard** - continue with above measures until an USS can be done

3. Clinical assessment

- Ask about:
 - this presentation, weeks pregnant, pregnancy problems
 - past obstetric/medical history
- Do:
 - vital signs
 - FHR - normal is 110–160
 - palpate contractions
 - assess liquor - clear, meconium stained, bloody

4. Management¹

- Insert IVC eg 14–16 G
- Take bloods - FBC, group and hold
- Nil by mouth
- MO/NP may order/advise:
 - tocolytics to suppress labour. See [Preterm labour, p. 397](#)
 - or, if birth imminent, continue labour and birth baby:
 - if birth, empty bladder first¹ + prepare for [Neonatal resuscitation, p. 408](#)
- In isolated areas, if a woman presents with a cord prolapse, the baby may have already died. However, unless this is certain, it is best to act as above
- Provide emotional support for woman and partner/support person. Keep informed

5. Follow up¹

- Offer ongoing support to woman and family
- Woman may be vulnerable to emotional problems, postnatal depression, post-traumatic stress disorder or fear of further childbirth

6. Referral/consultation

- Consult MO/NP urgently as above
- Consider refer to perinatal mental health support/birth trauma support eg <https://www.birthtrauma.org.au/>

HMP Primary postpartum haemorrhage (PPH)

Recommend

- Close monitoring + rapid response is critical¹
- Visual estimation of blood loss often leads to underestimation. Also consider nature + speed of blood loss + clinical findings¹

Background

- Common causes: **T**issue - retained products/placenta/membranes, **T**one - uterus not contracting, **T**rauma eg of perineum/vagina + **T**hrombin - coagulation abnormalities¹
- Also see Qld Clinical Guideline *Primary postpartum haemorrhage* <https://www.health.qld.gov.au/qcg/publications#maternity>

1. May present with¹

- Bleeding ≥ 500 mL immediately post birth or up to 24 hours later:
 - ≥ 1000 mL is severe
 - ≥ 2500 mL is very severe
- Slow steady trickle of blood after 3rd stage of labour
- Signs of shock, see **Clinical findings**
- Bleeding may look normal if intra-abdominal sources eg ruptured uterus, haematoma²
- **Note:** if > 24 hours post birth + NOT large bleed/shocked, see **Secondary PPH**, p. 429

Clinical findings¹

Blood loss (mL)	Systolic BP	Signs and symptoms	Degree of shock
500–1000	Normal	Palpitations, dizziness, tachycardia	Compensated
1000–1500	Slight ↓	Weakness, sweating, tachycardia	Mild
1500–2000	70–80	Restlessness, pallor, oliguria	Moderate
2000–3000	50–70	Collapse, air hunger, anuria	Severe

Major blood loss can develop rapidly without warning in the absence of haemodynamic compromise

2. Immediate management¹

- DRSABCD
- Send for help
- Contact MO/NP urgently
- Check oxytocin given after birth

If placenta out

- **Massage** fundus (top of uterus) until it is like a hard cricket ball
- Expel clots from uterus if needed - cup fundus with palm of hand, compress uterus between thumb + fingers
- Insert IDC - empty bladder
- IVC x 2 eg 14–16 G¹ (or intraosseous) + take urgent bloods - i-STAT/HemoCue
- **If still bleeding** continue to rub fundus if boggy/not contracting + give:
 - **IV oxytocin** 5 units over 1–2 minutes - **repeat in 5 minutes** if needed
 - **IV fluids** - rapid (warmed if possible) - Hartmann's or sodium chloride 0.9% 1000 mL
 - **oxytocin infusion** 30 units in 500 mL sodium chloride 0.9%, rate 83–167 mL/hour

- MO/NP may order:
 - **ergometrine** + antiemetic. See [Nausea and vomiting, p. 40](#)
 - **misoprostol** - takes 1–2.5 hours to work
 - **tranexamic acid**¹ - give as soon as possible, within 3 hours of PPH
- **If trailing membranes** use sponge holder to remove:
 - without traction, grasp membranes + roll forceps to create a rope
 - use up + down motion + gentle traction to remove
- **If still bleeding excessively** and UTERUS NOT firming - **start BIMANUAL COMPRESSION**
- Check placenta + membranes are complete
- If bimanual compression has been effective MO/NP/retrieval team may consider intrauterine balloon tamponade¹
- If uterus well contracted, placenta + membranes delivered and look intact, and STILL BLEEDING look for **Other causes**¹

Other causes ¹	
Trauma	<ul style="list-style-type: none"> – check perineum, cervix and vagina - check for tears/source of bleeding – apply firm pressure to bleeding areas, or clamps to bleeding vessels until repair
Thrombin	<ul style="list-style-type: none"> – haematuria, petechial conjunctival and mucosa haemorrhage – blood that no longer clots - look on bed or floor – T < 35 – uterine atonia (not contracting)

If placenta NOT out

- Reattempt [Controlled cord traction, p. 405](#)
- Encourage maternal pushing and repositioning
- Insert IDC - empty bladder
- IVC x 2 eg 14–16 G (or intraosseous)
- **If still bleeding:**
 - give IV/M **oxytocin** 10 units
 - give rapid **IV fluids** (warmed if possible) - Hartmann's or sodium chloride 0.9% 1000 mL
 - do vaginal examination to check if placenta remains in uterus. If felt protruding through cervix or lying high in vagina gently attempt to remove
 - if placenta not coming out or incomplete, requires urgent evacuation
 - as a life saving measure MO/NP may advise [Manual removal of the placenta, p. 421](#) in the community
- **If still bleeding excessively** - **start BIMANUAL COMPRESSION**

3. Clinical assessment

- See **Immediate management**

4. Management¹

In all cases

- Lie flat. If hypotensive put feet higher than head by 15–30°
- Give O₂ via face mask at 10–15 L/minute regardless of SpO₂
- Keep warm, aim for T > 36
- Continuously monitor vital signs + rate/volume of bleeding:
 - weigh bloody linen, drapes, bluey's/pinkies if practical (be careful to not underestimate)

- Continue fluid resuscitation on MO/NP orders:
 - IV fluids (up to 2 L crystalloids, up to 1.5 L colloids)
 - monitor fluid balance, aim for urine output \geq 30 mL/hour
 - early blood transfusion if available
- MO/NP may order IM carboprost 250 microg¹
- Take urgent bloods/i-STAT time permitting:
 - CHEM20, FBC, coagulation profile
 - blood gas including calcium + lactate
 - cross match - if no group or cross match available or woman has significant antibodies
 - if intraosseous route used for bloods, make note on pathology form
- Offer analgesia. See [Acute pain, p. 32](#)
- Massive haemorrhage protocol may be activated by MO/NP as per local policy if actively bleeding and ANY of the following:
 - blood loss $>$ 2500 mL
 - anticipated 4 units of blood required in $<$ 4 hours AND haemodynamically unstable
 - evidence of coagulopathy

Bimanual compression¹

- **With 1 hand:**
 - keeping fingers straight and thumb tucked in palmar side of index finger, insert hand into the vagina with palm facing woman’s thigh
 - once fingers meet resistance roll the hand so palm is upward, and curl fingers into a fist
 - place fist in anterior fornix of the vagina and apply upwards pressure
- **With other hand:**
 - locate the top of the uterus (fundus)
 - deeply palpate to put the fingers behind the fundus
 - cupping the fundus, compress it firmly around the fist that is in the vagina
 - keep compressed and evaluate effect



S4	Oxytocin		Extended authority ATSIHP/IHW/IPAP/MID/RIPRN	
ATSIHP, IHW, IPAP and RN must consult MO/NP				
MID and RIPRN may proceed				
Form	Strength	Route	Dose	Duration
Injection	5 units/mL 10 units/mL	IM	10 units	stat
		IV	5 units	stat Inject over 1–2 minutes Repeat after 5 minutes if needed (max. 10 units)
			Infusion 30 units Dilute in 500 mL sodium chloride 0.9%	Infuse at 83–167 mL/hour (5–10 units/hour)
Offer CMI: May cause nausea and vomiting				
Management of associated emergency: Consult MO/NP. See Anaphylaxis, p. 82				1,3,4

S4	Ergometrine			Extended authority
ATSIHP, IHW, IPAP, RIPRN and RN must consult MO/NP				
ATSIHP, IHW and IPAP may not give IV				
MID may proceed				
Form	Strength	Route	Dose	Duration
Injection	500 microg/mL	IM	250 microg	stat May be repeated once after 5 minutes on MO/NP order
		IV	250 microg Dilute to 5 mL with sodium chloride 0.9%	stat Give slowly over 1–2 minutes May repeat once after 2–3 minutes. Further doses on MO/NP order
Offer CMI: May cause nausea and vomiting				
Contraindication: Retained placenta, preeclampsia, eclampsia, severe/persistent sepsis, renal, hepatic or cardiac disease				
Management of associated emergency: Consult MO/NP. See Anaphylaxis, p. 82				1,5,6

S4	Misoprostol			Extended authority
ATSIHP, IHW, IPAP and RN must consult MO/NP				
MID and RIPRN may proceed				
Form	Strength	Route	Dose	Duration
Tablet	200 microg	PR/Subling	800–1000 microg	stat
Offer CMI: May cause nausea, vomiting, diarrhoea, back pain, headache, epigastric pain or vasovagal symptoms eg flushing, shivering				
Note: Monitor cardiovascular status closely as may cause transient BP changes				
Contraindication: Previous caesarean section or major uterine surgery, asthma, COPD - may cause bronchospasm				
Management of associated emergency: Consult MO/NP. See Anaphylaxis, p. 82				1,7

S4	Tranexamic acid			Extended authority
ATSIHP, IHW, MID, RIPRN and RN must consult MO/NP				
Form	Strength	Route	Dose	Duration
Injection	1000 mg/10 mL	IV	1000 mg	stat
			Dilute in 100 mL sodium chloride 0.9%	Infuse over 10 minutes If bleeding persists after 30 minutes a 2nd dose is recommended
Offer CMI: May cause hypotension, dizziness (particularly after rapid administration), thrombosis or visual disturbances				
Contraindication: Active intravascular clotting. Use with caution if predisposition to thrombosis. Reduce dose if renal impairment				
Management of associated emergency: Consult MO. See Anaphylaxis, p. 82				8,9

Aortic compression¹⁰ (if MO advises)

- Aim is to conserve blood by cutting off supply to pelvis via compression:
 - place left fist just above and to the left side of the woman's umbilicus
 - before exerting pressure, feel femoral artery for a pulse using right hand
 - slowly lean over woman to increase pressure over aorta
 - check femoral pulse is now non-palpable - adjust position of fist as needed
 - keep monitoring femoral pulse while aorta is being compressed

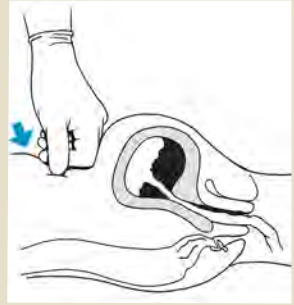
**Manual removal of the placenta** - life saving measure only on MO advice^{11,12}

- MO/NP may order:
 - opioid analgesia + nitrous oxide + O₂ (Entonox®)
 - a single dose of antibiotics - ampicillin or first-generation cephalosporin
- IDC to empty bladder
- Use 1 hand to follow the umbilical cord through the vagina, cervix and lower uterine segment to find the maternal-placental interface
- Keep the uterine fundus in position with the other hand - through the mother's abdomen
- Gently separate the placenta from the uterus with your hand using a side-to-side motion until the placenta has completely separated
- If the opening of the cervix is too small to fit the clinicians hand, MO may order a relaxant eg GTN
- If there is a small area where the placenta is very adherent to the uterus, use your fingers to slowly and persistently attempt to remove
- When placenta removed massage fundus to promote uterine contraction

Uterine inversion¹

- Contact MO urgently who may advise:
 - stop oxytocin infusion, as replacement requires relaxed uterus ±
 - subling GTN 400 microg/spray, IV/subcut terbutaline 250 microg, or IV magnesium sulfate 4 g infused over 5 minutes

5. Follow up

- Support mother baby bonding + help with breastfeeding. Offer debriefing to family + staff as needed

6. Referral/consultation

- Consult MO/NP early as above

Shoulder dystocia

Recommend^{1,2}

- Shoulder dystocia is an obstetric emergency
- **Do NOT:**
 - use downward or excessive pulling of the baby's head - can cause injury to baby
 - do an episiotomy unless your hand is unable to enter the vagina for internal manoeuvres. It will not relieve the bony obstruction
 - apply pressure to the top of the uterus - can cause uterine rupture

1. May present with^{1,2}

- Shoulder does not deliver with normal gentle axial traction of baby
- Difficulty with birth of face and chin
- When head born, it stays tight against vulva, or retracts - turtle-neck sign
- Baby's head fails to restitute (turn)

2. Immediate management^{2,3}

- Call for help + urgently contact MO/NP and get midwife if available. **Stay calm**
- Note **time head born**
- Aim for birth within 5 minutes - if possible
- Ask mother to **stop pushing** - can increase impaction
- Try changing mother's position(s) to help release shoulder
- Go to **STEP 1**

STEP 1 Position legs^{2,3} McRoberts'

- Lie flat, remove pillows, move buttocks to edge of bed
- Bring **thighs to abdomen**. Hyper-flex as far as they can go, so **they lift off the bed**
- Hold legs in place (assistant to do)
- Apply gentle routine axial traction (in line with baby's spine) - same as during a normal birth
- Ask mother to push with next contraction³

If top shoulder NOT released go to STEP 2

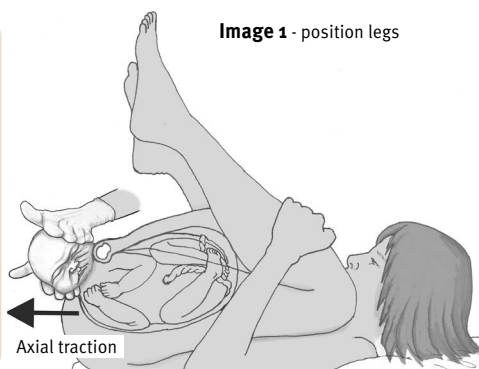

If you are by yourself, go to step 3 - all fours

STEP 2 Apply suprapubic pressure²

- Keep thighs to abdomen as above
- Get assistant to:
 - stand on the side of the baby's back
 - **put hand just above the mother's symphysis pubis**, from side of baby's back (NOT top of uterus)
 - if unsure where back is, choose most likely side (can try other side if not working)
 - **apply pressure in a downward and lateral direction** - continuous or rocking 'CPR-like' motion, compressing baby's shoulder to rotate towards the baby's chest
- **At the same time:**
 - apply gentle routine axial traction to baby's head + ask mother to push with next contraction

If top shoulder NOT released go to STEP 3



STEP 3 Roll onto all fours²

- Assist woman into all fours position, with hips and knees flexed (like a reverse McRoberts' position)
- Apply gentle axial traction to baby's head to deliver the top (posterior) shoulder (buttocks side)
- Ask mother to push with next contraction³

If top shoulder NOT released go to STEP 4

Image 2 - suprapubic pressure

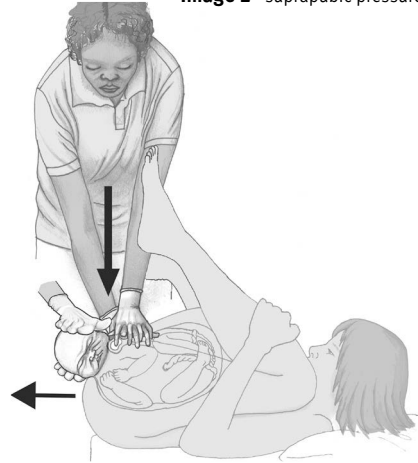
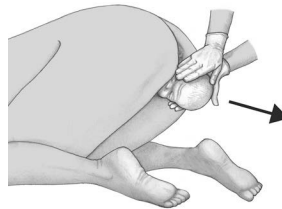

Image 3 - all fours



Images 1–3 adapted from Remote Primary Health Care Manuals. Women's Business Manual (6th ed); 2017. Images 2.10, 2.11 & 2.12 www.remotephmanuals.com.au CC-BY-NC-SA 3.0

STEP 4 Insert whole hand into vagina² (with woman's consent)

- Keep in all fours position OR lie in knees to chest position (McRoberts')
- Insert hand into vagina **in sacral hollow (buttocks side)**:
 - scrunch up hand like trying to fit it into a tin of Pringles® or putting on a tight bracelet (fingers compressed and thumb tucked into palm)
 - will be a tight fit

Try to Deliver posterior arm (woman's buttocks side) **OR Internal rotation**. **Try both if needed**

Option 1 Deliver posterior arm²

Image reproduced with permission of the Queensland Ambulance Service

Option 2 Internal rotation²

Image reproduced with permission of the Queensland Ambulance Service

- Feel across the baby's chest for its arm
- **If arm is FLEXED:**
 - grasp the forearm (with fingers and thumb) and sweep the baby's arm across the baby's face to deliver the arm
 - use action like putting your hand up in class
- Once the arm is delivered, apply gentle traction to deliver the rest of the body
- **If arm is NOT FLEXED (ie straight), flex first by:**
 - locating the baby's elbow, then
 - using your thumb to apply pressure to the antecubital fossa to flex elbow in front of the baby's body
 - then proceed as 'if arm is FLEXED' above

- **Press behind either the front or back of the baby's lowermost (posterior) shoulder:**
 - push to rotate up to 20–30° in the direction of the baby's chest
- **If not working try:**
 - pressing on the other side to move in the opposite direction
 - changing the hand you are using
 - getting assistant to apply suprapubic pressure to help rotation - in the same direction as you

If birth NOT achieved go back to STEP 1

- Continue progressing through each step
- Be guided by MO/NP

3. Clinical assessment

- See **Immediate management**

4. Management³

- Be prepared for [Primary PPH, p. 417](#) - common after shoulder dystocia
- A baby born with shoulder dystocia will require resuscitation. See [Neonatal resuscitation, p. 408](#)
- Once baby born, continue to manage woman as per [Imminent birth, p. 403](#)
- Note which area/shoulder was trapped to assess for damage
- MO/NP will arrange for evacuation to neonatal unit
- Keep mother informed of what is happening
- If outcome of shoulder dystocia results in neonatal injury or death, provide emotional support to mother and partner/family

5. Follow up

- As guided by MO/NP

6. Referral/consultation

- Always consult MO/NP

Breech birth

Recommend

- Manage a preterm breech the same as if at term¹
- Avoid traction/pulling on the baby's trunk. Can cause arms to go around back of neck and complicate the birth²
- Episiotomy not usually needed¹

Background²

- Once buttocks have passed the perineum, significant cord compression is common
- The Burns-Marshall technique (grasping the feet of the baby who has delivered to the nape of the neck and sweeping up in a wide arc to deliver the head) is **not advised**. Can cause overextension

1. May present with²

- Woman in 2nd stage of labour
- Baby's buttocks/feet are presenting

2. Immediate management²

- Call for help + urgently contact MO/NP and get midwife if available. **Stay calm**
- During birth:
 - semi-recumbent or all fours position (consider semi-recumbent position if assistance needed)²
 - make sure baby's back stays opposite to mothers back:
 - if baby's trunk looks like it is rotating to the sacro-posterior position (baby's back to mother's back) controlled rotation may be needed
 - only handle baby over bony prominences
 - keep mothers bladder empty where possible

Keep HANDS OFF as much as possible

- When baby's buttocks are seen at vaginal opening:
 - note time
 - **encourage mother to push** during contractions
 - allow baby to birth by itself
 - keep hands off - do not pull baby
- When umbilicus visible **note time** (avoid handling umbilical cord, can cause vasospasm)
- In most cases the baby will birth spontaneously and you only need to gently support the body as the head is born
- **If buttocks remain at vaginal opening WITHOUT descent:**
 - urgently consult MO/NP for evacuation + caesarian section
- **If spontaneous descent of baby's body to level of umbilicus (at vaginal opening) but legs still extended:**
 - release the legs by applying gentle pressure on the posterior knee towards the baby's abdomen (flex knee) and then laterally (lateral rotation of hip)

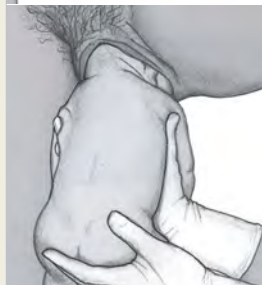

Images from Remote Primary Health Care Manuals, Women's Business Manual (6th ed); 2017. Images 2.23 & 2.24
www.remotephcmanuals.com.au CC-BY-NC-SA 3.0

Signs assistance needed²

- Poor baby condition eg poor colour, tone
- No forward movement of the baby with a uterine contraction and maternal effort (pushing)
- Delay eg due to extended arms/neck:
 - > 3 minutes from birth of umbilicus to head
 - 5 minutes between the birth of the buttocks to head

Assistance

- **If arms do not birth spontaneously**
 - use Løvsett's manoeuvre (below):
 - aim is to bring the posterior shoulder of the baby into the curve of the mothers sacrum, then rotate this posterior shoulder in the direction of the baby's back to anterior and inferior of the mothers symphysis pubis, allowing the release of the arm across the baby's face
 - repeat process on the other shoulder and arm of the baby

Løvsett's maneuver to release arms²

- **Gently hold the baby around the thighs**, placing thumbs on the buttocks and first finger on symphysis pubis (encircling the hips) - **Image 1**
- **Rotate baby** keeping the back anterior until a shoulder is under the mother's symphysis pubis
- **Sweep the arm** (nearest to the symphysis pubis) down across the chest (toward the umbilical cord) and out - **Image 2**
- Following release of the 1st arm:
 - rotate baby 180° keeping back anterior
 - the 2nd arm becomes upper most
 - release this arm as per the first
- **After release of the arms:**¹
 - support baby until nape of neck becomes visible
 - use the weight of the baby to encourage flexion of the head
 - gently support baby as head is birthed

Image 1



Image 2

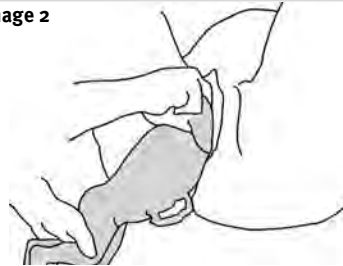

- **If head does not birth spontaneously**²
 - get assistant to apply suprapubic pressure to the mother to assist flexion of the head
 - if head still not birthing, use Mauriceau-Smellie-Veit manoeuvre
 - **do not allow the head to get de-flexed** eg by pulling baby

Mauriceau-Smellie-Veit manoeuvre birth of the head²

- Support baby's body on the under surface of your dominant forearm:
 - place 1st and 2nd fingers of your hand on the cheekbones of the baby (no fingers in mouth)
- With your other hand:
 - apply pressure to the occiput (back of baby's head) with the middle finger
 - place the other fingers on the baby's shoulders to promote flexion of the head (keep the chin on the chest)
- Deliver baby in an arc towards the mother's abdomen
- Ask assistant to apply suprapubic pressure to the mother to aid flexion

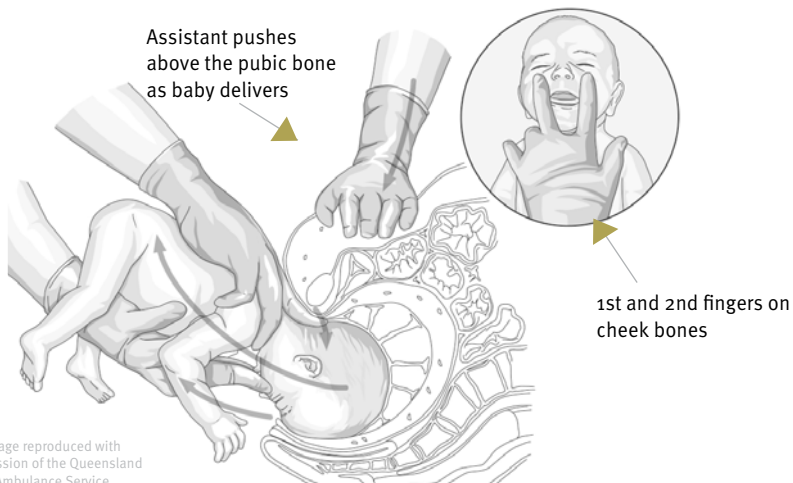
**3. Clinical assessment**

- See **Immediate management**

4. Management

- A baby born via breech may require resuscitation. See [Neonatal resuscitation, p. 408](#)
- Once baby birthed, continue to manage woman as per [Imminent birth, p. 403](#)

5. Follow up

- As guided by MO/NP

6. Referral/consultation

- Always consult MO/NP

Postnatal

HMP Secondary postpartum haemorrhage (PPH)

Recommend

- May present as massive haemorrhage. Start resuscitation, rapid response is critical¹

Background

- Usually occurs as a result of a tear, an infection, or by fragments of the placenta ± membranes, remaining in the uterus + causing an infection or preventing the uterus from contracting^{1,2}

1. May present with

- Vaginal bleeding > 500 mL¹ after 24 hours + up to 12 weeks postpartum²
- ± signs of infection - fever, pelvic pain, uterine tenderness, offensive vaginal discharge
- ± signs of shock:
 - ↓ LOC
 - restlessness
 - cool, clammy skin, sweating
 - mottled or ashen appearance

2. Immediate management¹

- If **large bleed/shock**, treat the same as [Primary PPH, p. 417](#)
- Do vital signs
- Screen for [Sepsis, p. 64](#)

3. Clinical assessment

- If haemodynamically stable, continue as below
- **Ask about:**²
 - bleeding - when did it start, how much, is it heavy and ongoing, colour
 - feeling unwell/well, fever
 - pain/cramping - where, when did it start, severity
 - offensive vaginal discharge
 - any other symptoms - rigors, nausea, vomiting
 - consider other sources of infection - mastitis, UTI³
- **Get obstetric history, including:**^{2,3}
 - parity, labour + birth details - vaginal or caesarean
 - any interventions for immediate bleeding after birth eg misoprostol, blood transfusion²
 - any complications eg manual removal of placenta, prolonged ROM/labour, fever in labour
 - completeness of placenta + membranes¹
- Any relevant medical or family history - bleeding disorder, diabetes, hypertension²
- Estimate total blood loss, previous + ongoing:
 - be mindful of underestimation + keep all pads/linen for weighing
- **Do physical examination, including:**¹
 - blood loss, clots, amount, colour
 - palpate abdomen - assess uterus size, tenderness, any bladder distension²
 - if uterus boggy, rub fundus

- **If skilled**, do sterile speculum examination:¹
 - look for bleeding source, infected tears on vulva/perineum
 - visualise the cervix, any discharge
 - is cervical os open or closed
 - if products of conception protruding, use sponge forceps to remove gently
 - take endocervical swab + vaginal swabs (including episiotomy/tear sites) for MCS, gonorrhoea, chlamydia + trichomonas PCR. See [STI/BBV tests](#), p. 448
- **Do:**¹
 - if > 6 weeks postpartum, do pregnancy test
 - urinalysis + MSU for MCS if signs of infection¹
 - bloods - FBC, clotting profile on i-STAT
 - if T \geq 38 take blood cultures

4. Management

- Consult MO/NP who may order:
 - antibiotics \pm misoprostol⁴
 - evacuation/hospitalisation - where possible keep mother + baby together
 - nil by mouth
 - monitor closely - vital signs + amount/rate of blood loss

5. Follow up

- If not evacuated/hospitalised, advise woman to:
 - be reviewed the next day, or sooner if concerned, or if bleeding restarts/gets heavier
 - see MO/NP at next clinic
- Follow up test results

6. Referral/consultation

- As above

HMP Mastitis or breast abscess

Background

- Also see Qld Clinical Guideline *Establishing breastfeeding* <https://www.health.qld.gov.au/qcg/publications#maternity>

1. May present with^{1,2}

- **Mastitis:**
 - red, tender, hot, swollen, wedge-shaped area of breast
 - $T \geq 38.5$
 - chills, flu-like aching
 - difficulty breastfeeding
- **Breast abscess:**
 - severely swollen, painful lump, oedema in overlying skin

2. Immediate management

- Do vital signs
- Screen for [Sepsis, p. 64](#)

3. Clinical assessment

- **Ask about:**^{2,3}
 - fever, chills, flu-like aching
 - breast pain, tenderness, redness, swelling - when did it start
 - other symptoms eg nausea, vomiting, fatigue
 - age of baby
- **Ask about feeding:**²
 - breastfeeding/other:
 - how often - usual 8–12 times/day
 - feeding from affected breast
 - if expressing - how often
- **Examine breasts.** Any signs of:^{2,3}
 - mastitis/redness/abscess
 - damage to nipples - sore, cracked, bleeding
 - **note:** a blocked milk duct presents as a tender lump in well women
- **Check baby while breastfeeding:**²
 - correct positioning and attachment (if skilled):
 - mouth is opened wide against breast, with nipple and surrounding breast in mouth
 - deep jaw movements, cheeks are not sucked in
 - milk transfer is evident and breast softens during feed
- **Check baby getting enough milk:**¹
 - alert, mostly happy
 - ≥ 6 day wet nappies/24 hours
 - gaining weight:
 - weigh baby bare - check against previous weight, should \uparrow
 - plot on growth chart
 - **note:** if < 1 week of age, for normal input/output see Qld Clinical Guideline *Establishing breastfeeding*, Appendix C

4. Management¹

- **Breast abscess:**
 - consult MO/NP if suspected
 - needs incision and drainage ± evacuation
- **Mastitis:**^{1,2}
 - **frequent and effective milk removal/feeding is most important management**
 - start now - delay may lead to infection/breast abscess
 - encourage to keep breastfeeding
- Offer ibuprofen or paracetamol. See [Acute pain, p. 32](#)
- **Give antibiotics if:**^{1,2,4}
 - acutely unwell with systemic symptoms **OR**
 - symptoms are not improving in 24–48 hours with ↑ milk removal/feeding:
 - flucloxacillin **OR**
 - cefalexin if hypersensitivity to penicillins eg rash **OR**
 - clindamycin if anaphylaxis or immediate reaction to penicillins

Advice to improve milk removal^{1,2}

- Get advice from lactation consultant, midwife or child health nurse
- ↑ feed frequency
- Before feed apply heat - shower, warm cloth, heat pack
- Start feed on affected side - if too painful, start on other side and switch once let-down occurs
- Ensure attachment correct
- Massage during feed from blocked/tender area toward nipple
- Express after feed if required
- Advise rest, fluids and nutrition, comfortable bra, cold packs after feeds

S4	Flucloxacillin			Extended authority	
ATSIHP, IHW, IPAP and RN must consult MO/NP					
MID and RIPRN may proceed					
Form	Strength	Route	Dose	Duration	
Capsule	250 mg 500 mg	Oral	500 mg qid	5–10 days Stop at 5 days if resolved	
Offer CMI: Take on an empty stomach ½ hour before or 2 hours after food. May cause diarrhoea, nausea or thrush. Safe in breastfeeding. May cause loose bowel actions in baby					
Note: Can cause cholestatic hepatitis. If renal impairment seek MO/NP advice					
Contraindication: History of cholestatic hepatitis with dicloxacillin or flucloxacillin. Severe or immediate allergic reaction to a penicillin. Be aware of cross-reactivity between penicillins, cephalosporins and carbapenems					
Management of associated emergency: Consult MO/NP. See Anaphylaxis, p. 82					4,6

S ₄	Cefalexin			Extended authority
ATSIHP, IHW, IPAP and RN must consult MO/NP				
MID and RIPRN may proceed				
Form	Strength	Route	Dose	Duration
Capsule	250 mg 500 mg	Oral	500 mg qid	5–10 days Stop at 5 days if resolved
Offer CMI: May cause rash, diarrhoea, nausea, vomiting, dizziness, headache or thrush. Safe in breastfeeding. May cause loose bowel actions in baby				
Note: If renal impairment seek MO/NP advice				
Contraindication: Severe or immediate allergic reaction to a cephalosporin or a penicillin. Be aware of cross-reactivity between penicillins, cephalosporins and carbapenems				
Management of associated emergency: Consult MO/NP. See Anaphylaxis, p. 82 4,7				

S ₄	Clindamycin			Extended authority
ATSIHP, IHW, IPAP and RN must consult MO/NP				
MID and RIPRN may proceed				
Form	Strength	Route	Dose	Duration
Capsule	150 mg	Oral	450 mg tds	5–10 days Stop at 5 days if resolved
Offer CMI: May cause rash, diarrhoea, nausea, vomiting or abdominal pain. Take with a full glass of water. Can cause severe diarrhoea (colitis) due to <i>C. difficile</i> . Safe in breastfeeding. May cause loose bowel actions in baby				
Contraindication: Allergy to clindamycin or lincomycin				
Management of associated emergency: Consult MO/NP. See Anaphylaxis, p. 82 4,8				

5. Follow up

- Advise to be reviewed daily, or sooner if breastfeeding support needed:
 - check baby is feeding adequately + gaining weight
 - if a well defined area remains hard, red and tender despite management consider breast abscess⁵
 - if no improvement in 24–48 hours consider antibiotics⁴
- If antibiotics given and no improvement consult MO/NP:
 - + consider candidiasis

6. Referral/consultation

- If required, refer to lactation consultant, midwife or child health nurse

Postnatal check

Recommend¹

- Do on day 3, between day 7–14 and 6 weeks after birth. Modify to meet needs of mother and baby
- Mother and baby should be seen as a unit in the first few months
- At 6 weeks do baby check and immunisations. See the *Chronic conditions manual* <https://www.health.qld.gov.au/rrcsu/clinical-manuals/chronic-conditions-manual-ccm> Baby check form <https://www.health.qld.gov.au/rrcsu/resources>

1. May present with

- Mother and baby after birth

2. Immediate management Not applicable

3. Clinical assessment¹

- **Check birth + pregnancy history:**
 - get discharge summary from hospital
 - normal birth or caesarean, gestation, estimated blood loss
 - antenatal problems eg gestational diabetes, anaemia, ↑ BP, preeclampsia
 - pathology results:
 - rubella - if non-immune check MMR vaccine was given after birth
 - STIs needing follow up - mother and baby eg syphilis
- **Check if history of:**
 - RHD, depression, anxiety
- **Ask about:**
 - baby feeding - breastfeeding/other, any concerns
 - urinary symptoms
 - constipation - advise diet, ↑ fluid intake ± gentle laxative³
 - vaginal discharge - colour, amount, any odour⁴
 - perineal pain/stitches
 - caesarean wound - pain/concerns
 - legs/signs of DVT, p. 124
 - alcohol/tobacco, second-hand smoke
 - how is she coping, emotional/other support² +
 - do EPDS between 6–12 weeks post birth www.blackdoginstitute.org.au/docs/CliniciansdownloadableEdinburgh.pdf
 - check risk of domestic and family violence - redo antenatal screening tools if needed
- **Do:**^{2,3}
 - vital signs
 - look for signs of anaemia - pallor, fatigue, breathlessness - check Hb if concerned
 - urinalysis if urinary symptoms
 - offer to check perineum if concerns
 - check caesarean wound
 - if CST due, offer/refer around 6 weeks
 - **note:** abdominal palpation to assess fundus is not needed, unless there are concerns²

4. Management

- Consult MO/NP if:
 - abnormal vaginal discharge/blood loss eg:⁴
 - soaking > 1 pad/1–2 hours
 - amount suddenly ↑ or large clots
 - suddenly changes to bright red
 - smells
 - fever⁴
 - dizzy, weak, sweaty, trouble breathing⁴
 - perineal or caesarean wound looks infected
 - Hb ≤ 110 g/L
- Follow up **Antenatal problems**
- Offer **Postnatal advice** as appropriate

Antenatal problems	Follow up
Hypertension or preeclampsia ⁵	<ul style="list-style-type: none"> • Advise to have MO review at 6 weeks
Syphilis treated in pregnancy (regardless of adequacy of treatment) ⁶	<ul style="list-style-type: none"> • Check baby at every opportunity for signs of syphilis eg rash, hepatomegaly, rhinitis, lymphadenopathy • Baby needs syphilis serology at 3 + 6 months. Also see Qld Clinical Guideline <i>Syphilis in pregnancy</i> https://www.health.qld.gov.au/qcg/publications
Gestational diabetes ⁷	<ul style="list-style-type: none"> • OGTT at 6–12 weeks to screen for persistent diabetes + lifelong screening at least 3 yearly • Early glucose testing in future pregnancies

Postnatal advice²

- Baby's feeding
- Support available eg parent groups
- [Contraception options, p. 438](#)
- After pains, fatigue, sleeping
- Perineal care, pelvic floor exercises
- Resuming sex - as guided by woman's desire and comfort
- Smoking, nutrition, physical activity, alcohol/drugs
- Safe sleeping, SIDS
- Immunisations for baby

5. Follow up

- Follow up as per individual needs

6. Referral/consultation

- As required, refer to midwife, child health nurse, mental health worker, social worker

Page intentionally left blank

Sexual and reproductive health

Contraception

Contraception options

Recommend

- **Only condoms protect against STIs** - encourage use and easy access
- If a woman presents requesting contraception urgently, clarify if she needs emergency contraception after unprotected sex

Key resources

- **True Relationships and Reproductive Health** <https://www.true.org.au/>
 - [contraceptive choices](#)
 - [fact-sheets, handouts](#)
 - education and training for health professionals
- **Family Planning Alliance Australia** <https://www.familyplanningallianceaustralia.org.au/>
 - [contraceptive choices](#), fact sheets, handouts
 - *How effective is my contraceptive method*
- **The UK Facility of Sexual & Reproductive Healthcare (FSRH)** <https://www.fsrh.org/home/>
 - [UK Medical Eligibility Criteria](#) for Contraceptive Use (UK MEC) - guidance on safe prescribing of contraceptives based on medical contraindications¹ <https://www.fsrh.org/ukmec/>
 - [Quick Starting](#) - starting contraception immediately regardless of timing¹
 - [specific population](#) advice eg women > 40 years, young people
 - [switching methods](#) of contraception safely

Contraception options in order of effectiveness (%)²

> 99% Set and forget	Contraceptive implant eg Implanon®	• Lasts 3 years	• Can be removed at any time; immediately reversible • Insertion and removal by trained clinician
	Hormonal IUD eg Mirena®	• Lasts 5 years	
	Copper IUD	• Lasts 5–10 years	
	Vasectomy, tubal ligation	• Permanent	
93–99% Works well if used 'perfectly' every time	Contraceptive injection eg Depo-provera, p. 439	• 12 weekly injections	
	Vaginal ring eg NuvaRing® (not on PBS)	• 3–4 weekly insertion/removal by woman	
	The pill - COCP , p. 440	• Daily pill	
	The mini pill - POP , p. 442		
76–99% Less effective methods	Condoms	Fertility awareness	Diaphragm
	Female condom	Pulling out	

- **Lactational amenorrhoea** is a contraception option for breastfeeding women. It is 98% effective if ALL of the following are met: **1.** Fully breastfeeding (no other food/milk supplements) **2.** < 6 months since birth **3.** Periods have not returned since birth³

HMP Medroxyprogesterone acetate

Depo-provera®, Depo-ralovera®

1. May present with

- Request for 'Depo injection' for contraception

2. Immediate management Not applicable

3. Clinical assessment¹

- Initial assessment and annual review(s) must be done by MO/NP
- **If returned for 12 weekly injection** ask about:
 - bleeding pattern, side effects eg weight gain, mood changes, headache
 - changes in health - angina, heart attack, stroke/TIA, breast cancer, liver disease

4. Management¹

- If > 12 months since MO/NP review **OR** changes in health as above **OR** > 14 weeks since last injection, advise MO/NP review needed
- **If 1st dose**, MO/NP order needed:
 - do pregnancy test first
 - administer during days 1–5 of period (to be immediately effective)
 - if preference is to give today, but woman is at another stage of her period, MO/NP may consider 'Quick Start' method (**note:** off label use): See <https://www.fsrh.org/standards-and-guidance/fsrh-guidelines-and-statements/quick-starting-contraception/>. Effective after 7 days
- **If 12 weekly injection due:**
 - can be given 14 days early or late and still be effective
 - if woman has unwanted side effects, refer to MO/NP clinic:
 - if she chooses to not have the injection, advise to use condoms until reviewed
 - if having frequent and prolonged bleeding:
 - do pregnancy test + **STI/BBV tests, p. 448** and advise to see MO/NP at next clinic
- **If > 14 weeks since last injection** - advise it is **no longer effective**
 - if unprotected sex in the last 5 days offer **Emergency contraception, p. 443** + **STI/BBV tests, p. 448**
 - do pregnancy test. **Note:** an early pregnancy might not show up
 - if pregnancy test –ve (or inconclusive) **consult MO/NP for new order:**
 - if given - advise it will start working in 7 days. Use condoms or do not have sex during this time + advise follow up pregnancy test in 4 weeks - use recall system

S4	Medroxyprogesterone acetate eg Depo-Provera®, Depo-Ralovera®		Extended authority ATSIHP/IHW/RIPRN/SRH	
ATSIHP, IHW and RN must consult MO/NP or give on current (< 12 months) written order				
RIPRN and SRH may proceed if < 12 months since MO/NP initial prescription				
Form	Strength	Route	Dose	Duration
Injection	150 mg/mL	IM (shake first)	150 mg	Once every 12 weeks ± 14 days
Offer CMI: May cause periods to become irregular and spotting may occur initially. After continued use periods may stop completely. Note: give via deep IM injection, do not rub				
Contraindication: Breast cancer, ischaemic heart disease, stroke, advanced liver disease, multiple risk factors for cardiovascular disease eg smoking, diabetes, hypertension, obesity, dyslipidaemia				
Management of associated emergency: Consult MO/NP. See Anaphylaxis, p. 82				

1,2

- Offer fact sheet on depo medroxyprogesterone acetate (DMPA) injections eg <https://www.true.org.au/fact-sheets>

5. Follow up

- Advise/recall for 12 weeks or for next MO/NP clinic if annual review due

6. Referral/consultation

- As above

HMP Combined oral contraceptive pill (COCP)

1. May present with

- Request for supply of the pill (COCP)

2. Immediate management Not applicable

3. Clinical assessment

- Initial assessment and annual review(s) must be done by MO/NP
- **If requesting repeat supply** ask about:¹
 - side effects, changes in bleeding patterns
 - changes in health - angina, heart attack, stroke/TIA, breast cancer, liver disease, DVT/PE, migraine with aura, new headaches¹
 - new medications
 - check BP ± weight

4. Management¹

- If > 12 months since MO/NP review **OR** changes in health as above **OR** has not been taking continuously, advise MO/NP review needed:
 - if this is likely to delay supply, consider phone consult MO/NP as an interim so contraception can continue
- **If starting COCP** ie on MO/NP prescription:
 - start on days 1–5 of period - immediately effective¹
 - if quicker contraception needed, MO/NP may consider ‘Quick Start’ method ie starting at any time in cycle (**note:** off label use):
 - exclude pregnancy first. Effective after 7 days
 - see <https://www.fsrh.org/standards-and-guidance/fsrh-guidelines-and-statements/quick-starting-contraception/>
- Offer fact sheet on COCP eg <https://www.true.org.au/fact-sheets>

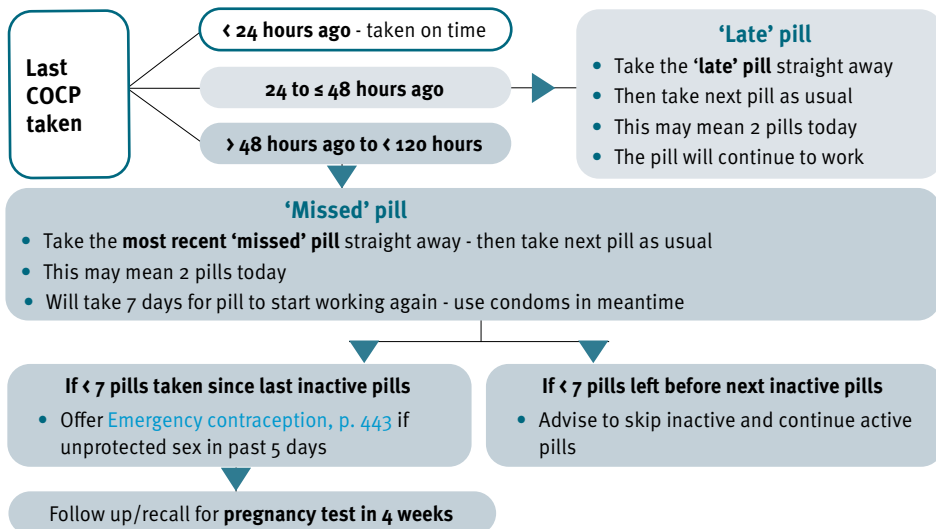
Late or missed pill - COCP¹

- **Combined oral contraceptive pills:**
 - the drug box below contains only one of the many COCP available
 - **it is not intended to infer that this is the only or preferred COCP**, but rather just a reflection of what is usually available in Qld Health rural and remote facilities

S4	Levonorgestrel + ethinylestradiol eg Levlén ED®, Evelyn 150/30 ED®, Eleanor 150/30 ED®	Extended authority ATSIHP/IHW/SRH		
ATSIHP, IHW, RIPRN, RN and SRH may supply as per written order if < 12 months since prescribed by MO/NP. Also see RN supplying, p. 11				
Form	Strength	Route	Dose	Duration
Tablet	150/30 microg	Oral	1 tablet daily	Max. supply not to exceed 4 months OR current prescription, whichever is sooner
Offer CMI: May cause breakthrough bleeding, amenorrhoea, nausea, vomiting, breast enlargement and tenderness, headache, mood changes, changes in libido, ↑ BP, fluid retention, chloasma, acne or thrush. Effectiveness may decrease by some medicines and over-the-counter products eg St John's Wort, vomiting and diarrhoea. Report immediately if severe and sudden pain in chest, severe headache, sudden blurred vision or loss of sight, unexplained tenderness, pain or swelling in one leg				
Contraindication: Past or current history or risk factors for DVT, stroke/TIA, migraine with aura, ischaemic heart disease, breast cancer, severe liver disease. See UK MEC for contraceptive use https://www.fsrh.org/home/				
Management of associated emergency: Consult MO/NP 1,2				

5. Follow up

- Check if [STI/BBV tests, p. 448](#) + annual check by MO/NP due, and offer/advise accordingly

6. Referral/consultation

- As above

HMP Progestogen only pill (POP)

1. May present with

- Request for pill postnatally ± supply of POP

2. Immediate management Not applicable

3. Clinical assessment

- Midwives may initiate 8 weeks supply postnatally, otherwise initial assessment and annual review(s) required by MO/NP
- If requesting repeat supply** ask about:¹
 - side effects (eg headaches, mood changes, weight gain), concerns with bleeding patterns
 - changes in health; new medications

4. Management¹

- Repeat supply:**
 - if changes in health **OR** has not been taking continuously, advise MO/NP review needed:
 - if this is likely to delay supply, consider phone consult MO/NP as an interim so contraception can continue
- Starting the POP in postpartum woman. If:**
 - < 21 days postpartum, start at any time - immediately effective
 - > 21 days and has no period yet - do pregnancy test first. Effective in 48 hours
 - > 21 days and period returned, start on day 1–5 of period
- Starting the POP in other women:¹**
 - start on days 1–5 of period. Is immediately effective
 - if quicker contraception needed, MO/NP may consider 'Quick Start' method ie starting at any time in cycle (**note:** off label use):
 - exclude pregnancy first. Effective after 3 days
 - see <https://www.fsrh.org/standards-and-guidance/fsrh-guidelines-and-statements/quick-starting-contraception/>

Missed pill POP¹

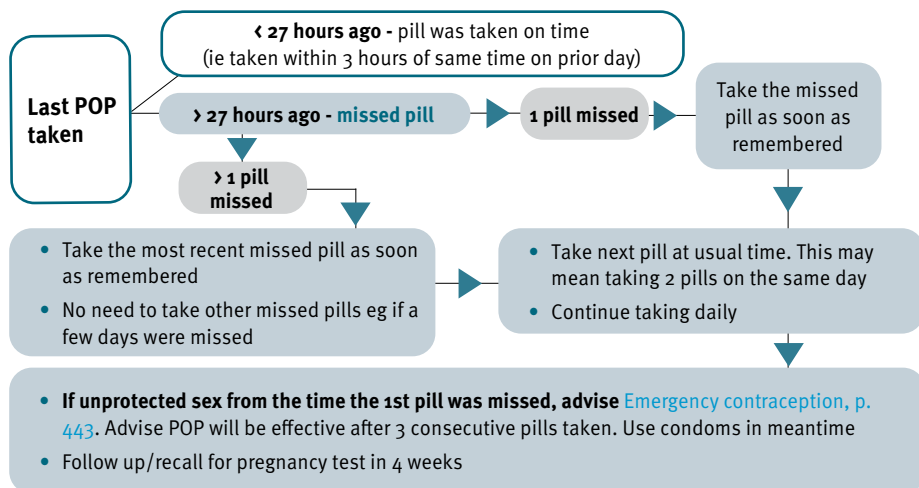

S ₄	Progestogen only pills			Extended authority
ATSIHP, IHW, MID, RIPRN, RN and SRH may supply as per written order if < 12 months since prescribed by MO/NP. Also see RN supplying, p. 11				
MID may initiate supply of levonorgestrel (max. 8 weeks)				
Form	Strength	Route	Dose	Duration
Tablet	Levonorgestrel 30 microg	Oral	1 tablet daily Taken at the same time each day	Max. supply not to exceed 4 months OR current prescription, whichever is sooner
	Norethisterone 350 microg			
Offer CMI: Must be taken ± 3 hours at the same time each day or effect may be reduced. If you vomit within 2 hours of taking, take another pill as soon as possible. May cause amenorrhoea, spotting, irregular period, breast tenderness or acne. All the pills are active ie no sugar pills. Effectiveness may be decreased by some medicines, including over-the-counter products eg St John's Wort				
Contraindication: Breast cancer, ischaemic heart disease, stroke, advanced liver disease				
Management of associated emergency: Consult MO/NP				1,3,4

- Offer fact sheet on POP eg <https://www.true.org.au/fact-sheets>

5. Follow up

- Check if [STI/BBV tests, p. 448](#) + annual check by MO/NP due, and offer/advise accordingly

6. Referral/consultation

- As above

HMP Emergency contraception

1. May present with

- Recent unprotected sex ± request for 'morning after pill'

2. Immediate management Not applicable

3. Clinical assessment¹

- Ask about:
 - time since unprotected sex occurred, last period
 - allergies, medicines
- Do pregnancy test. **Note:** if unprotected sex was < 21 days ago test may be falsely –ve
- Offer [STI/BBV tests, p. 448](#) as appropriate + give condoms
- If concerns around non-consensual sex, report of rape/sexual assault, see [Sexual assault, p. 243](#)

4. Management¹

- Advise no emergency contraceptive options are 100% effective
- Give **levonorgestrel** if up to 72–96 hours (3–4 days) after unprotected sex (can buy over-the-counter):
 - offer advice about ongoing [Contraception options, p. 438](#)
 - consult MO/NP if woman requests ongoing contraception. MO/NP may consider starting today using Quick Start. See <https://www.fsrh.org/standards-and-guidance/fsrh-guidelines-and-statements/quick-starting-contraception/> (**note:** off label use)

- Advise woman of other options as available:
 - **Ulipristal acetate (UPA)** - most effective oral method:
 - use ≤ 120 hours (5 days) after unprotected sex, can buy over-the-counter at some pharmacies
 - **note interaction:** effectiveness decreased with hormonal contraceptives
 - **Copper IUD** - most effective + provides ongoing contraception:
 - use ≤ 120 hours (5 days) after unprotected sex, need skilled clinician to insert

S3	Levonorgestrel			Extended authority ATSIHP/IHW/IPAP
ATSIHP, IHW and IPAP must consult MO/NP				
MID, RIPRN, RN and SRH may proceed				
Form	Strength	Route	Dose	Duration
Tablet	1.5 mg	Oral	1.5 mg	stat Give within 96 hours (4 days), but preferably 72 hours (3 days), of unprotected sex
Offer CMI: May cause nausea, vomiting, breast tenderness, vaginal bleeding or headache. If vomits within 2 hours of taking, needs repeat dose. Period usually occurs within 7 days of expected time. Does not provide ongoing contraception				
Note: Enzyme inducing medicines currently or within prior 4 weeks can reduce effect (eg rifampicin, St John's Wort) - consult MO/NP (copper IUD preferred alternative, or ↑ dose to 3 mg - but evidence of efficacy lacking)				
Contraindication: Severe liver disease				
Management of associated emergency: Consult MO/NP. See Anaphylaxis, p. 82				

1,2

5. Follow up²

- Advise to return in 4 weeks for pregnancy test. Put in recall system

6. Referral/consultation

- Advise to see MO/NP/woman's health nurse/midwife for continuing contraception

Sexually transmitted infections (STIs)

STI and BBV assessment

Recommend

- Opportunistically offer STI/Blood Borne Viruses (BBVs) checks whenever a person comes to clinic¹
- Ensure condoms and lubricant are readily available 24 hours a day
- Confidentiality must be maintained - important in rural and remote areas where clinic staff may be family members/friends of the patient/contacts

Background¹

- STIs and BBVs often have no symptoms until complications occur. If untreated can cause - pelvic inflammatory disease, infertility, miscarriage, epididymo-orchitis, increased risk of HIV acquisition, liver damage or fatality (eg congenital syphilis)
- **In remote Aboriginal and Torres Strait Islander communities, there is/are:**^{1,2}
 - an ongoing outbreak of syphilis
 - high rates of chlamydia, gonorrhoea, trichomonas and hep B
 - + untreated STIs make this group potentially vulnerable to HIV
- **Resources:**
 - Qld Health <https://www.health.qld.gov.au/clinical-practice/guidelines-procedures/sex-health>
 - ASHM <https://www.ashm.org.au/resources/sexual-health-resources-list/> including *STI management guidelines for primary care*
 - Aboriginal and Torres Strait Islander - *Young, deadly, free* <https://youngdeadlyfree.org.au>
 - True relationships and reproductive health <https://www.true.org.au/>

Important principles of treating STI/BBVs¹

- If follow up unlikely, treat symptomatic cases at first presentation (presumptive treatment), without waiting for pathology results
- If positive STI/BBV, do contact tracing + test sex partners (+ treat if needed). Consider treating ongoing partners at the same time to reduce risk of reinfection (eg if they present with patient)
- If someone tests positive for an STI/BBV, offer testing for other STIs/BBV if not already done
- Consider PID, p. 462 in sexually active women/person with a uterus with new onset abdominal pain (can be mild), particularly if < 25 years of age

1. May present with¹

- Sexually active + for screening/opportunistic check
- Symptoms of an STI eg:
 - vaginal or penile discharge
 - pain or burning passing urine
 - genital sores, rash, itching in genital/perianal area
 - low abdominal pain (females/person with uterus), testicular pain, or pain with sex
 - abnormal vaginal/rectal bleeding
- Symptoms of a BBV eg jaundice/abnormal LFTs (hepatitis), or as per HIV, p. 476

2. Immediate management Not applicable

3. Clinical assessment¹

- If asymptomatic, check table below for recommended check-ups (use history as needed to guide):
 - may vary depending on prevalence of STIs - check local guidelines

Asymptomatic check-up^{1,3,5}

Who ¹	When to offer ¹	What to offer ¹
<ul style="list-style-type: none"> • Requests an STI check • Is at ↑ risk of STIs eg new sexual partner • Has a known exposure to any STI or history of STI within past 12 months • Is a partner of person at increased risk of STIs 	This presentation	<ul style="list-style-type: none"> – chlamydia, gonorrhoea – trichomonas (females) – syphilis, HIV* – hep B (if not vaccinated)[#] – hep C* only if at risk
<ul style="list-style-type: none"> • 16–29 years old^{*,4} 	At least annually	
Aboriginal and Torres Strait Islander people^{1,3}		
<ul style="list-style-type: none"> • 15–35 years old[†] 	6 monthly	<ul style="list-style-type: none"> – chlamydia, gonorrhoea – trichomonas (males + females) – syphilis, HIV* – hep B (if not vaccinated)[#] – hep C* only if at risk
<ul style="list-style-type: none"> • People at increased risk of STIs[†] 	3–6 monthly	
<ul style="list-style-type: none"> • > 35 years old and a new partner 	1–2 yearly + as needed	
<ul style="list-style-type: none"> • Pregnant • + refer to Qld Clinical Guideline <i>Syphilis in pregnancy</i> https://www.health.qld.gov.au/qcg/publications 	20 weeks, 34–36 weeks, birth + 6 weeks after birth	<ul style="list-style-type: none"> – syphilis - in addition to routine antenatal syphilis (+ other antenatal STI) tests
Other populations & situations¹		
<ul style="list-style-type: none"> • Men who have sex with men (MSM)⁵ Also see <i>STIGMA Guidelines</i> https://stipu.nswgov.au/stigma/ 	3 monthly, or at least annually if in monogamous relationship	<ul style="list-style-type: none"> – chlamydia, gonorrhoea, syphilis, HIV* – hep A & B (if not vaccinated)[#] – hep C annually if at risk
<ul style="list-style-type: none"> • Refugees and migrants to Australia • People living with HIV • People in custodial settings • Sister-girls, brother-boys, trans + gender diverse • Sex workers • People who use drugs • Adult sexual assault 		<ul style="list-style-type: none"> • Increased screening may be recommended depending on individual risk factors • Refer to Australian STI management guidelines: – http://sti.guidelines.org.au/ • Or contact your local sexual health team for advice
<ul style="list-style-type: none"> • Pregnant 		<ul style="list-style-type: none"> • See Antenatal care, p. 364
<p>‡Or from age of first sexual contact:</p> <ul style="list-style-type: none"> – if < 16 see <i>Guide to offering STI testing for people aged less than 16 years attending clinical services</i> https://www.health.qld.gov.au/clinical-practice/guidelines-procedures/sex-health/guidelines or local policy if outside Qld <p>†At increased risk if - ≥ 1 new partners in last 12 months, > 1 prior STI(s), substance use</p> <p>#Do not need testing if vaccinated or chronically infected. Offer vaccination if not vaccinated</p> <p>*Repeat tests for HIV and syphilis if exposed within 12 weeks. Repeat test for hep C if exposed within 6 months (window periods)</p>		

Get history¹

- May not need history if routine asymptomatic screening
- **As appropriate, get a sexual history and assess STI risk:**
 - gender identification and pronouns that the patient identifies with
 - last STI check (when), results
 - previous STI diagnosed, or thought may have had an STI
 - last time had sex
 - new sexual partner(s)
 - sex without condoms/condom broken
 - sex with men, women, both
 - nature of sex - oral, vaginal, anal
 - pregnant/could be pregnant, reproductive history, contraception
- **Assess hep C risk:**¹
 - history of injecting drug use, current HIV pre-exposure prophylaxis (PrEP) use, anal sex with a partner with hep C virus (HCV) infection, incarceration, non-professional tattoos or body piercings, or receipt of organs or blood products before 1990
- **Ask about symptoms:**¹
 - dysuria; penile/vaginal discharge - colour/odour/amount
 - itch
 - lumps, sores or skin splits on genitals - may have gone away
 - tender/swollen testes
 - pain with sex
 - low abdominal pain in female/person with a uterus
 - bleeding/spotting after sex or between periods
 - enlarged lymph nodes in groin
 - rash/sore on another part of body eg hands/feet
 - patchy hair loss eg part of eyebrow
 - anorectal symptoms - discharge, irritation, painful bowel motions, disturbed bowel function¹

Do examination¹

- **Not needed if asymptomatic screening**
- If has symptoms but does not want examination, still do STI/BBV tests (self collected swabs/urine)
- Do vital signs
- Use history to guide examination. As appropriate, check:
 - if dysuria, get first catch urine (FCU) + MSU. If nitrites or leucocytes on urinalysis get MSU for MCS (in addition to FCU for STIs)
 - rash, lymph nodes - swelling/tenderness
 - genitalia/perianal area - any rashes, lumps, ulcers, skin splits (take swab(s) if needed)
 - women/person with vagina/uterus:
 - abdomen for tenderness
 - consider pregnancy test
 - speculum examination if practitioner experienced and patient consents:
 - cervicitis (cervix easily bleeds ± yellow discharge at os), sores
 - bi-manual examination for tenderness and masses
 - take swabs at same time + Cervical Screening Test (CST) if due
- If anorectal symptoms - if possible, examine for ulcers and discharge (+ take swabs concurrently). If STI likely, treat today, but also refer to next MO/NP clinic - other causes need to be investigated

Do STI/BBV tests

- See STI/BBV pathology (below) to guide specimen collection/what to collect:
 - ensure consent ie type of test, reason for test, potential implications of not being tested
 - encourage patient to self collect swabs/urine
 - do tests appropriate to type of sexual contact ie oral, anal, vaginal (except if m. genitalium - do not do throat swabs as pharyngeal infection uncommon)²

STI/BBV pathology

If no symptoms eg asymptomatic check-up

First catch urine (FCU)

- Chlamydia & gonorrhoea PCR*
- Trichomonas PCR (all females; only Aboriginal and Torres Strait Islander males)

OR

Self collected vaginal swabs

- 1 x chlamydia & gonorrhoea PCR
- 1 x trichomonas PCR

Bloods - 2 x serum gel tubes

- syphilis serology
- HIV - HIV Ag/Ab
- hep B - HBsAg, Anti-HBs, Anti-HBc (if not vaccinated or chronically infected)
- hep C - HCV Ab (if risk + no prior history of hep C)^Ω

*In MSM also get anal and pharyngeal swabs for chlamydia and gonorrhoea PCR + MCS#

If symptoms of an STI eg discharge, dysuria, pelvic pain

Self collected vaginal or penile swabs

- 1 x chlamydia & gonorrhoea PCR*
- 1 x trichomonas PCR (all females; only Aboriginal and Torres Strait Islander males)
- 1 x m. genitalium PCR (all males; females only if cervicitis or pelvic pain present)
- 1 x MCS charcoal swab plus slide[#]

OR

First catch urine (FCU)

If no penile discharge/prefers not to do swabs

- Chlamydia & gonorrhoea PCR*
- Trichomonas PCR (all females; only Aboriginal and Torres Strait Islander males)
- M. genitalium PCR (all males; females only if cervicitis or pelvic pain present)

Bloods

- As per 'if no symptoms' above

AND

If genital sore

- 1 x dry swab for:
 - herpes + syphilis PCR
- Also advise Qld Syphilis Surveillance Service
 - ① 1800 032 238 or syphilis register if outside Qld

*In MSM also get anal and pharyngeal swabs for chlamydia and gonorrhoea PCR + MCS#

Note: female (or person with vagina); male (or person with penis)

Ω If hep C (HCV) positive, it can indicate current or past infection. If positive, test for HCV RNA to detect active infection or re-infection

MCS is for surveillance of antimicrobial resistance of gonorrhoea¹

Note: PCR is a NAAT test (nucleic acid amplification). 'First catch urine' also called 'first pass urine'

How to collect swabs/urine¹ eg self collected by patient

FCU (First catch urine)	PCR	• Any time of day. Start passing urine into the urine jar (catch the first part of the urine stream). Need about 20 mL or 1/3 standard urine jar. Then pass rest of urine into toilet
Throat swab		• Gently wipe swab over tonsils and uvula (punching bag)
Penile swab		• Only do if frank discharge. Milk penis to express discharge
Vaginal swab		• Insert the swab into the vagina like a tampon, twirl and then remove and place into the transport tube
Rectal swab		• Insert swab into the anal canal 2–4 cm, twirl and then remove and place into the transport tube
Genital sore swab		• Clean the lesion with water or sodium chloride 0.9%. Roll swab firmly around the edge and across the lesion, place into the transport tube. Ideally clinician should examine and take swab(s)
Charcoal swab + slide	MCS	• Take swab as described above, roll onto glass slide, then insert swab into charcoal transport tube. Send both to pathology
Handout on chlamydia and gonorrhoea 'self collection' https://www.health.qld.gov.au/clinical-practice/guidelines-procedures/sex-health/guidelines All specimens stored in fridge + transported cold		



Gel blood tube



Urine jar/tube for FCU



Dry swab for PCR

Charcoal swab +
slide for MCS

4. Management¹

- If **symptoms of an STI, confirmed STI**, or **sexual contact** of someone with symptoms or positive pathology for an STI/BBV:
 - do **STI/BBV tests**, p. 448 if not already done
 - go to **STI/BBV flowchart**, p. 451 to guide further management
- Ask about sexual contacts and start **Contact tracing**, p. 450 if:
 - confirmed STI/BBV (on pathology) **OR** if person has symptoms of syphilis (pathology not back)
 - see **STI/BBV flowchart**, p. 451 and specific topic(s) for advice on how far back to trace

In all cases:

- Offer condoms and advice/fact sheet(s) about how to use + about STI/BBVs as relevant eg:
 - transmission, symptoms, complications of untreated STIs/BBVs
 - safe sex practices/risk minimisation, regular screening
 - reiterate that only condoms or abstaining from sex protect against STIs
- Offer advice about **Contraception options**, p. 438 + offer/refer for CST if due

Contact tracing/partner notification^{1,6}

1. Advise reasons for contact tracing

- Essential to avoid reinfection (from untreated partner) and to interrupt ongoing transmission of STI/BBVs
- Partner may be unaware of infection and be at risk of serious complications if not tested + treated

2. Identify who needs to be notified + discuss that contact tracing can be done anonymously

- Refer to relevant STI topic to determine how far back to trace ie likely duration of infection
- Ask about sexual contacts during that time:
 - record in patient with STI/BBV (index) medical record that *contacts obtained* - do not record contacts name(s)
 - write in the contact(s) medical record(s) that they have been identified as a contact and need testing for STI/BBVs (do not record patient's name in contact(s) medical record)
 - if a clinic register/similar is used, ensure the index case is NOT connected to the contact(s) and vice versa

3. Contact sex partners + advise need testing ± treating for STI/BBVs

- Patient may choose to tell their contact(s) themselves, or may want the clinic staff to do this
- 3 attempts by telephone or home visits should be made and documented, UNLESS syphilis or HIV where further attempts at contact tracing needed - seek specialist advice as needed
- If a contact is outside your health centre's area, notify the appropriate contact tracing support officer so they can follow up

Resources

- *Australasian contact tracing guidelines* <http://contacttracing.ashm.org.au/>
- Qld support <https://www.health.qld.gov.au/clinical-practice/guidelines-procedures/sex-health/contact-tracing>
- If outside Qld, contact your local sexual health/contact tracing service

5. Follow up¹

- If you have taken/ordered pathology:
 - advise when and how person will get their results
 - ensure you follow up results - advise patient, treat + start contact tracing as needed
- Repeat tests if negative + patient exposed in window period if:
 - hep C - exposure ≤ 6 months
 - HIV and syphilis - exposure ≤ 12 weeks
- If treated for an STI advise to be reviewed in:
 - **1 week** to confirm taking tablets (as needed), see if symptoms going, give pathology results + ensure contacts have been advised to get tested (as indicated)
 - **3 months** to retest for STIs to detect re-infection (common)
 - + as needed, as per each STI topic
- Activate reminders for testing as needed

6. Referral/consultation

- As appropriate eg for advice about contraception, CST, other men's or women's health

STI/BBV flowchart

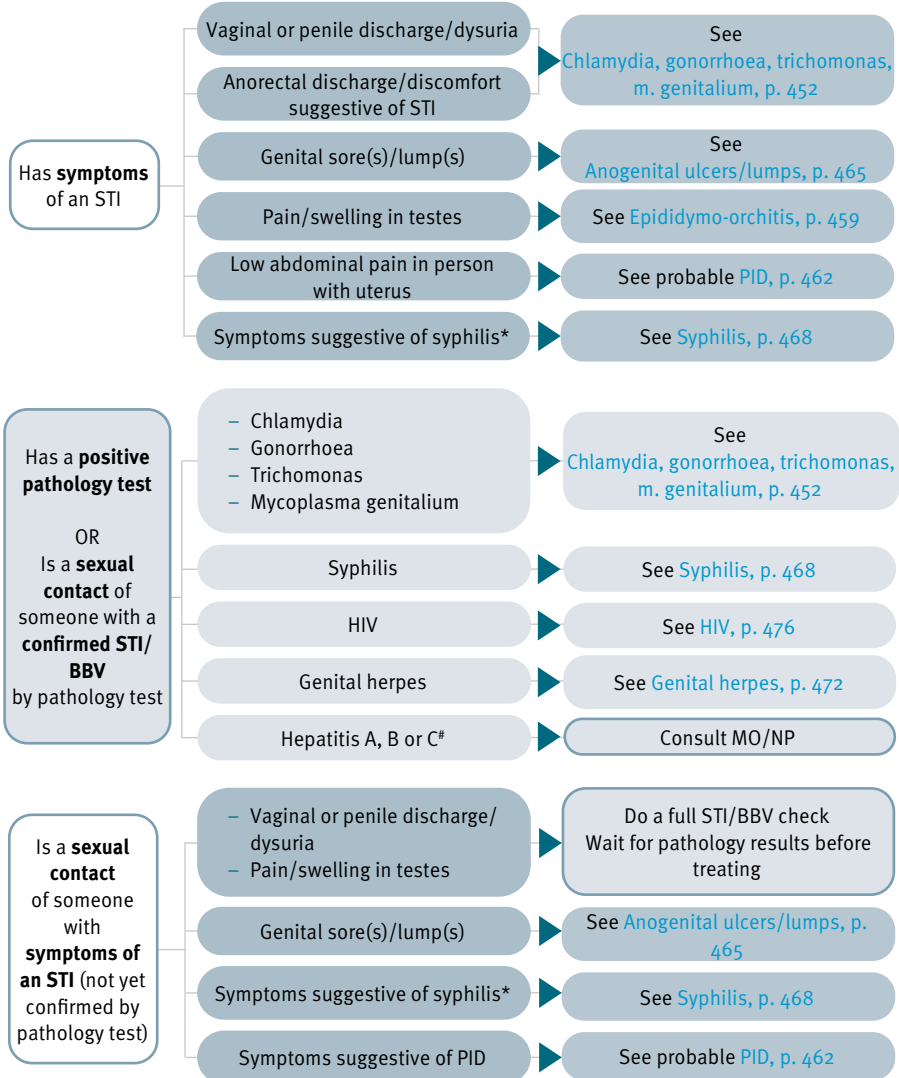

***Syphilis symptoms** - genital ulcer or sore (can also be on anal skin, cervix or mouth) ± multiple warty growths in genital area (condylomata lata) ± rash on trunk or just hands and feet.* See *Syphilis*, p. 468

- **#Hepatitis**

- **hep A** - uncommon in Australia. People at higher risk of infection include: MSM, travellers to countries where hep A prevalent⁸
- **hep B** - see the *Chronic conditions manual* <https://www.health.qld.gov.au/rccsu/clinical-manuals/chronic-conditions-manual-cm> for interpretation of tests and management
- **hep C** - see <https://www.hepcguidelines.org.au/>

- Also see *Decision making tools* for Hep B and Hep C <https://www.ashm.org.au/resources/>

HMP Chlamydia, gonorrhoea, trichomonas, m. genitalium - adult

Vaginal discharge, penile discharge

Background¹

- Often there are no symptoms
- The most likely cause of penile discharge/dysuria is an STI
- Vaginal discharge - cause can be difficult to diagnose on clinical examination alone. Normal physiological discharge is white/clear, non offensive, varying with menstrual cycle
- Trichomonas may persist in women for years and in men for up to 4 months

1. May present with¹

- Positive pathology result
- Sexual contact of someone with positive pathology result or symptoms suggesting an STI
- If symptoms, may include:
 - discharge - penile/vaginal
 - dysuria
 - abnormal bleeding (spotting) after sex or between periods (women)
 - vulval itch/soreness
 - anorectal symptoms - discharge, irritation, painful defecation, disturbed bowel function
- Occasionally gonorrhoea may present acutely ill with single or multiple painful/inflamed joints - (disseminated gonococcal infection)

2. Immediate management Not applicable

3. Clinical assessment¹

- Get history and offer relevant examination as per [STI/BBV assessment, p. 445](#)
- Consider differential diagnoses eg if:
 - low abdominal pain in female/person with uterus, [PID, p. 462](#)
 - sore/swollen testes, [Epididymo-orchitis, p. 459](#)
 - thick, white, non offensive vaginal discharge, [Vaginal thrush, p. 458](#)

4. Management¹

- If current partner (of patient with symptoms/STI) presents at same time, consider treating concurrently
- **If has symptoms:**
 - do [STI/BBV tests, p. 448](#) and treat if indicated on pathology results
 - if follow up unlikely eg in remote area, treat now (without waiting for pathology results)
- **If has a positive pathology result:**
 - treat now + do full [STI/BBV tests, p. 448](#) if not completed already
 - start [Contact tracing, p. 450](#)

Contact tracing/partner notification - how far to trace back, test ± treat^{1,2}

Chlamydia	• 6 months
Gonorrhoea	• Minimum of 2 months (or 2 months prior to onset of symptoms if present)
Trichomonas	• Current partner(s) only ²
M. Genitalium	• Current partner(s) only ²

- **If a sexual contact of person with a positive pathology result:**
 - do [STI/BBV tests, p. 448](#) and wait for results before treating
 - if follow up unlikely, treat now (see below) for the infection(s) they have been in contact with (without waiting for pathology results)
- **If a sexual contact of person with symptoms:**
 - do [STI/BBV tests, p. 448](#)
 - if has symptoms, treat now (see below)
 - if no symptoms, wait for pathology results before treating (or if they presented with patient, consider treating at the same time)

Treatment guide¹ if not allergic. Ideally, watch person take single dose medicines

Symptoms ¹	Treat for	Treat with
Vaginal discharge Penile discharge/ dysuria	<ul style="list-style-type: none"> • Gonorrhoea, Chlamydia and Trichomonas 	<ul style="list-style-type: none"> • Ceftriaxone 500 mg (see note) AND • Azithromycin 1 g* AND • Metronidazole 2 g
Anorectal discharge/pain suggestive of STI	<ul style="list-style-type: none"> • Gonorrhoea and Chlamydia • + if pain, herpes simplex virus 	<ul style="list-style-type: none"> • Ceftriaxone 500 mg (see note) AND • Doxycycline 100 mg bd for 21 days AND • If pain, see Genital herpes, p. 472 for treatment (+ consider possible Syphilis, p. 468)
<ul style="list-style-type: none"> • Note: if area has high penicillin susceptibility to gonorrhoea (as advised by local sexual health specialist or AMS program), replace ceftriaxone with amoxicillin 3 g + probenecid 1 g 		
Pathology results		
Gonorrhoea		<ul style="list-style-type: none"> • Ceftriaxone 500 mg (see note) AND • Azithromycin 1 g OR if pharyngeal infection 2g*
<ul style="list-style-type: none"> • Note: if area has high penicillin susceptibility to gonorrhoea (as advised by local sexual health specialist or AMS program), replace ceftriaxone with amoxicillin 3 g + probenecid 1 g 		
Chlamydia		<ul style="list-style-type: none"> • Doxycycline 100 mg bd for 7 days (preferred) OR • Azithromycin 1 g (if concerns about adherence or if pregnant)
		<ul style="list-style-type: none"> • If anorectal infection: <ul style="list-style-type: none"> – doxycycline 100 mg bd for 7 days (no symptoms) or 21 days (symptoms) OR – azithromycin 1 g + repeat dose in 12–24 hours
Trichomonas		<ul style="list-style-type: none"> • Metronidazole 2 g
Mycoplasma genitalium#		<ul style="list-style-type: none"> • Doxycycline 100 mg bd for 7 days followed by • Azithromycin 1 g on day 8, then 500 mg daily for 3 days

#Treatment for m. genitalium can be complex. Doxycycline is ineffective in 2/3 of infections, but will lower bacterial load in most cases. Cure is likely if azithromycin is also given from day 8. Get advice from local Sexual Health/Public Health Unit if treatment does not work¹

*If treated for gonorrhoea presumptively, then pathology is positive for pharyngeal infection, no need to give extra gram of azithromycin¹ - test of cure should still be done

In all cases

- Advise no sexual activity:¹
 - for 7 days after treatment, or if m. genitalium 'tested for cure' (14–21 days after treatment) +
 - until pathology results available +
 - with partners - current + from prior 6 months (chlamydia) or 2 months (gonorrhoea) until the partners have been tested ± treated if needed
- Use condoms
- Will need **Follow up** check(s) - advise when and why
- Offer advice/fact sheet(s) about STI/BBVs

S4		Ceftriaxone		Extended authority ATSIHP/IHW/IPAP/MID/RIPRN/SRH	
ATSIHP, IHW, IPAP and RN must consult MO/NP					
MID, RIPRN and SRH may proceed					
Form	Strength	Route		Dose	Duration
Injection	1 g	IM		500 mg (2 mL)	stat
		Reconstitute with lidocaine (lignocaine) 1% 3.5 mL to make 1 g/4 mL			Give by deep injection into gluteal muscle
Offer CMI: May cause nausea, diarrhoea, rash, headache or dizziness					
Note: If renal impairment seek MO/NP advice					
Contraindication: Severe or immediate allergic reaction to a cephalosporins or a penicillin. Be aware of cross-reactivity between penicillins, cephalosporins and carbapenems					
Management of associated emergency: Consult MO/NP. See Anaphylaxis, p. 82 1,3					

S4		Azithromycin		Extended authority ATSIHP/IHW/IPAP/MID/RIPRN/SRH		
ATSIHP, IHW, IPAP and RN must consult MO/NP						
MID, RIPRN and SRH may proceed						
Form	Strength	Route	Dose	Duration		
Tablet	500 mg	Oral	1 g (2 g if pharyngeal gonorrhoea)	stat		
			M. genitalium			
			1 g 500 mg daily	stat on day 8 For 3 days after day 8 stat dose		
Offer CMI: May cause rash, diarrhoea, nausea, abdominal cramps or thrush						
Management of associated emergency: Consult MO/NP. See Anaphylaxis, p. 82 1,4						

S4		Metronidazole		Extended authority ATSIHP/IHW/IPAP/MID/RIPRN/SRH	
ATSIHP, IHW, IPAP and RN must consult MO/NP					
MID, RIPRN and SRH may proceed					
Form	Strength	Route	Dose	Duration	
Tablet	200 mg, 400 mg	Oral	2 g	stat	
Offer CMI: Avoid alcohol for 24 hours after taking. Take with food to reduce stomach upset. May cause nausea, anorexia, abdominal pain, vomiting, diarrhoea, metallic taste, dizziness or headache					
Management of associated emergency: Consult MO/NP. See Anaphylaxis, p. 82 1,5					

S ₄	Doxycycline			Extended authority
ATSIHP, IHW, IPAP and RN must consult MO/NP				
MID, RIPRN and SRH may proceed				
Form	Strength	Route	Dose	Duration
Tablet	50 mg 100 mg	Oral	100 mg bd	Chlamydia OR m. genitalium 7 days
				Anorectal chlamydia no symptoms - 7 days symptoms - 21 days
Offer CMI: Take with food or milk to reduce stomach upset. May cause nausea, vomiting, diarrhoea, epigastric burning, tooth discolouration or photosensitivity. Take with a large glass of water. Do not lie down for an hour after taking. Do not take iron, calcium, zinc or antacids within 2 hours. Avoid sun exposure				
Pregnancy: Safe in the first 18 weeks				
Contraindication: Serious allergy to tetracyclines. Taking oral retinoids. After 18 weeks of pregnancy				
Management of associated emergency: Consult MO/NP. See Anaphylaxis, p. 82 1,6				

S ₄	Amoxicillin			Extended authority
ATSIHP, IHW, IPAP and RN must consult MO/NP				
RIPRN may proceed				
Form	Strength	Route	Dose	Duration
Capsule	1 g, 500 mg	Oral	3 g	stat
Provide CMI: May cause rash, diarrhoea, nausea or thrush				
Note: Given for gonorrhoea only if area has high penicillin susceptibility (as advised by local sexual health specialist or AMS program)				
Contraindication: Severe or immediate allergic reaction to a penicillin. Be aware of cross-reactivity between penicillins, cephalosporins and carbapenems				
Management of associated emergency: Consult MO/NP. See Anaphylaxis, p. 82 1,7				

S ₄	Probenecid			Extended authority
ATSIHP, IHW, IPAP and RN must consult MO/NP				
RIPRN may proceed				
Form	Strength	Route	Dose	Duration
Tablet	500 mg	Oral	1 g	stat
Provide CMI: May cause rash, nausea or vomiting. May be taken with food to reduce upset stomach				
Pregnancy: Seek MO/NP advice				
Contraindication: Blood dyscrasias, uric acid kidney stones				
Management of associated emergency: Consult MO/NP. See Anaphylaxis, p. 82 1,8				

5. Follow up¹

- If pathology taken - follow up results and advise patient:
 - if tested for m. genitalium, check if pathology states resistant to macrolides. If resistant, consult MO/NP for order for moxifloxacin (400 mg for 7 days) to replace azithromycin
- If treatment given today, advise review in:
 - **1 week** - check taking tablets, see if symptoms subsiding ± sexual contact(s) names obtained
 - **2–4 weeks** - (if needed) for **Test of cure** (ie repeat STI tests), as per table below
 - **3 months** (all) - retest for STIs to detect re-infection (common):
 - re-treat as needed. If trichomonas infection persistent or recurrent, consult MO/NP for advice¹
- If still positive for gonorrhoea on test of cure or 3 month retesting, get advice from MO/NP¹

Test of cure ¹	
Chlamydia	<ul style="list-style-type: none"> • Only needed if pregnant or rectal infection: <ul style="list-style-type: none"> – no earlier than 4 weeks after treatment completed
Gonorrhoea	<ul style="list-style-type: none"> • Only needed if pharyngeal, anal or cervical infection: <ul style="list-style-type: none"> – 2 weeks after treatment is completed
Trichomonas	<ul style="list-style-type: none"> • Not needed
M. Genitalium	<ul style="list-style-type: none"> • 14–21 days after treatment is completed

6. Referral/consultation²

- Chlamydia and gonorrhoea are notifiable (laboratory will notify) ⓘ
- Trichomonas is notifiable in the NT

HMP Bacterial vaginosis - adult

Background¹

- Bacterial vaginosis (BV) is caused by an overgrowth of vaginal bacteria. Is often asymptomatic
- BV is not considered an STI, however it can be acquired through sexual activity

1. May present with¹

- Pathology has organisms consistent with BV (eg *Gardnerella*) or clue cells present
- If symptoms - thin grey white vaginal discharge (offensive 'fishy' smelling) ± mild vulval irritation

2. Immediate management Not applicable

3. Clinical assessment¹

- BV may be diagnosed clinically if 3 or 4 of the following criteria are present:
 - thin white/grey discharge
 - vaginal fluid pH > 4.5 - take a swab and test using pH paper
 - offensive smelling 'fishy' vaginal odour
 - vaginal swab results positive for clue cells
- If discharge, do [STI/BBV tests, p. 448](#) + self collected vaginal charcoal swab for MCS (with slide)¹

4. Management^{1,2}

- If symptomatic, treat with oral metronidazole or PV clindamycin:
 - **note:** 7 day course is preferred to help prevent recurrence
- If no symptoms, treatment is not usually needed. Treat if:
 - woman requests treatment, OR
 - undergoing an invasive genital tract procedure eg insertion of an IUD
- Advise:
 - avoid douching (cleaning inside vagina) eg with soaps, bubble bath, female hygiene products
 - recurrence is common
 - treatment of partner(s) is not usually needed. If female partner, assessment recommended¹

S ₄	Metronidazole		Extended authority	
ATSIHP, IHW, IPAP and RN must consult MO/NP				
RIPRN and SRH may proceed				
Form	Strength	Route	Dose	Duration
Tablet	200 mg 400 mg	Oral	400 mg bd	7 days
			OR	
			2 g	stat
Offer CMI: Avoid alcohol for 24 hours after taking. Take with food to reduce stomach upset. May cause nausea, anorexia, abdominal pain, vomiting, diarrhoea, metallic taste, dizziness or headache				
Pregnancy: Safe to use. Give in divided doses if possible				
Management of associated emergency: Consult MO/NP. See Anaphylaxis, p. 82				
				1-3

S ₄	Clindamycin			Extended authority
ATSIHP, IHW, IPAP and RN must consult MO/NP				
RIPRN and SRH may proceed				
Form	Strength	Route	Dose	Duration
Cream	2%	PV	1 applicator full nocte	7 nights
Offer CMI: Cream may damage latex contraceptive devices and for up to 72 hours after last dose. May cause local irritation or thrush				
Pregnancy: Safe to use				
Contraindication: Allergy to clindamycin or lincomycin				
Management of associated emergency: Consult MO/NP. See Anaphylaxis, p. 82				

1,2,4

5. Follow up

- Not required¹

6. Referral/consultation

- Consult MO/NP if recurrent

HMP Vaginal thrush (candidiasis) - adult

Background¹

- *Candida* species can be normal flora - do not need treatment if asymptomatic. Can occur spontaneously or as a result of disturbance to vaginal flora eg antibiotics. **Not an STI**

1. May present with¹

- White 'curd' or 'cottage cheese' vaginal discharge
- Genital/vulval itch, discomfort
- ± painful sex, dysuria, excoriation, redness, fissures, swelling of vulval area

2. Immediate management Not applicable

3. Clinical assessment¹

- Get history and offer relevant examination. See [STI/BBV assessment, p. 445](#)
- Consider swab for culture (self collected LVS)²

4. Management¹

- Consult MO/NP if symptoms are severe or recurrent (≥ 4 acute episodes/year)
- If no symptoms, treatment is not needed
- If symptomatic, treat with PV clotrimazole. Repeat course once if needed:²
 - if pregnant, use the 6 night course^{1,3}
- Advise:
 - male sex partners only need treatment if symptomatic eg red rash on genitals ± itchy¹
 - no evidence that specific diets or use of probiotics influence recurrence of thrush
 - avoid local irritants eg soaps, bubble baths, vaginal lubricants/hygiene products

S ₃	Clotrimazole			Extended authority ATSIHP/IHW/IPAP/SRH	
ATSIHP, IHW, IPAP and RN must consult MO/NP					
MID, RIPRN and SRH may proceed					
Form	Strength	Route	Dose	Duration	
Pessary	500 mg	PV	1 pessary nocte	single dose	
	100 mg			6 nights	
OR					
Vaginal cream	1%	PV	1 applicator full nocte	6 nights	
Offer CMI: Complete course even if symptoms gone. Can damage latex contraceptive devices - do not use during treatment. If pregnant insert vaginal applicator with care					
Management of associated emergency: Consult MO/NP. See Anaphylaxis, p. 82					1-3

5. Follow up

- If swabs taken, follow up results. Consult MO/NP if *Candida glabrata* for alternative treatment^{1,3}
- Advise to return if symptoms persist after treatment
- Consider diabetes, HIV infection or other causes of immunosuppression if poorly controlled¹

6. Referral/consultation

- As above

HMP Epididymo-orchitis - adult

Background¹

- Inflammation of the epididymis and occasionally the testes
- Most common cause in men aged < 35 years is chlamydia or gonorrhoea. However, may be caused from a number of bacterial or viral infections eg enteric organisms (*E. coli*), mumps, syphilis, melioidosis²

1. May present with¹

- Pain and swelling in the testes/scrotum - usually only one side

2. Immediate management¹

- If sudden onset or severe pain treat as [Testicular torsion, p. 209](#) until proven otherwise
- **Testicular torsion must be excluded in anyone with testicular pain - a medical emergency**

3. Clinical assessment¹⁻³

- Get history, including:
 - onset - gradual/sudden
 - severity
 - location/radiation of pain eg to abdomen, suprapubic area
 - other symptoms - fever, penile discharge, dysuria, nausea, vomiting, viral illness
 - recent IDC/instrumentation to urinary tract
 - [STI/BBV assessment, p. 445](#)
 - recent trauma to testes

- Do vital signs +
 - urinalysis and MSU for MCS
 - [STI/BBV tests, p. 448](#) as per someone with symptoms
- Examine testes:^{1,3}
 - check for tender epididymis (tubular structure at back of testicle, running in sagittal plane)
 - swelling, redness, hot
 - position - normal or pulled up
 - check cremasteric reflex - pinch or stroke the skin of the upper thigh. The testicle on the same side should elevate via contraction of the muscle (should be intact. If not intact likely testicular torsion)
- **Assess against differential diagnosis table in [Testicular/scrotal pain, p. 209](#)**

4. Management

- Always consult MO/NP
- Offer analgesia. See [Acute pain, p. 32](#)
- If sexually active, treat now for chlamydia + gonorrhoea - **do not wait for pathology results:**^{1,2}
 - IM ceftriaxone* stat + **EITHER** azithromycin stat + repeat in 1 week **OR** doxycycline for 14 days
 - ***note:** if area has high penicillin susceptibility to gonorrhoea (as advised by local sexual health specialist or AMS program), MO/NP may advise to replace ceftriaxone with amoxicillin + probenecid. See [Chlamydia, gonorrhoea, trichomonas, m. genitalium, p. 452](#) for drug boxes
- If not sexually active, is usually caused by an organism from the urinary tract:
 - MO/NP may order oral antibiotics eg trimethoprim 300 mg daily for 2 weeks²
- Advise:
 - bed rest, regular analgesia eg paracetamol, cool compresses and scrotal support as needed¹
 - should see improvement in 4–5 days. Swelling can take several weeks to go away completely
- If STI likely, advise:
 - no sexual activity for **7 days** after treatment completed
 - ask for names of sexual partners from prior **6 months** and start [Contact tracing, p. 450](#)
 - no sex with partners from prior **6 months** until they have been tested + treated if needed
 - use condoms
 - offer advice/fact sheet(s) about STI/BBVs

S4		Ceftriaxone	Extended authority ATSIHP/IHW/IPAP/RIPRN/SRH	
ATSIHP, IHW, IPAP and RN must consult MO/NP				
RIPRN and SRH may proceed				
Form	Strength	Route	Dose	Duration
Injection	1 g	IM	500 mg (2 mL)	stat Give by deep injection into gluteal muscle
		Reconstitute with lidocaine (lignocaine) 1% 3.5 mL to make up 1 g/4 mL		
Offer CMI: May cause nausea, diarrhoea, rash, headache or dizziness				
Note: If renal impairment seek MO/NP advice				
Contraindication: Severe or immediate allergic reaction to a cephalosporins or a penicillin. Be aware of cross-reactivity between penicillins, cephalosporins and carbapenems				
Management of associated emergency: Consult MO/NP. See Anaphylaxis, p. 82				1,2,4

S4	Azithromycin			Extended authority	
ATSIHP, IHW, IPAP and RN must consult MO/NP					
RIPRN and SRH may proceed					
Form	Strength	Route	Dose	Duration	
Tablet	500 mg	Oral	1 g	stat and repeat in 1 week	
Offer CMI: May cause rash, diarrhoea, nausea, abdominal cramps or thrush					
Management of associated emergency: Consult MO/NP. See Anaphylaxis, p. 82 1,2,5					

S4	Doxycycline			Extended authority	
ATSIHP, IHW, IPAP and RN must consult MO/NP					
RIPRN and SRH may proceed					
Form	Strength	Route	Dose	Duration	
Tablet	50 mg, 100 mg	Oral	100 mg bd	14 days	
Offer CMI: Take with food or milk to reduce stomach upset. May cause nausea, vomiting, diarrhoea, epigastric burning, tooth discolouration or photosensitivity. Take with a large glass of water. Do not lie down for an hour after taking. Do not take iron, calcium, zinc or antacids within 2 hours. Avoid sun exposure					
Contraindication: Serious allergy to tetracyclines. Taking oral retinoids					
Management of associated emergency: Consult MO/NP. See Anaphylaxis, p. 82 1,2,6					

5. Follow up

- Advise review:
 - **next day**, or sooner if concerned or increased pain/swelling. If not improving, consult MO/NP. May need referral for USS
 - **in 4–5 days:**
 - check response to treatment, review pathology results and reassess treatment as needed
 - if pain and swelling have not substantially reduced, consult MO/NP. Antibiotics may need continuing for up to 3 weeks²
 - **if STI related:**¹
 - ensure contact tracing underway¹
 - needs test for re-infection/proof of cure (for gonorrhoea) in **3 months**

6. Referral/consultation

- In severe cases, treatment may need to be continued for up to 3 weeks. Seek specialist advice¹

HMP Low abdominal pain in female/person with uterus

Probable pelvic inflammatory disease (PID)

Recommend

- Consider ectopic pregnancy in all women who present with abdominal pain
- PID must be considered in all sexually active people with a uterus with low abdominal pain. Prompt treatment is essential to avoid long-term problems eg infertility¹
- Diagnosis of PID is clinical. **Do not wait for pathology results** - response to treatment confirms the diagnosis

Background¹

- PID is a syndrome comprising a spectrum of inflammatory disorders of the upper genital tract, including any combination of endometritis, salpingitis, tubo-ovarian abscess and pelvic peritonitis - varies in severity and symptoms
- Cause may be polymicrobial, STIs, vaginal bacteria, or unknown (up to 70% of cases)¹

1. May present with¹

- Low pelvic pain - like period pain:
 - typically bilateral - may worsen with movement and localise to one side
 - may refer to upper right quadrant
- May also have:
 - painful deep sex (dyspareunia), vaginal discharge or bleeding (spotting) eg between menstrual periods/after sex, or heavy/long periods
 - fever, nausea, vomiting - indicates severe infection

2. Immediate management

- Vital signs
- **Do pregnancy test** - if +ve assume [Ectopic pregnancy, p. 371](#) until proven otherwise:
 - urgently consult MO/NP
- If severe pain:
 - offer analgesia. See [Acute pain, p. 32](#)
 - do rapid history and assessment. See [Abdominal pain, p. 196](#)
 - insert IVC
 - nil by mouth
 - urgently consult MO/NP, who will advise further management/arrange evacuation

3. Clinical assessment^{1,2}

- Get history of pain. Also ask about:
 - dysuria/frequency of urine
 - fever, nausea, vomiting, any other symptoms
 - date of last menstrual period
 - sexual history. See [STI/BBV assessment, p. 445](#)
 - recent uterine instrumentation eg termination of pregnancy, IUD insertion, fertility/IVF
 - prior PID
- Do examination as per [Abdominal pain, p. 196](#) +
 - urinalysis - any nitrites, leucocytes
 - [STI/BBV tests, p. 448](#) as per someone with symptoms

- If clinician skilled, do speculum/bimanual examination:¹
 - PID likely if cervical motion tenderness, uterine/adnexal tenderness ± cervical discharge
 - get HVS for chlamydia, gonorrhoea, trichomonas and m. genitalium + offer CST if due
 - **note:** ability to do speculum/bimanual examination is **not essential** for presumptive diagnosis and treatment of PID¹
- Use the following table as a guide to differential diagnoses

Differential diagnosis - low abdominal pain in female/person with uterus^{1,3}

Possible causes (may be multiple)	Clues to diagnosis
<ul style="list-style-type: none"> • Pregnancy test +ve • Ectopic pregnancy 	<ul style="list-style-type: none"> • Assume Ectopic pregnancy, p. 371 until proven other wise • Medical emergency
<ul style="list-style-type: none"> • Pregnancy test –ve • Consider: <ul style="list-style-type: none"> – PID – UTI – ovarian cyst or tumour/abscess – appendicitis – pelvic adhesions – endometriosis – uterine fibroids – diverticulitis • Also see Abdominal pain, p. 196 	<ul style="list-style-type: none"> • PID is likely if any of:¹ <ul style="list-style-type: none"> – low abdominal pain alone is present – new onset of pelvic pain in women < 25 years (highly predictive of PID) – sexually active and living in an area where gonorrhoea, chlamydia and m. genitalium are common – recent sexual partner change, partner with STI/symptoms, recent uterine instrumentation or pregnancy • Rapid response to treatment is highly predictive of PID • UTI - adult, p. 295 is likely if presence of nitrites or leucocytes PLUS prominent symptoms of dysuria and frequency • Appendicitis - typically pain moves from umbilicus to right iliac fossa; low grade fever, anorexia, nausea, vomiting • Endometriosis - cyclic pain (PID is not cyclic)³ • Uterine fibroids/diverticulitis - uncommon in women < 40 • Ovarian tumour - bloating, feeling full quickly, frequent or urgent urination. More common > 50 years

4. Management¹

- Offer analgesia. See [Acute pain, p. 32](#)
- Consult MO/NP if:
 - pregnant
 - abnormal vaginal bleeding
 - diagnosis uncertain, PID unlikely, or surgical emergency cannot be excluded
 - **severe PID suspected** - severe pain or systemically unwell eg nausea, vomiting, fever
- **If severe PID suspected:**
 - consult MO/NP, who may advise IV antibiotics + evacuation/hospitalisation
- **If mild–moderate PID suspected:**
 - start antibiotics immediately - **do not wait for pathology results**
 - pain responds quickly to antibiotic treatment (this helps confirm the diagnosis)
 - **advise patient:**
 - the pain should resolve within 3 days
 - current sexual partner(s) need to be treated for chlamydia (and gonorrhoea if likely) as soon as possible, irrespective of pathology results⁴
 - no sex for 7 days after treatment **AND** symptoms gone¹ **AND** current partner(s) has been treated
 - when and how they will get pathology results

- about PID/complications if untreated. Offer fact sheet eg <https://www.staystifree.org.au/get-the-facts/pelvic-inflammatory-disease>

Antibiotics for suspected mild–moderate PID^{1,2}

- IM ceftriaxone* stat **PLUS** oral doxycycline for 14 days **PLUS** oral metronidazole for 14 days:
 - ***note:** if area has high penicillin susceptibility to gonorrhoea (as advised by local sexual health specialist or AMS program), replace ceftriaxone with amoxicillin + probenecid. See [Chlamydia, gonorrhoea, trichomonas, m. genitalium, p. 452](#) for drug boxes
- If pregnant/breastfeeding OR not likely to adhere to doxycycline, replace doxycycline with azithromycin single dose, repeated 1 week later^{1,2}

S ₄	Ceftriaxone				Extended authority
ATSIHP, IHW, IPAP and RN must consult MO/NP					
RIPRN and SRH may proceed					
Form	Strength	Route		Dose	Duration
Injection	1 g	IM Reconstitute with lidocaine (lignocaine) 1% 3.5 mL to make up 1 g/4 mL		500 mg (2 mL)	stat Give by deep injection into gluteal muscle
Offer CMI: May cause nausea, diarrhoea, rash, headache or dizziness					
Note: If renal impairment seek MO/NP advice					
Contraindication: Severe or immediate allergic reaction to a cephalosporins or a penicillin. Be aware of cross-reactivity between penicillins, cephalosporins and carbapenems					
Management of associated emergency: Consult MO/NP. See Anaphylaxis, p. 82					
					1,2,5

S ₄	Doxycycline				Extended authority
ATSIHP, IHW, IPAP and RN must consult MO/NP					
RIPRN and SRH may proceed					
Form	Strength	Route	Dose		Duration
Tablet	50 mg, 100 mg	Oral	100 mg bd		14 days
Offer CMI: Take with food or milk to reduce stomach upset. May cause nausea, vomiting, diarrhoea, epigastric burning, tooth discolouration or photosensitivity. Take with a large glass of water. Do not lie down for an hour after taking. Do not take iron, calcium, zinc, or antacids within 2 hours. Avoid sun exposure					
Pregnancy: Safe in the first 18 weeks					
Contraindication: Serious allergy to tetracyclines. Taking oral retinoids. After 18 weeks of pregnancy					
Management of associated emergency: Consult MO/NP. See Anaphylaxis, p. 82					
					1,8

S ₄	Metronidazole				Extended authority
ATSIHP, IHW, IPAP and RN must consult MO/NP					
RIPRN and SRH may proceed					
Form	Strength	Route	Dose	Duration	
Tablet	200 mg, 400 mg	Oral	400 mg bd	14 days	
Offer CMI: Avoid alcohol while taking and for 24 hours after finishing the course. Take with food to reduce stomach upset. May cause nausea, anorexia, abdominal pain, vomiting, diarrhoea, metallic taste, dizziness or headache					
Management of associated emergency: Consult MO/NP. See Anaphylaxis, p. 82					
					1,6

S₄	Azithromycin			Extended authority ATSIHP/IHW/IPAP/RIPRN/SRH
ATSIHP, IHW, IPAP and RN must consult MO/NP				
RIPRN and SRH may proceed				
Form	Strength	Route	Dose	Duration
Tablet	500 mg	Oral	1 g	stat and repeat in 1 week
Offer CMI: May cause rash, diarrhoea, nausea, abdominal cramps or thrush				
Management of associated emergency: Consult MO/NP. See Anaphylaxis, p. 82				1,7

5. Follow up¹

- Follow up pathology results. If positive for an STI(s):
 - if m. genitalium ADD moxifloxacin 400 mg for 14 days. Requires MO/NP order from pharmacy¹
 - start contact tracing + advise **test of cure** and **retesting**. See [Chlamydia, gonorrhoea, trichomonas, m. genitalium, p. 452](#) for guidance
- Advise review on day 3** or sooner if pain or symptoms worsen or concerned:
 - check taking tablets, ask if symptoms subsiding + ensure current partner(s) treated for chlamydia ± gonorrhoea and had STI/BBV tests
 - if pain/symptoms not improved or worsened, consult MO/NP for further evaluation ± hospitalisation and IV antibiotics
- Advise review again in 1 week:**
 - repeat pregnancy test if indicated
 - ensure pathology results given

6. Referral/consultation

- If pain recurs, reassess for PID and consult MO/NP for further evaluation

HMP Anogenital ulcers/lumps - adult

Recommend¹

- Syphilis must be considered for any genital sore, particularly in Aboriginal and Torres Strait Islander people, men who have sex with men (MSM), female partners of MSM and people who use drugs

Background²

- There is currently an outbreak of syphilis in Aboriginal and Torres Strait Islander populations in Qld, NT, WA and SA. In these areas, all genital ulcers should be considered to be potential syphilis
- Ulcers** can be caused from herpes (most common), syphilis, or rarely donovanosis or lymphogranuloma venereum (LGV)
- Lumps** (papules/nodules/vesicles) can be caused from HPV (warts), herpes simplex virus or syphilis

1. May present with

- Lumps, sores or ulcers in the genital/anogenital area

2. Immediate management Not applicable

3. Clinical assessment^{1,2}

- Get history as per [STI/BBV assessment, p. 445](#). Also ask about:
 - onset date (if known) of sore/symptoms
 - location/duration
 - characteristics of ulcers/lumps eg itching, painful, tingling
 - any fever, headache, muscle aches and pains, rashes
 - previous episodes of genital sores, when/how (if) treated
 - prior syphilis (check records) or herpes
 - does current partner have symptoms/signs of an STI
 - recent overseas travel; where, did they have sex while overseas
- Do vital signs
- Do physical examination, including:
 - skin for rash - also check palms of hands and soles of feet
 - genital and anal area - lump(s), sore(s)/ulcer(s), vesicle(s), discharge
 - mouth - ulcers/mucous patches
 - enlarged ± tender lymph nodes - groin, armpits and neck
 - any patchy hair/eyebrow loss
- Do:
 - [STI/BBV tests, p. 448](#) as per someone with symptoms
 - + swab of ulcer/sore for syphilis and herpes PCR (from base of lesion or deroofted vesicle)
 - pregnancy test if female of reproductive age

Common causes of anogenital lumps and sores (infections can co-exist)²

	Genital herpes	Syphilis	Anogenital warts
Typical sores/lumps	<ul style="list-style-type: none"> • Single or multiple skin splits or cluster of blisters • Break down to form small shallow ulcers • Surrounding skin may be inflamed • Initial episodes may be severe with extensive ulceration and systemic features 	<ul style="list-style-type: none"> • Primary - (chancere) usually 1 ulcer or sore with well defined edges and hard/firm base, does not bleed - feels like a hard button on the skin¹ • Multiple lesions can occur • Can also occur on anal skin, cervix or in mouth/lips • Secondary - (condylomata lata) multiple warty (large, raised, whitish or grey, flat-topped) growths in anogenital/warm/moist areas.¹ May have rash on trunk or just palms and soles + patchy hair loss 	<ul style="list-style-type: none"> • Warty growths in and around genital skin • Solid lump • May be seen on cervix in female • Less common since HPV vaccine started
Painful	<ul style="list-style-type: none"> • Itchy/tingling • May be painful 	<ul style="list-style-type: none"> • Usually painless • Can be painful if infected 	<ul style="list-style-type: none"> • Little discomfort, sometimes itchy • Can be painful, on moist areas, anus/labia
Enlarged lymph nodes	<ul style="list-style-type: none"> • Yes/no 	<ul style="list-style-type: none"> • Usually enlarged, rubbery and non-tender 	<ul style="list-style-type: none"> • No
Heals without treatment	<ul style="list-style-type: none"> • Yes, within 1–2 weeks • May recur 	<ul style="list-style-type: none"> • Yes, primary sores heal within a few weeks. Secondary lesions may come and go over 12–24 months 	<ul style="list-style-type: none"> • Yes/no • May resolve after 1–2 years³

Other causes of genital sores/ulcers to consider²

- Scabies/impetigo, folliculitis, normal anatomical variations, immunological conditions, trauma, cancer, Crohn's disease
- **Molluscum contagiosum virus** - multiple pearl like, smooth papules, with small depression, usually in groin and inner thigh in adults. Common in children⁴
- **Donovanosis** (rare) - shallow ulcers, bleed on contact or raised 'beefy' lesions or combination. Usually painless, no enlarged lymph nodes. Does not heal without treatment - gets larger over time
- **Lymphogranuloma venereum (LGV)** (rare) - small ulcer/nodule on penis/vulva/anus (may go unnoticed), proctitis. More likely in MSM

4. Management^{1,2}

- There is currently an outbreak of syphilis in Aboriginal and Torres Strait Islander populations in Qld, NT, WA and SA. In these areas, all genital ulcers should be considered to be potential syphilis¹
- Offer analgesia. See [Acute pain, p. 32](#)
- **If syphilis suspected or unsure:**
 - give benzathine benzylpenicillin (Bicillin LA®) (single dose) as per drug box in [Syphilis, p. 468](#)
 - **do not wait for pathology results**
 - notify Qld Syphilis Surveillance Service (QSSS) ☎ 1800 032 238 or North-Qld-Syphilis-Surveillance-Centre@health.qld.gov.au or QLD-Syphilis-Surveillance-Service@health.qld.gov.au. If outside Qld, your local Public Health Unit/syphilis register
- **If genital warts suspected** consider condylomata lata (syphilis) as differential diagnosis:
 - swab the lesion and presumptively treat as syphilis if in an outbreak area. If syphilis result is negative, then treat as [Anogenital warts, p. 474](#)
- **If lesions typical of genital herpes:**
 - treat as per [Genital herpes, p. 472](#)
 - do not wait for pathology results

5. Follow up

- Follow up pathology results:
 - if primary syphilis, there may be a false –ve result in early infection. Repeat syphilis serology after 2 weeks if clinically suspicious
- Advise to be reviewed in **1 week**, or sooner if concerned:
 - check lesion(s), advise patient of pathology results
- Consult MO/NP if sores/ulcers do not respond to treatment, who may consider differential diagnoses/biopsy for histology

6. Referral/consultation¹

- Suspected and confirmed syphilis is notifiable ☎. Contact QSSS ☎ 1800 032 238. If outside Qld, contact your local Public Health Unit/syphilis register

HMP Syphilis - adult

Recommend^{1,2}

- Regular screening and prompt treatment for syphilis in high risk people eg:
 - Aboriginal and Torres Strait Islander people in Qld, NT, WA and SA
 - men who have sex with men (MSM); female partners of MSM
 - pregnant women
 - people in correctional facilities
- Manage all syphilis in collaboration with the [Qld Syphilis Surveillance Service \(QSSS\)](#):
 - ☎ 1800 032 238 North Qld North-Qld-Syphilis-Surveillance-Centre@health.qld.gov.au; South Qld QLD-Syphilis-Surveillance-Service@health.qld.gov.au. If outside Qld, your local Public Health Unit/syphilis register

Background

- There is currently an outbreak of syphilis in Aboriginal and Torres Strait Islander populations in Qld, NT, WA and SA¹
- There have been several deaths from congenital syphilis in Qld (baby acquires syphilis during pregnancy). This is completely preventable with adequate testing and management
- Resource - *Decision making in syphilis* <https://www.ashm.org.au/resources>

1. May present with^{1,2}

- Symptoms suggesting syphilis (see table below)
- Positive pathology results
- Sexual contact of someone who has syphilis confirmed by pathology OR with symptoms of syphilis

Symptoms of syphilis (can vary). Often no symptoms¹		
Infectious syphilis	Primary syphilis 10–90 days after infection	<ul style="list-style-type: none"> • Ulcer(s) or chancre(s) at site of infection - painful or painless: <ul style="list-style-type: none"> – single or multiple. Well-defined margin + hard/firm base – goes away within a few weeks; may go unnoticed • Inguinal lymph nodes enlarged, rubbery and non tender¹
	Secondary syphilis 4–10 weeks after onset of primary lesion	<ul style="list-style-type: none"> • Rash - on trunk; may just affect palms and soles (can be dry/scaly) • Patchy hair loss eg part of eyebrow • Condylomata lata (warty growths in anogenital region) - large, raised, whitish or grey, flat-topped • Mucous patches - oral/genitals (painful or painless) • Fever, malaise, headache, ocular or CNS symptoms, enlarged lymph nodes • Symptoms slowly go away after 3–12 weeks, but may recur
	Early latent syphilis	<ul style="list-style-type: none"> • Infectious syphilis of < 2 years duration • Positive syphilis serology with no clinical signs or symptoms
	Late latent syphilis	<ul style="list-style-type: none"> • Syphilis > 2 years duration. Can be asymptomatic for many years
Tertiary syphilis	<ul style="list-style-type: none"> • Occurs in about 1/3 of untreated people • Skin lesions (gummas), cardiovascular or neurological disease 	

2. Immediate management Not applicable

3. Clinical assessment^{1,2}

- Do **STI/BBV assessment**, p. 445 + ask about:
 - symptoms of syphilis - what, onset, duration + ask if any symptoms in last 2 years
 - sexual history + does current partner have symptoms of syphilis
 - prior diagnosis of syphilis - year of diagnosis, dates of treatment, where done
- Do physical examination, including:
 - vital signs
 - look for any signs of syphilis
 - pregnancy test if female of reproductive age
 - **STI/BBV tests**, p. 448 if not done already
- Get prior syphilis serology results - check medical record + contact QSSS ☎ 1800 032 238

4. Management¹⁻³

- **Treat now as ‘infectious syphilis’** (do not wait for pathology results) **if**:
 - symptoms suggest syphilis
 - **OR** person is a sexual contact of someone with:
 - symptoms of syphilis **OR**
 - positive pathology results for syphilis
- Give benzathine benzylpenicillin (Bicillin LA®) (**single dose**) if not allergic:
 - advise QSSS that you are treating + why

Pathology results

- Syphilis serology can be hard to interpret. ‘Reactive’ does not always mean current infection or treatment needed
- If PCR swab of lesion done, diagnosis of syphilis can be confirmed by presence of *T. pallidum*¹

Syphilis serology			
EIA, TPPA^ TPHA, FTA	RPR#	Likely interpretation	Action
Non reactive	Non reactive	<ul style="list-style-type: none"> • No syphilis, OR • Incubating syphilis 	<ul style="list-style-type: none"> • No action • If you still suspect syphilis eg symptoms, contact QSSS ± treat today
If any of below contact QSSS ☎ 1800 032 238 Will help interpret results, work out stage of syphilis + advise treatment			
Reactive	Reactive	<ul style="list-style-type: none"> • Could be current OR prior infection 	<ul style="list-style-type: none"> • Check RPR titre against prior RPR titre(s)* • Assume new infection if ≥ 2 titre (4 fold) ↑ compared to last titre (regardless of what the titre is) eg 1:4 is now 1:16 or more • Ask about history of symptoms of syphilis
Non reactive	Reactive	<ul style="list-style-type: none"> • May be false positive 	<ul style="list-style-type: none"> • Retest after 2–4 weeks
Reactive <i>May be false positive if only 1 reactive</i>	Non reactive	<ul style="list-style-type: none"> • Primary or latent syphilis OR prior treated syphilis 	<ul style="list-style-type: none"> • Ask about history of symptoms of syphilis • Retest after 2–4 weeks if suspected false positive
#A reactive RPR may be reported as a ‘titre’ eg: 1:1, 1:2, 1:4, 1:8, 1:16, 1:32, 1:64, 1:128 etc. The titre rises in early infection and falls over 2 years, regardless of treatment. It is measured by serial dilutions ^If prior treated syphilis, since the EIA and TPPA tests are usually positive for life, only an RPR test is needed to detect reinfection or treatment success ¹			

Syphilis in pregnancy³

- If syphilis suspected or confirmed in a pregnant woman OR her partner:
 - treat both **URGENTLY** in consultation with specialist MO + QSSS
 - diagnosis and treatment is the same as for a non-pregnant woman, although more frequent follow up may be needed
- Refer to Qld Clinical Guideline *Syphilis in pregnancy* <https://www.health.qld.gov.au/qcg/publications>
- For testing in pregnancy, see [Antenatal care, p. 364](#). Extra testing needed if [Increased/high risk of syphilis, p. 368](#)

Treatment

- Treat with benzathine benzylpenicillin (Bicillin LA®) as per stage of syphilis/QSSS advice
- Take syphilis serology on 1st day of treatment - assists with syphilis staging + to use as a baseline to monitor response to treatment (do serology again if recently done)

S ₄	Benzathine benzylpenicillin (Bicillin LA®)			Extended authority ATSIHP/IHW/IPAP/MID/RIPRN/SRH
ATSIHP, IHW, IPAP and RN must consult MO/NP				
MID, RIPRN and SRH may proceed				
Form	Strength	Route	Dose	Duration
Prefilled syringe	1.2 million units/2.3 mL (900 mg)	IM	2.4 million units (1.8 g) 2 prefilled syringes	Infectious syphilis Single dose stat
				Late latent syphilis or of unknown duration Once a week for 3 weeks
Offer CMI: May cause diarrhoea, nausea and pain at injection site. Jarisch-Herxheimer reaction can happen with treatment of early syphilis causing - fever, chills, headache, hypotension, flare up of lesions, preterm labour (but this should not prevent or delay treatment as consequences of untreated syphilis are significantly worse). Lasts for 12–24 hours. Manage with paracetamol as needed				
Note: Give in 2 separate sites. Ventrogluteal, p. 564 or vastus lateralis preferred. Do not give in deltoid. See Managing injection pain, p. 563				
Pregnancy: Only penicillin is effective, seek urgent expert advice if allergic ¹				
Contraindication: Severe or immediate allergic reaction to a penicillin. Be aware of cross-reactivity between penicillins, cephalosporins and carbapenems. Contact QSSS/Public Health Unit				
Management of associated emergency: Consult MO/NP. See Anaphylaxis, p. 82				

1,3

Contact tracing/partner notification¹

- Do [Contact tracing, p. 450](#) if symptoms of syphilis, or as per 'stage of infection' (QSSS will advise)
- Contacts must be followed up **promptly, URGENTLY if pregnant**. For each contact:
 - [STI/BBV tests, p. 448](#) including syphilis serology
 - ask about/check for symptoms of syphilis - prior or current
 - treat immediately with benzathine benzylpenicillin (Bicillin LA®) single dose. Do not wait for pathology results
- Contact QSSS if having problems with contact tracing

Stage of infection	How far to trace back, test + treat
Primary syphilis	<ul style="list-style-type: none"> • 3 months + duration of symptoms or last negative test
Secondary syphilis	<ul style="list-style-type: none"> • 6 months + duration of symptoms or last negative test
Early latent syphilis or unknown origin	<ul style="list-style-type: none"> • 12 months or from most recent negative test
Late latent/tertiary syphilis	<ul style="list-style-type: none"> • Current partner(s). If any doubt as to whether the patient has early late or late latent syphilis, contact trace as for early latent syphilis

In all cases

- If treated for infectious syphilis - **no sex** for **7 days** after treatment of patient and partner(s)
- Offer fact sheet eg <https://youngdeadlyfree.org.au/resources/factsheets/>
- Continue having regular STI/BBV checks + use condoms

5. Follow up

- Follow up pathology results. **Note:** all reactive results automatically get sent to QSSS
- Advise to return in **1–2 weeks** to check:
 - response to treatment (if symptoms)
 - any other contacts they have thought of
 - give pathology results
- **If 3 dose treatment** - ensure patient is followed up for each dose:
 - notify QSSS when dose(s) given
 - if a weekly dose is missed consult QSSS for advice
- **Follow up at 3, 6 and 12 months for infectious syphilis** to monitor response to treatment:
 - do repeat syphilis serology + **STI/BBV tests**, p. 448 each time
 - a 2 titre or 4 fold fall in RPR by 6 months indicates adequate response eg 1:32 is now 1:8, or 1:128 is now 1:32
 - do in collaboration with QSSS

6. Referral/consultation

- Suspected and confirmed syphilis is notifiable ☺:
 - contact QSSS ☺ 1800 032 238 North-Qld-Syphilis-Surveillance-Centre@health.qld.gov.au (North Qld) or QLD-Syphilis-Surveillance-Service@health.qld.gov.au (South Qld)
 - if outside Qld, your local Public Health Unit/syphilis register

HMP Genital herpes simplex virus (HSV) - adult

Recommend¹

- Syphilis must be considered for any genital sore, particularly in Aboriginal and Torres Strait Islander people, men who have sex with men (MSM), female partners of MSM and people who use drugs

Background

- HSV is the most common cause of genital ulcer disease in Australia² and is often acquired without symptoms.¹ More than 50% of initial genital episodes are now caused by HSV type 1¹

1. May present with^{1,2}

- Recurrent skin splits, ulcers or blisters in anogenital area
- Redness with itching/tingling, may be painful
- Initial episodes may be severe with extensive ulceration and systemic features eg fever, headache

2. Immediate management Not applicable

3. Clinical assessment^{1,2}

- Get history + do examination as per [STI/BBV assessment, p. 445](#)
- Ask if prior herpes/cold sores
- Do vital signs
- Do pregnancy test if female of reproductive age
- If no prior history of herpes, or not typical (for patient) of recurrent herpes infections, do:
 - [STI/BBV tests, p. 448](#) as per someone with symptoms
 - swab of ulcer/sore for syphilis and herpes PCR (from base of lesion or deroofed vesicle)²

4. Management^{1,2}

- Consider differential diagnoses as per [Anogenital ulcers/lumps, p. 465](#)
- If clinically suggestive of herpes:
 - treat with valaciclovir (do not wait for pathology results) - can shorten episode if started within 72 hours of symptom onset
 - **if pregnant** consult MO/NP for treatment
- If herpes likely, but uncertain:
 - also treat presumptively as [Syphilis, p. 468](#) + notify Qld Syphilis Surveillance Service ☎ 1800 032 238. If outside Qld, your local Public Health Unit/syphilis register
- Advise:
 - antiviral treatment does not cure herpes, but can lessen severity/symptoms
 - **for relief of pain/symptoms:**
 - take paracetamol. See [Acute pain, p. 32](#)
 - lidocaine (lignocaine) gel or similar may be tried
 - saline/salt water bathing
 - urinate while in bath or shower to relieve dysuria
 - condom use with ongoing + new partners, as can be transmitted without symptoms
- Offer fact sheet eg <http://conditions.health.qld.gov.au/HealthCondition/condition/14/188/62/genital-herpes>
- Contact tracing not needed¹

- **For recurrent episodes:**¹
 - offer supply of valaciclovir or famciclovir for patient to keep with them for prompt initial treatment at the onset of symptoms eg itching/tingling
 - suppressive therapy (continuous or interrupted) may be prescribed by MO/NP if frequent episodes. Can reduce recurrences by 70%–80% and halve the rate of transmission²

S ₄	Valaciclovir			Extended authority ATSIHP/IHW/IPAP/RIPRN/SRH	
ATSIHP, IHW, IPAP and RN must consult MO/NP					
RIPRN and SRH may proceed					
Form	Strength	Route	Dose	Duration	
Tablet	500 mg	Oral	500 mg bd	First episode 10 days. If responds quickly, stop after 5 days Recurrent episodes 3 days	
Offer CMI: Drink plenty of fluids - at least 1.5 L/day. May cause dizziness or confusion					
Note: If renal impairment seek MO/NP advice					
Pregnancy: Aciclovir preferred. Valaciclovir may be used from 36 weeks gestation					
Contraindication: Allergy to valaciclovir or aciclovir					
Management of associated emergency: Consult MO/NP. See Anaphylaxis, p. 82 1,3					

S ₄	Famciclovir			Extended authority ATSIHP/IHW/IPAP/RIPRN/SRH	
ATSIHP, IHW, IPAP and RN must consult MO/NP					
RIPRN and SRH may proceed					
Form	Strength	Route	Dose	Duration	
Tablet	250 mg	Oral	1 g bd	Recurrent episodes 1 day	
Offer CMI: May cause headache, vomiting or diarrhoea					
Note: If renal impairment seek MO/NP advice					
Pregnancy: Aciclovir preferred					
Contraindication: Allergy to penciclovir					
Management of associated emergency: Consult MO/NP. See Anaphylaxis, p. 82 1,4					

5. Follow up¹

- Follow up pathology results
- Advise to be reviewed in 1 week:
 - give pathology results
 - check response to treatment
 - do [STI/BBV tests, p. 448](#) if unable to do at initial visit
 - provide support/information as required
- If symptoms not resolving, consult MO/NP - consider other causes
- Contact tracing not needed

6. Referral/consultation

- Genital herpes is not notifiable

HMP Anogenital warts - adult

Human papilloma virus (HPV)

Recommend^{1,2}

- Syphilis must be considered for any genital sore, particularly in Aboriginal and Torres Strait Islander people, men who have sex with men (MSM), female partners of MSM and people who use drugs
- Encourage HPV vaccination

1. May present with¹

- Warty growths in and around anogenital skin
- Little discomfort, sometimes itchy

2. Immediate management Not applicable

3. Clinical assessment¹

- Get history + do examination as per [STI/BBV assessment, p. 445](#)
- Do vital signs
- Do [STI/BBV tests, p. 448](#) including syphilis serology
- There is no specific diagnostic test for HPV - usually diagnosed by visual appearance

4. Management¹

- Consider differential diagnoses as per [Anogenital ulcers/lumps, p. 465](#)
- As warts are less common since HPV vaccination, **syphilis may be more likely** - condylomata lata, a symptom of syphilis, also presents as warty like growths. If condylomata lata possible:
 - treat presumptively as [Syphilis, p. 468](#) + notify Qld Syphilis Surveillance Service (QSSS)
 - ① 1800 032 238, or if outside Qld, your local Public Health Unit/syphilis register
 - if syphilis result is negative, then treat as genital warts
- **Advise to see MO/NP at next clinic if:**
 - pregnant
 - atypical lesion eg variable pigmentation, raised plaque like lesion(s) or cervical warts. Histology biopsy may be needed to exclude cancer¹
 - in anus or in urethral opening (male) - may need cryotherapy or surgical management
 - HIV positive
- **Otherwise, for uncomplicated warts, treatment options include:**
 - podophyllotoxin cream or paint (patient can apply):
 - paint is suited for use on external skin
 - cream is best used for the perianal area, vaginal opening and under the foreskin
 - weekly cryotherapy (eg liquid nitrogen or nitrous oxide with cryogun) - by skilled clinician
- Advise:
 - treatment is cosmetic rather than curative. Warts may re-appear after treatment. In most people the virus clears by itself in 1–2 years
 - if warts are in the pubic region avoid shaving or waxing - may facilitate local spreading
 - condoms can help protect against HPV
- Offer fact sheet eg <http://conditions.health.qld.gov.au/HealthCondition/home/topic/14/188/sexually-transmitted-diseases>

S ₄	Podophyllotoxin		Extended authority	
ATSIHP, IHW, IPAP and RN must consult MO/NP				
RIPRN and SRH may proceed				
Form	Strength	Route	Dose	Duration
Cream	0.15%	Topical	Apply to wart(s) bd	3 days then no treatment for 4 days Repeat as above for up to 4–6 cycles
Paint	0.5%			
Offer CMI: If you have sex, apply the treatment afterwards or wash it off if already applied. May cause burning, inflammation, pain, erosion or itch. Do not use on broken skin. Avoid contact with eyes. Before applying, wash affected area with mild soap and water and allow to dry. Wash hands before and after use; avoid bathing or showering after application				
Note: If possible, clinician to apply the first treatment and instruct the patient in proper use				
Pregnancy: Contraindicated				
Management of associated emergency: Consult MO/NP				1,3,4

5. Follow up

- Contact tracing not needed
- Follow up pathology results and advise patient
- Do [STI/BBV tests](#), p. 448 if unable to do at initial visit
- Advise patient to see MO/NP/sexual health RN if symptoms do not resolve or if feeling anxious

6. Referral/consultation

- HPV is not notifiable

Human immunodeficiency virus (HIV) - adult

Recommend

- Normalise HIV testing as much as possible¹
- If HIV positive **start antiretroviral therapy (ART) as soon as possible** after diagnosis²
- If exposed to HIV, offer Post-Exposure Prophylaxis (PEP) within 72 hours⁴
- If HIV negative but at risk of getting HIV, offer Pre-Exposure Prophylaxis (PrEP) to prevent infection³

Background^{1,2}

- HIV infection is treated with life long ART:
 - treatment is highly effective and people can expect to live a normal/near-normal life expectancy
 - ART reduces viral load of HIV. **Undetectable viral load = Untransmissible**
- Failure to diagnose HIV can result in serious illness and onward transmission to others¹
- Self test kits are now approved for use in Australia¹ eg <https://www.atomohivtest.com/home.php>
- **Resources**
 - HIV information/fact sheets eg <https://www.afao.org.au/>
 - Aboriginal and Torres Strait Islander resources <https://www.talktesttreat.com.au/>
 - ASHM resources, including *Decision making in HIV* <https://www.ashm.org.au/resources>

1. May present with^{1,2}

- Positive HIV test
- At risk of HIV eg men who have sex with men (MSM); sexual partners of HIV infected people (unless HIV positive person has undetectable viral load); from country with high rates of HIV, people who inject drugs
- Potential exposure to HIV
- Possible HIV infection:
 - acute infection - flu, fever, rash, lymphadenopathy, sore throat, muscle aches, diarrhoea¹
 - unexplained immunosuppression eg oral thrush, herpes zoster, diarrhoea, weight loss, pneumonia, Kaposi sarcoma, skin infections²

2. Immediate management Not applicable

3. Clinical assessment

- **Testing for HIV¹**
 - get informed consent as with any other pathology test, including type of test, reasons for testing and potential implications of not being tested
 - a detailed history is not necessary
 - ensure confidentiality and anonymous testing if possible
 - advise when and how patient will get results

HIV blood tests²

Test	Consideration
HIV Ag/Ab	Reactive - may be positive for HIV, but needs confirmation 'true positive' ¹ Non reactive - negative for HIV. If exposed to HIV, retest after 12 weeks (window)
Western blot	Confirmatory test
HIV p24 antigen	High during HIV primary illness
CD4 lymphocyte	Marker of immune function, usually > 500
HIV RNA (viral load)	Marker of HIV level in serum, should be undetectable if on treatment

4. Management

- The clinician who ordered the test is responsible for following up results

Negative HIV test - if exposed to HIV, advise retest after window period of 12 weeks¹

Positive HIV test^{1,2}

- Get advice from local Sexual Health Service/HIV Public Health team **before** advising patient:
 - if person has done an HIV ‘self-test’ (or a ‘rapid test’ done) and is reactive, do HIV serology to confirm
 - check the result is confirmed as a **true positive** - check with lab
 - **results should be given in person (if possible) by a clinician experienced in HIV who will:**
 - concurrently offer HIV support/counselling
 - offer/start immediate treatment (ART)⁵- to be prescribed by s100 MO/NP
 - order bloods - CD4, HIV viral load, CHEM20, glucose, lipids, hep A²
 - urinalysis + other **STI/BBV tests, p. 448**
 - screen for **TB, p. 255**
 - arrange follow up within a few days to see how patient is coping¹ + refer for counselling/give continued support
 - refer for HIV specialist care¹
 - advise/assist contact tracing and management of contacts

Post-Exposure Prophylaxis (PEP)⁴

- PEP is to reduce risk of HIV after exposure to blood or bodily fluids
- **Immediately after exposure** advise:⁴
 - if wounds/skin exposed, wash with soap and water; if eyes/mucous membranes, irrigate with water (remove contact lenses); do not douche vagina/rectum after sexual exposure; if oral exposure, spit out and rinse mouth with water
- **Assess if PEP may be recommended:**
 - unprotected anal or vaginal sex/condom breakage OR shared injecting equipment with:
 - HIV positive person (not if sexual contact has undetected viral load)
 - person at higher risk of HIV eg MSM
 - person from high HIV prevalent country. See <http://aidsinfo.unaids.org/>
 - perpetrator(s) of sexual assault - particularly if by multiple people of unknown HIV status⁴
 - **work related exposure** with HIV positive person eg needle stick injury, blood/body fluids
 - if HIV status of source not known, attempt to get urgent HIV test - this should not delay PEP
- **If PEP indicated/unsure:**
 - promptly consult MO/NP with expertise in HIV eg sexual health/infectious disease MO, who may:
 - **risk assess** ± order PEP. **If ordered, start as soon as possible after exposure** (within 72 hours)
 - 3 day starter pack should be in clinic (course is 4 weeks)
 - advise pregnancy test + order baseline bloods - HIV (Ab, Ag) LFT, EU + **STI/BBV tests, p. 448**
 - order follow up bloods
 - **if work related exposure** - source is usually able to be identified and tested for HIV. PEP may be prescribed immediately if definite exposure or if source is at high risk of being HIV positive and unable to be tested immediately⁴
- For more information see PEP guidelines <http://www.pep.guidelines.org.au/>

Pre-Exposure Prophylaxis (PrEP)³

- Recommended for people at risk of HIV transmission:
 - advise to discuss with MO/NP for prescription - can take regularly or ‘on-demand’
 - need HIV testing 3 monthly while taking
 - for more information see PrEP guidelines <https://prepguidelines.com.au/>

5. Follow up²

- If HIV diagnosis, will require:
 - close follow up - within a few days to check wellbeing + as needed
 - long-term regular reviews by MO/NP experienced in HIV, in collaboration with usual MO/NP
 - support to adhere to long-term medications as needed
- As needed, see *HIV Monitoring tool (new patient + ongoing patient review)* <https://www.ashm.org.au/resources>

6. Referral/consultation²

- HIV is notifiable (laboratory will notify) ⓘ
- Refer to social worker/psychologist as needed for ongoing counselling. For further information see *Australian standards for psychological support for adults with HIV* <https://www.ashm.org.au/resources/hiv-resources-list/australian-standards-psychological-support-adults-hiv/>

Paediatrics

Paediatric presentation

History and physical examination - child

Recommend^{1,2}

- Pay particular attention to history from parent/carer
- Regardless of the time (day or night) or circumstances, reassure the parent/carer has done the right thing bringing the child in - **for any** concern
- If you have concerns for the safety and wellbeing of a child, see [Child protection, p. 551](#)
- Consult MO/NP for all children < 3 months of age
- **Consider serious illness if:**
 - infant < 3 months with T ≥ 38
 - child 3–6 months with T ≥ 39
 - rigors, low T < 36
 - unexplained pain/restlessness
 - drowsiness/decreased activity
 - looks sick/toxic
 - not waking easily
 - poor feeding in infants
 - nasal flaring, grunting, indrawing of chest
 - dry mucous membranes, reduced skin turgor
 - not responding normally to social cues
 - reduced urine output (no urine for ≥ 12 hours)
 - cool extremities
 - pale/mottled/ashen/blue skin, lips or tongue
 - weak, high pitched or continuous cry
 - > 5 watery diarrhoea in 24 hours

Background^{1,2}

- Small children, especially young babies, get sick very quickly
- Parent/carer information sheets for common paediatric presentations <https://www.childrens.health.qld.gov.au/qpec-parent-info/>

Vital signs - child approximate normal values⁴

Age (years)	< 1	1–2	2–5	5–12	≥ 12
Heart rate (HR) (beats/minute)	110–160	100–150	95–140	80–120	60–100
Respiratory rate (RR) (breaths/minute)	30–40	25–35	25–30	20–25	15–20
Blood Pressure (BP) (systolic) ⁵ Note: see APSGN, p. 511 for BP tips in children + parameters for hypertension	70–90	80–95	80–100	90–100	100–120
Temperature (T) ¹	36–37.9				
O ₂ saturation (SpO ₂)	≥ 94%				
Conscious level (Alert, Voice, Pain, Unresponsive)	Alert				
Capillary refill time (CRT)	< 2 seconds				
Blood glucose level (BGL) ⁶	3–8				

Sepsis and button battery considerations - all children**Think could this be sepsis if:**²

- Signs of infection, including history/evidence of fever or hypothermia

PLUS ANY of the following

- Looks sick/toxic
- Parental and/or clinician concern
- Immunocompromised
- Altered behaviour or ↓ level of consciousness
- Age < 3 months

If any of the above, screen for Sepsis, p. 64

Be button battery aware^{7,8}

Consider **Button battery, p. 80** ingestion if any of the following:

- Battery missing, seen to be playing with battery (may deny ingestion)
- Gagging, gulp, cough or choking episode

Or, non-specific symptoms eg:

- Unexplained partial food refusal, poor feeding - may still take soft food/fluids
- Drooling or regurgitation
- Croup like cough
- Chest pain or grunting (may be due to chest pain in pre-verbal child)
- Fever/vomiting/signs of infection without clear focus
- Upper GI bleeding - melaena (black stools), vomiting blood (may mimic a nose bleed)

If not managed urgently, a swallowed button battery can burn a hole through the oesophagus into the aorta and cause fatal haemorrhage

Step 1: Obtain history of the presenting concern/problem⁹

- Get history in conjunction with examining the child
- In a sick child do a full assessment of all systems
- The history is the most powerful tool for identifying the diagnosis in most cases

History of presenting concern/problem ^{9,10}	
Presenting concern/ problem	<ul style="list-style-type: none"> • Ask the parent/carer what the problem is • Listen to the carer: <ul style="list-style-type: none"> – particularly regarding changes in usual behaviour² – children can sometimes pep up on presentation • Use open ended questioning
For each symptom ask about (as relevant) Use SOCRATES mnemonic	<ul style="list-style-type: none"> • Site - where is the pain/symptom • Onset: <ul style="list-style-type: none"> – gradual/sudden – continuous/intermittent – what were they doing when it started • Character eg sharp, dull or burning • Radiation of pain or discomfort • Alleviating factors - what makes it better eg sitting up, medicines • Timing - when did it first begin, how long did it last, have they had it before • Exacerbating factors - does anything make it worse eg movement • Severity - mild, moderate or severe pain: <ul style="list-style-type: none"> – see Acute pain, p. 32 for pain assessment tools
Associated/other symptoms	<ul style="list-style-type: none"> • eg nausea, vomiting (+ colour eg coffee ground/blood/bile [green], yellow), photophobia, headache • Ask specifically about fever, pain, SOB/rapid breathing, diarrhoea, weight loss, rash • Be aware of vomiting without diarrhoea
Behaviour and activity during this illness	<ul style="list-style-type: none"> • Active/alert, sleepy or irritable, easy/difficult to wake • Muscle tone normal or are they floppy
Appetite and fluid intake/output during this illness	<ul style="list-style-type: none"> • How much do they normally drink eg 180 mL x 6 bottles/day • Intake now - try to be as precise as possible with quantities. How: <ul style="list-style-type: none"> – many drinks/breastfeeds – alert during feeds – long between intake and vomit/diarrhoea – many wet nappies/times passed urine in last 24 hours • Amount/type of bowel movements • Any blood in stool or change in bowel habits
Treatment ± medicine given by carer during this illness	<ul style="list-style-type: none"> • What, how much, when, how often, effectiveness • Any ibuprofen or paracetamol containing medicines given
<ul style="list-style-type: none"> • Ask if there are any other concerns • Consider possible differential diagnosis • Subsequently use closed ended questions to confirm or refute your differential diagnoses 	

Step 2: Ask about past history⁹⁻¹¹

- Review + update past history in medical record each visit. As appropriate, check *My Health Record* <https://www.myhealthrecord.gov.au/>
- Consider relevant past history that may assist with differential diagnosis this visit
- Always ask about allergies, medicines and immunisations

Past history ⁹⁻¹²	
Past medical and surgical history	<ul style="list-style-type: none"> • If < 2 years - ask if birth was normal, term/preterm, any neonatal problems¹² • Any problems with growth and development • As appropriate - mother's alcohol, smoking, drug use during pregnancy • Significant illnesses in past • Ask about - diabetes, asthma/eczema/hay fever, epilepsy, acute rheumatic fever (ARF) or rheumatic heart disease (RHD) • Hospital admissions, operations, injuries - where, when, why • Is child immunocompromised eg: <ul style="list-style-type: none"> – diabetes, malnutrition, no spleen, Down syndrome, corticosteroids, chemotherapy¹³
Family and social history	<ul style="list-style-type: none"> • Health problems in the (biological) family - especially siblings + parents • Who looks after the child, what is the social situation, any mental health problems in carer(s), living conditions • Access to phone (that works/with credit) and car/transport + distance to clinic • Record name of person presenting with child + relationship to child • Household smokers • Recent contacts or trips away • If medicines are given, will there be any problems to take them
Medications Also see Best possible medication history, p. 560	<ul style="list-style-type: none"> • Regular and prn medicines - prescribed, complementary, alternative, bush medicines, over-the-counter, vitamins, probiotics: <ul style="list-style-type: none"> – generic name – dose, route, frequency, taken correctly – recently changed/course completed • May need to ask about other medicine(s) in the home the child may have taken
Allergies Adverse medication reactions	<ul style="list-style-type: none"> • Allergies/reactions + type of reaction (anaphylaxis, skin reaction, other) to: <ul style="list-style-type: none"> – medicines – other eg honey bee stings, sticking plaster, food – has adrenaline (epinephrine) autoinjector eg EpiPen® been used • Check: <ul style="list-style-type: none"> – for medical alert jewellery/accessories eg shoe tag, anklet, watch¹⁴ – medical records + document allergies/adverse reactions¹⁵
Immunisations¹⁶	<ul style="list-style-type: none"> • Check if up-to-date (documented evidence) • Offer opportunistic Immunisations, p. 554 as appropriate
Opportunistic health checks (offer or refer as appropriate)	<ul style="list-style-type: none"> • Check if due for routine health check • For age appropriate checks and screening tools, see the <i>Chronic conditions manual</i> https://www.health.qld.gov.au/rscu/clinical-manuals/chronic-conditions-manual-cm

Step 3: Do physical examination⁹

In a sick child

- A thorough and complete examination is required
- All of the child's clothing will need to be removed at some stage

In a child who is not sick

- Examine the relevant system first + proceed to further examination as guided by the history + your findings
- This is particularly important when examining children who often present with generalised signs and symptoms

Tips for examining children

- Use distraction techniques
- May be best done with the child on the carer's knee
- If the child is irritable perform the examination opportunistically ie do what you can when you can
- Leave the most disruptive parts until last eg ears + throat

Physical examination - child^{9-12,17,18}

General appearance	<ul style="list-style-type: none"> • Watch before you examine • Observe interaction between carer + child • Appearance: <ul style="list-style-type: none"> – do they look well or sick – alert or drowsy – Tone - moving around and active OR floppy/limp and listless – Interactiveness - reaching for toys/interacting, or disinterested in interacting/playing – Consolability - can child be comforted by the care giver – Look/gaze - does the child fix their gaze on a face or is there a glassy eyed stare – Speech/cry - strong + vigorous, weak, hoarse, high pitched • Work of breathing (WOB): <ul style="list-style-type: none"> – look - retractions, nasal flaring, gasping, ↑ RR – listen - audible wheeze, snoring, grunting, stridor • Circulation: <ul style="list-style-type: none"> – look at lips tongue and fingers - are they blue – compare lips and tongue colour to parents if unsure – skin colour - pink/pallor, mottling, cyanosis • Any neck stiffness - feel gently. Ask the older child to put their chin on their chest - if they can, they do not have neck stiffness • Do they look well nourished
Vital signs (all children who present)	<ul style="list-style-type: none"> • RR, HR, BP, T, SpO₂ • Conscious state - GCS/AVPU, p. 562 • Capillary refill time (< 2 seconds) • BGL if indicated eg altered level of consciousness, seriously ill <p style="text-align: center;">Document on age appropriate CEWT (Qld) or local EWARS Calculate score. Act on score if indicated</p>

Physical examination - child (continued)

<p>Weight Every presentation to clinic</p>	<ul style="list-style-type: none"> • Weigh all children - bare weight if < 2 years:¹² <ul style="list-style-type: none"> – compare against most recent weights – plot on growth charts appropriate for age + gender • If appropriate, also measure:¹² <ul style="list-style-type: none"> – length if < 2 years or height if > 2 years + able to stand – head circumference if < 2 years, or if indicated in older child
<p>Hydration</p>	<ul style="list-style-type: none"> • Any weight loss • Eyes - normal or sunken. Tears absent or present • Mouth and tongue - wet or dry • Skin turgor - pinch a loose piece of skin. Does it return to normal immediately or stay saggy • Fontanelle - normal or depressed: <ul style="list-style-type: none"> – depressed may indicate dehydration – bulging arises from raised intra-cranial pressure + usually indicates a serious illness • Also see Hydration assessment - child, p. 535
<p>Skin</p>	<ul style="list-style-type: none"> • Always check the whole body, particularly in a sick child • Inspect for: <ul style="list-style-type: none"> – rash - non-blanching, petechiae, purpura – colour - unusually pale, mottled or cyanotic – bruising, unexplained or unusual marks – signs of infection - redness, swelling or tenderness • Skin lesions or sores: <ul style="list-style-type: none"> – colour, shape, size, location, distribution on body – exudate eg clear, pus, bloody – any family members/close contact with similar lesions • Any palpable/tender lymph nodes in the neck, axilla and groin
<p>Cardiovascular system</p>	<ul style="list-style-type: none"> • Inspect skin colour: <ul style="list-style-type: none"> – pink, white, grey mottling. Compare the trunk with the limbs – any oedema - check hands, feet, shins, lower legs, face • Palpate/feel: <ul style="list-style-type: none"> – skin temperature - hot, warm, cool, cold, sweating. Compare the trunk with limbs – peripheral pulses - weak or strong – peripheral perfusion - 'blanch' the skin on a finger or toe for 5 seconds. Time how long it takes for the colour to return – central perfusion - as per peripheral perfusion, but blanch the skin over the sternum with your thumb • If trained in auscultation listen to heart sounds

Physical examination - child (continued)

<p>Respiratory system</p>	<ul style="list-style-type: none"> • Most information is gained through inspection • Inspect anterior/posterior chest for: <ul style="list-style-type: none"> – equal chest movement – ↑ WOB - use of accessory muscles, rib retraction/recession; nasal flaring; head bobbing • If age appropriate, can child talk continuously, only in words/sentences/ unable to talk at all • Measure RR over 1 minute - rhythm, depth and effort of breathing • Listen for extra noises - cough ± sputum, wheeze, stridor, grunt, snore, hoarse speech/cry • Auscultate air entry in both lung fields: <ul style="list-style-type: none"> – equal, adequate, decreased or absent – wheeze or crackles - on inspiration or expiration – note: transmitted sounds from the upper respiratory tract are very common in children and may mask other signs • Will the child lie flat
<p>Gastrointestinal/ reproductive systems</p>	<ul style="list-style-type: none"> • Inspect for: <ul style="list-style-type: none"> – scars, abdominal distension, hernias, bruising or other discolouration, prominent veins, obvious masses • Auscultate bowel sounds - present or absent • Palpate abdomen - if pain, palpate with extra care: <ul style="list-style-type: none"> – soft or firm – any obvious masses – tender to touch - identify which abdominal quadrant and exact area – any guarding/rigidity - even when the child is relaxed – any rebound tenderness - press down and take your hand away very quickly - is the pain greater when you do this • Percuss and feel for bladder • Check the testes in boys - are they both in the scrotum: <ul style="list-style-type: none"> – any redness, swelling or tenderness
<p>Nervous system</p>	<ul style="list-style-type: none"> • A brief assessment is all that is needed • Assess orientation to time, place and person if appropriate for child's age: <ul style="list-style-type: none"> – ask - name, age, location, time, date, year • Pupils - size, symmetry, reaction to light • Assess asymmetry of tone and power - compare each side of the face and limbs • If indicated, test touch sensation using cotton wool • Test finger nose coordination. If possible, observe child walking, looking around and using hands
<p>Musculoskeletal system</p>	<ul style="list-style-type: none"> • Any pain in limbs, joints or muscles • Check for range of motion in limbs, joints and muscles - active and passive • Any redness, pain, swelling, heat or laceration over or near a joint(s) • Observe gait • Consider ARF, p. 515 and Swollen/painful joint - child, p. 550

Physical examination - child (continued)

Ears, nose and throat	<p>Ears - see Ear assessment, p. 519 for detailed assessment</p> <ul style="list-style-type: none"> Inspect: <ul style="list-style-type: none"> pinna - any redness, swelling ear canal - any obvious swelling or redness to outer canal (if there is looking with an otoscope will be painful) Use otoscope to inspect: <ul style="list-style-type: none"> canal - any redness, swelling, discharge eardrum - normal, redness, dullness, bulging or retraction, fluid, bubbles, perforation, foreign bodies (insects/objects) Check behind the ear (mastoid) for redness, swelling, pain <p>Nose</p> <ul style="list-style-type: none"> Feel for facial swelling, pain Any discharge or obvious foreign body <p>Throat</p> <ul style="list-style-type: none"> Inspect: <ul style="list-style-type: none"> lips, buccal mucosa, gums, palate, tongue, throat tonsils - redness, enlargement, pus teeth and gums - condition
Eyes	<ul style="list-style-type: none"> If indicated, test Visual acuity, p. 278 of each eye (use age appropriate Snellen chart) Inspect: <ul style="list-style-type: none"> eyes and surrounding structures - any redness, discharge or swelling pupils - equal in size, regular in shape, reaction to light eye movements - ask the child to follow the movement of your finger See Eye assessment, p. 276 for detailed assessment
Urinalysis	<ul style="list-style-type: none"> Examine the urine if: <ul style="list-style-type: none"> child sick abdominal pain or urinary symptoms unexplained symptoms or signs vomiting of unknown cause Inspect the colour - is it normal, dark, blood stained (consider APSGN, p. 511) Does it smell normal Urinalysis Pregnancy test ± STI screen if reproductive age + appropriate to presentation (with parental consent if age appropriate)

Step 4: Consider differential diagnosis

- See [Differential diagnosis - child, p. 488](#) flowcharts to aid in decision making
- If unsure, collaborate with MO/NP

Step 5: Select *Health Management Protocol (HMP)* or *Clinical Care Guideline (CCG)*

- To guide further assessment and management
- Document the page number of the HMP/CCG referred to in the medical record

Step 6: Order/collect pathology if indicated

- If child is unwell enough to require a blood test beyond BGL + Hb **always consult an MO/NP** first to save unnecessary testing or for 'additional' blood collection for other tests that may be required
- RIPRN:¹⁹
 - may order pathology as per the PCCM
 - name + signature of the MO, NP or RIPRN must be on pathology form or follow local protocol for electronic ordering
 - if RIPRN orders pathology, they are responsible for following up the result
 - consult MO/NP if abnormal/concerned about results
- Other clinical staff may be able to request pathology if there is a local agreement in place between the director of the clinical unit and Pathology Queensland/local health service
- Write 'copy of report to...' RFDS/other collaborative health provider on the pathology form as appropriate
- Point of care testing is available in some facilities eg i-STAT
- See Pathology Qld for:
 - pathology test list
 - rural and remote pathology request forms
 - see <https://www.health.qld.gov.au/healthsupport/businesses/pathology-queensland/healthcare>
- If outside Qld refer to local pathology services

Step 7: Collaborate with MO/NP as needed

- Always consult MO/NP if you are not sure
- Have CEWT score completed
- Use [ISOBAR, p. 25](#) to guide your communication
- Check your local facility guidelines to find out who to contact - during and after hours:
 - see [Qld contacts, p. 24](#). **If in doubt call RSQ 1300 799 127 (Qld)**

Differential diagnosis - child**Recommend**

- The following flowcharts can be used to assist with differential diagnosis in a child
- They are not intended to be a replacement for clinical judgment, expertise or experience
- Always work within your individual scope and refer to a MO/NP as needed

Child with fever

Babies < 3 months of age with T ≥ 38 contact MO/NP urgently^{1,2}

Fever in most children < 5 years old has a viral cause. A careful assessment will identify focus of infection in most patients

Consult MO/NP if fever with no obvious source of infection, or at any time you are unsure

Clinical assessment performed

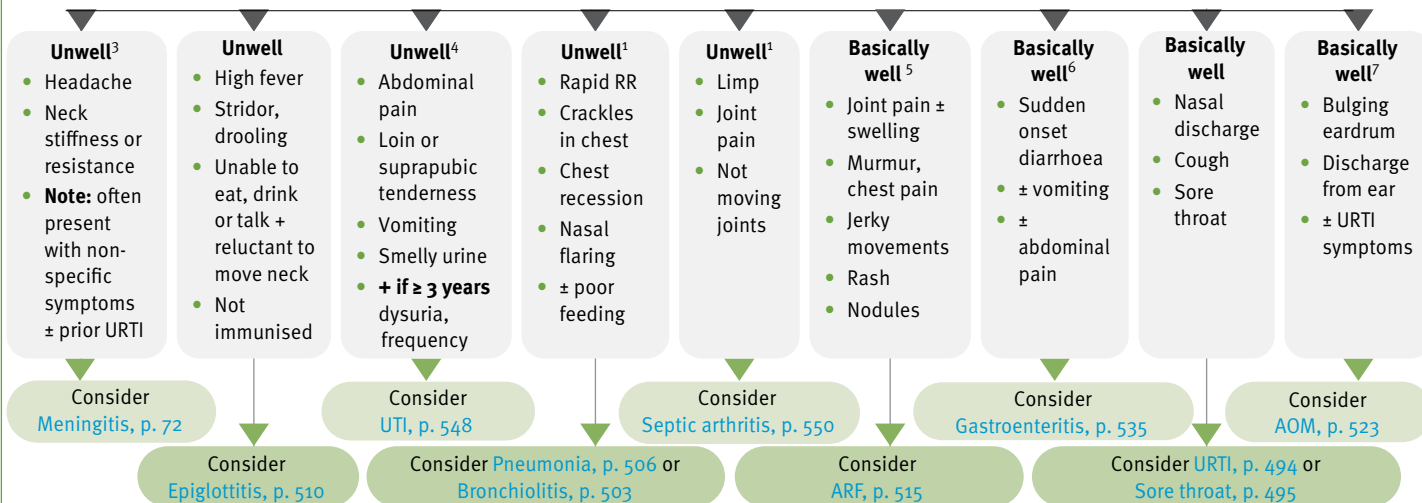

Always consider Sepsis, p. 64

Suspect febrile neutropenia if T ≥ 38.5 × 1 **OR** ≥ 38 × 2 an hour apart + chemotherapy in prior 2 weeks **OR** absolute neutrophil count (ANC) < 1 × 10⁹/L

Treating fever

Remove excess layers of clothing, but ensure child is not under-dressed. Do not tepid sponge. Encourage oral fluids if tolerated to maintain hydration

Consider paracetamol OR ibuprofen if child appears distressed (do not use with sole aim of reducing T)^{1,2}

Parent/carer fact sheet *Fever in children* <https://www.childrens.health.qld.gov.au/chq/information-for-families/fact-sheets/>

Child with cough

Babies < 3 months of age contact MO/NP urgently

Contact MO/NP if significant features of assessment unclear or you are unsure of cause

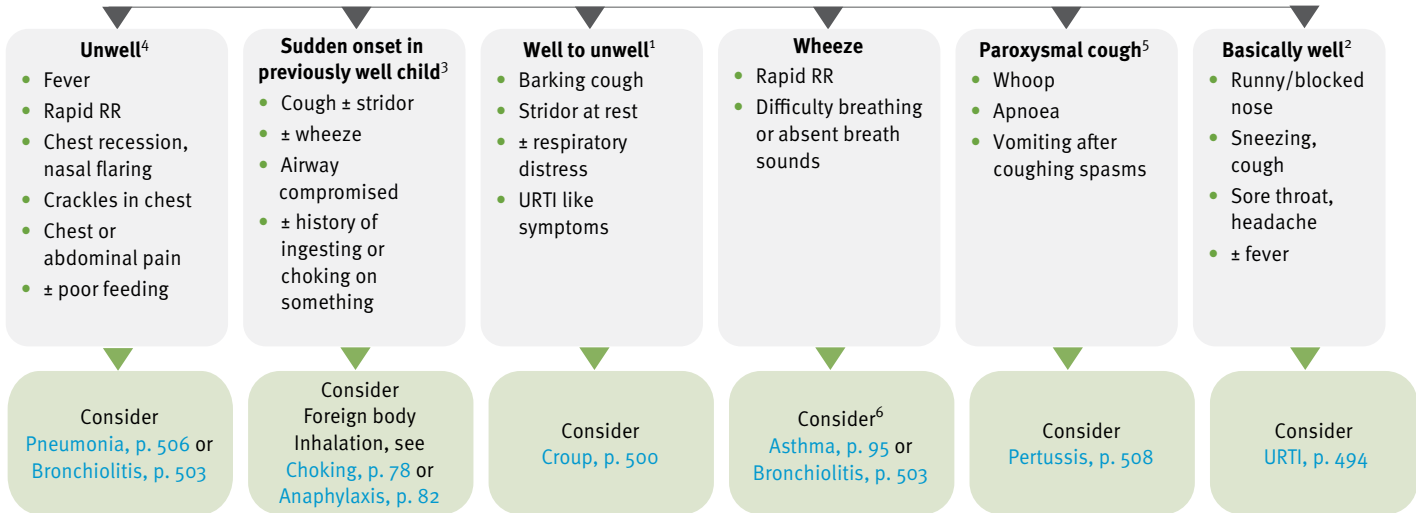
Clinical assessment performed

Always consider Sepsis, p. 64

Child with stridor

Contact MO/NP urgently

Stridor is a harsh vibrating sound occurring on inspiration due to upper airway obstruction

Consider causes: **croup** (common), **inhaled foreign body**, **epiglottitis** (rare but important), **trauma**, **angio-oedema**, **mass** (tumour or abscess)

Get rapid history, including Hib immunisation status. Limit examination. **Do not examine mouth or throat**

Significant features of assessment unclear or you are unsure of cause? **Yes** → Consult MO/NP **urgently**

No

Unwell¹

- High fever
- Drooling
- Unable to eat, drink or talk
- Reluctant to move neck
- Not immunised

Consider
[Epiglottitis, p. 510](#)

Well to unwell²

- Barking cough
- Stridor at rest
- ± respiratory distress
- URTI like symptoms

Consider
[Croup, p. 500](#)

Sudden onset in previously well child³

- Cough ± stridor
- ± wheeze
- Airway compromised
- Usually there is a history of ingesting or choking on something

Consider
Foreign body inhalation,
see [Choking, p. 78](#)

Acute onset in previously well child⁴ ±

- Swelling of tongue
- Swelling/tightness in throat
- Itchy rash (hives)
- Wheeze or persistent cough
- ± history of exposure to allergen eg:
 - food
 - bites/stings
 - medicine or blood product

Consider
[Anaphylaxis, p. 82](#)

Always consider [Sepsis, p. 64](#)

Child with vomiting

Babies < 3 months of age contact MO/NP urgently

Vomiting is a common and important symptom, which may indicate serious illness especially in a very young child. **Be aware of vomiting without diarrhoea.** Causes may include: **infection** (pneumonia, UTI, meningitis, AOM), **bowel obstruction** (pyloric stenosis, intussusception, appendicitis, hernia), **reflux oesophagitis**, **ICP** (trauma, abscess or tumour), **metabolic** (diabetic ketoacidosis, poisoning)

Clinical assessment performed

Significant features of assessment unclear or you are unsure of cause, or if bile or blood stained vomit → Yes → Consult MO/NP

No

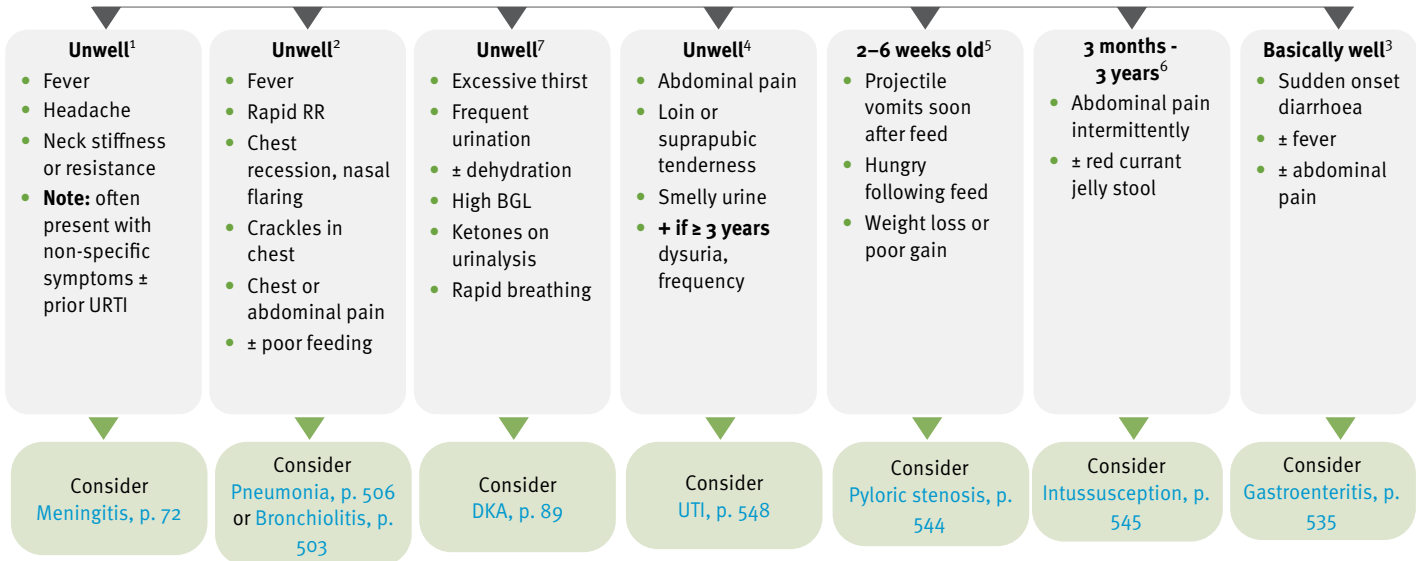

Also see Nausea and vomiting, p. 40. Always consider Sepsis, p. 64 and Button battery, p. 80

Child with abdominal pain

For any child with significant pain + babies < 3 months of age contact MO/NP urgently

Clinical assessment performed

Consult MO/NP if any of

- Bile or blood stained vomit
- Bloody stool
- Distension or guarding
- Localised or rebound tenderness
- Palpable mass, vomit looks/smells like faeces - consider [Bowel obstruction, p. 205](#)
- Inguinal-scrotal pain or swelling - **assume Testicular torsion, p. 209 until proven otherwise**
- Significant features of assessment unclear or **you are unsure of cause**

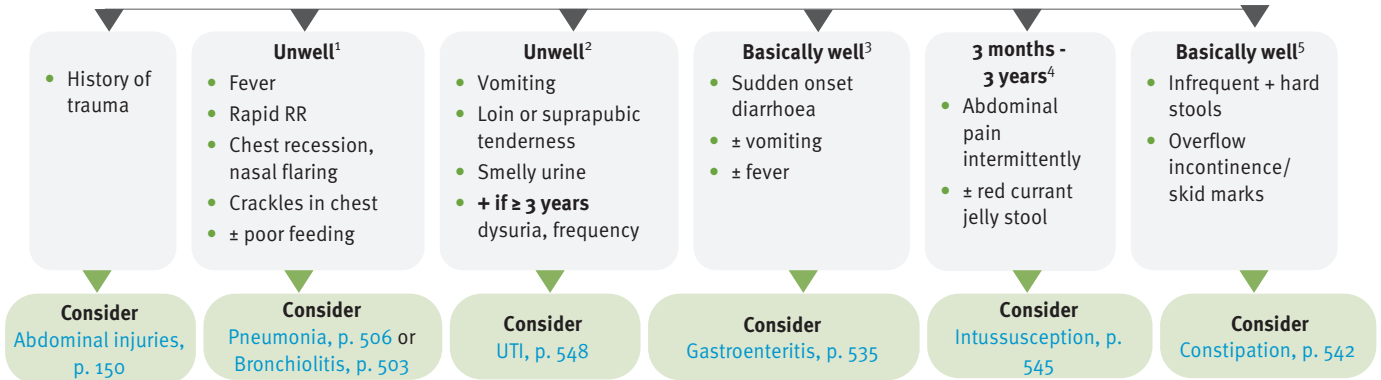

Also see [Abdominal pain, p. 196](#). Always consider [Sepsis, p. 64](#) and [Testicular torsion, p. 209](#)

Respiratory problems

HMP Upper respiratory tract infection (URTI) - child Common cold

Recommend

- Viral infection is the most likely cause and antibiotics are not recommended¹

Background

- Primary bacterial infection is uncommon, however secondary bacterial infection may develop¹

1. May present with²

- Runny/blocked nose
- Sneezing, cough
- Sore throat
- Headache
- Malaise ± fever

2. Immediate management Not applicable

3. Clinical assessment^{1,2}

- If < 12 months of age - consider [Bronchiolitis, p. 503](#) ask about:
 - lethargy
 - ↑ WOB, cough
 - how well are they feeding
- Ask about:
 - severe symptoms - T > 39 with purulent nasal discharge, facial pain¹
 - immunocompromised
- Do vital signs +
 - weight, if < 2 years bare weight
- Check:
 - chest - any:
 - ↑ WOB, respiratory distress:
 - accessory muscle use, abdominal breathing, inter/subcostal recession, tracheal tug
 - crackles or wheeze
 - ENT
 - neck stiffness
 - enlarged lymph glands

4. Management¹

- Consider differential diagnosis. See:
 - [Sore throat, p. 495](#)
 - [Child with fever, p. 489](#)
 - [Child with cough, p. 490](#)
 - [Child with stridor, p. 490](#)
- Contact MO/NP if symptoms are:
 - severe or respiratory distress

- worsening after initial improvement
- or persist > 7–10 days without improvement
- If mild symptoms and otherwise well:
 - reassure parent/carer that URTI is self-limiting and symptoms usually clear within 7 days
 - discuss symptomatic relief:¹
 - regular paracetamol or ibuprofen. See [Acute pain, p. 32](#)
 - frequent hand washing, nose blowing, sneeze and cough etiquette
 - do not use over-the-counter cough and cold medicines in children³

5. Follow up

- Advise to be reviewed if symptoms worsen or become severe:
 - consult MO/NP

6. Referral/consultation

- As above

HMP Sore throat - adult/child Pharyngitis, tonsillitis

Recommend^{1,2}

- Treat sore throats with antibiotics promptly in Aboriginal and Torres Strait Islander people living in rural + remote settings and in others who are at high risk of [ARF, p. 515](#) and [APSGN, p. 511](#)

1. May present with^{1,2}

- Sore throat
- Fever
- Difficulty swallowing
- Not eating/drinking as much
- Croaky voice

2. Immediate management²

- Look for symptoms of **airway obstruction/compromise** or **deep neck space infection** eg quinsy, including:
 - muffled voice, stridor, trismus (unable to open mouth)
 - drooling, neck swelling, torticollis (twisting of neck)
 - severe neck pain, respiratory distress
- If any of above, **urgently contact MO/NP** for **urgent evacuation** + airway management
- Do vital signs
- Screen for [Sepsis, p. 64](#)

3. Clinical assessment

- Get history, including:²
 - cough, fever, rash
 - feeding - normal or reduced intake, difficulty swallowing
 - times passed urine/number of wet nappies in last 24 hours
 - other symptoms eg diarrhoea, vomiting, headache, malaise, runny nose, red eyes, hoarse voice
 - past history of ARF, immunocompromised

- Do physical examination, including:
 - chest - listen for crackles/wheeze, air entry
 - throat/mouth - redness, swelling/pus on tonsils, ulcers/vesicles
 - ears
 - palpate neck for enlarged/tender lymph nodes
 - look for rash + signs of [APSGN, p. 511](#) and [ARF, p. 515](#)
- Use table below for **Differential diagnosis of sore throat**

Sore throat ²		
<ul style="list-style-type: none"> • No fever • Cough, hoarse voice • Conjunctivitis, nasal congestion • Red throat ± tonsils • ± rash, diarrhoea 	<p>Viral sore throat or tonsillitis</p> <p>Most common cause in all ages</p>	<p>Give antibiotics in all cases of sore throat if at high risk of ARF (see next page)</p> <ul style="list-style-type: none"> • Antibiotics not usually needed in general population • Symptomatic treatment • Can be difficult to tell if it is caused by a virus or Strep A - do a throat swab MCS to confirm
<ul style="list-style-type: none"> • Fever > 38 • Tender/swollen lymph nodes in neck • Red throat ± tonsils ± pus on tonsils • No cough, runny nose/congestion 	<p>Strep A sore throat or tonsillitis</p> <p>More common in school aged children and adolescents</p>	
Other presentations that may have a sore throat as a symptom ²		
Symptoms	Probable cause	Management
<ul style="list-style-type: none"> • Sudden fever > 38.5 • Followed by distinctive rash - red initially, then dry and rough with a 'sandpaper' feel • Facial flushing + white area around mouth • Tongue - white initially, then red and bumpy 'strawberry tongue' 	<p>Scarlet fever</p> <p>More common between 5–15 years</p>	<ul style="list-style-type: none"> • If suspected, consult MO/NP • MO/NP may advise to treat with antibiotics
<ul style="list-style-type: none"> • Fever, nausea • Severe sore throat • Swollen lymph nodes, swollen spleen/liver • Rash, fatigue 	<p>Epstein-Barr virus³ (Glandular fever)</p> <p>Common in adolescents and young adults</p>	<ul style="list-style-type: none"> • If suspected, consult MO/NP • Epstein-Barr virus serology • Symptomatic treatment • Lasts 2–3 weeks, fatigue sometimes for months
<ul style="list-style-type: none"> • Vesicles or ulcers in mouth and throat • Rash ± vesicles on hands and feet • ↓↓ appetite, malaise 	<p>Hand, foot and mouth disease⁴</p> <p>Common in children < 10 and family/school contacts with infection</p>	<ul style="list-style-type: none"> • If suspected, consult MO/NP • Symptomatic treatment • Usually resolves within 7 days • Advise to return daily until improved
<ul style="list-style-type: none"> • Fever > 38.5, malaise • Vesicles or ulcers in mouth and throat • Swollen lymph nodes in neck • Headache, abdominal pain, vomiting, ↓↓ appetite 	<p>Herpangina (mouth blisters)⁴</p> <p>More common < 5 years</p>	
<p>Non-infectious causes eg Allergic rhinitis, p. 248, rhinosinusitis, smoke, dry air</p>		

4. Management^{1,2}

- Contact MO/NP if:
 - < 1 year of age
 - unable to drink/signs of dehydration
 - $T \geq 39$
 - looks sick, not alert or interactive when T reduced
 - rash or signs of ARF/APSGN
 - immunocompromised
- Use flowchart below to determine if antibiotics are indicated or not for ‘sore throat’

Antibiotic indications for sore throat¹

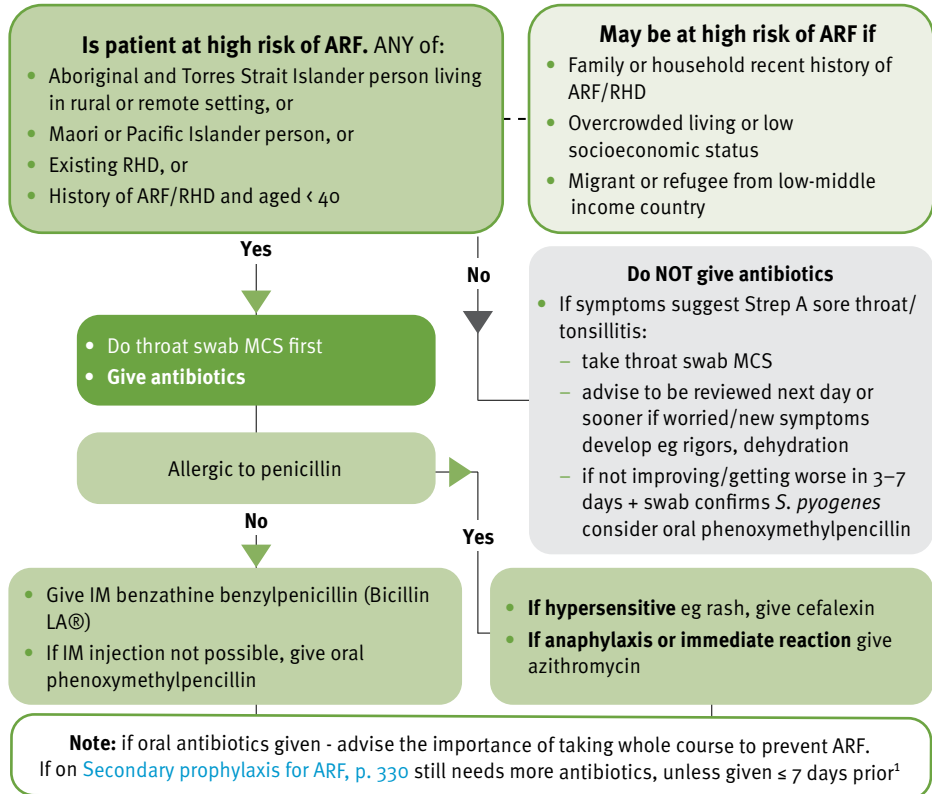

Symptomatic treatment of sore throat⁵

- Paracetamol or ibuprofen for pain and fever. See [Acute pain, p. 32](#)
- Throat lozenges for adolescents/adults²
- Drink plenty of water, avoid sugary drinks
- Keep away from smoke, get plenty of rest

S4	Benzathine benzylpenicillin (Bicillin LA®)					Extended authority ATSIHP/IHW/IPAP/RIPRN
ATSIHP, IHW, IPAP and RN must consult MO/NP						
RIPRN may proceed						
Form	Strength	Route	Dose			Duration
Prefilled syringe	1.2 million units/ 2.3 mL	IM	< 10 kg	450,000 units	0.9 mL	stat
			10– < 20 kg	600,000 units	1.2 mL	Inject slowly over at least 2–3 minutes
			≥ 20 kg	1.2 million units	2.3 mL	
Offer CMI: May cause diarrhoea, nausea and pain at injection site						
Note: Ventrogluteal , p. 564 or vastus lateralis sites preferred. Do not give in deltoid. See Managing injection pain , p. 563						
Contraindication: Severe or immediate allergic reaction to a penicillin. Be aware of cross-reactivity between penicillins, cephalosporins and carbapenems						
Management of associated emergency: Consult MO/NP. See Anaphylaxis , p. 82						1,6

S4	Phenoxymethylpenicillin			Extended authority ATSIHP/IHW/IPAP/RIPRN
ATSIHP, IHW, IPAP and RN must consult MO/NP				
RIPRN may proceed				
Form	Strength	Route	Dose	Duration
Capsule	250 mg 500 mg	Oral	Adult 500 mg bd	10 days
Oral liquid	125 mg/5 mL 250 mg/5 mL		Child 15 mg/kg (max. 500 mg) bd	
Offer CMI: May cause diarrhoea, nausea or thrush. Food has little effect on absorption				
Contraindication: Severe or immediate allergic reaction to a penicillin. Be aware of cross-reactivity between penicillins, cephalosporins and carbapenems				
Management of associated emergency: Consult MO/NP. See Anaphylaxis , p. 82				2,7

S4	Cefalexin			Extended authority ATSIHP/IHW/IPAP/RIPRN
ATSIHP, IHW, IPAP and RN must consult MO/NP				
RIPRN may proceed				
Form	Strength	Route	Dose	Duration
Capsule	250 mg 500 mg	Oral	Adult 1 g bd	10 days
Oral liquid	250 mg/5 mL		Child 25 mg/kg (max. 1 g) bd	
Offer CMI: May cause rash, diarrhoea, nausea, vomiting, dizziness, headache or thrush				
Note: If renal impairment seek MO/NP advice				
Contraindication: Severe or immediate allergic reaction to a cephalosporin or a penicillin. Be aware of cross-reactivity between penicillins, cephalosporins and carbapenems				
Management of associated emergency: Consult MO/NP. See Anaphylaxis , p. 82				1,2

S ₄	Azithromycin			Extended authority ATSIHP/IHW/IPAP/RIPRN
ATSIHP, IHW, IPAP and RN must consult MO/NP				
RIPRN may proceed				
Form	Strength	Route	Dose	Duration
Tablet	500 mg	Oral	Adult 500 mg daily	5 days
Oral liquid	200 mg/5 mL		Child 12 mg/kg (max. 500 mg) daily	
Offer CMI: May cause rash, diarrhoea, nausea, abdominal cramps or thrush				
Management of associated emergency: Consult MO/NP. See Anaphylaxis, p. 82				2,8

5. Follow up

- Check results of throat MCS if taken
- Advise to be reviewed the next day, or earlier if worried, symptoms worsen or new symptoms develop eg vomiting, dehydration, fever, rigors:²
 - contact MO/NP if not improving
- If at high risk of ARF:
 - provide education on signs and symptoms of ARF and APSGN, which can occur about 10 days to 2 weeks after sore throat or skin sores

6. Referral/consultation

- As above

HMP Croup - child

Background¹

- Croup usually develops over a few days with concurrent URTI like symptoms
- It is a viral inflammation and swelling of the upper airway, which can lead to obstruction
- Also see *Croup - emergency management in children* <https://www.childrens.health.qld.gov.au/qpec-statewide-guidelines/>

1. May present with¹

- Barking cough
- Inspiratory stridor, hoarseness of voice
- ± respiratory distress:
 - accessory muscle use, abdominal breathing, inter/subcostal recession, tracheal tug
- URTI like symptoms

2. Immediate management^{1,2}

- **Always consider differential diagnosis¹** eg Foreign body inhalation, [Button battery, p. 80](#), [Pertussis, p. 508](#), [Bronchiolitis, p. 503](#), [Epiglottitis, p. 510](#)

Assess severity of croup

- Avoid distressing child as may increase symptoms. Nurse child upright on parent/carer's lap

Mild	Moderate	Severe
<ul style="list-style-type: none"> • Occasional barking cough • No audible stridor at rest • No or mild respiratory distress at rest • SpO₂ ≥ 94%, no cyanosis • Alert 	<ul style="list-style-type: none"> • Frequent barking cough • Audible stridor at rest • Moderate respiratory distress • SpO₂ ≥ 94%, no cyanosis • Little or no agitation 	<ul style="list-style-type: none"> • Persistent stridor at rest (may be expiratory) • Severe respiratory distress • SpO₂ ≤ 93% or cyanosis • Fatigue or altered mental state

Continue as per **Clinical assessment**

Do vital signs + **reassess severity**
at least every 15 minutes
Is stridor persistent or ↑ WOB

No

Yes

Observe for minimum 4 hours

- Consult MO/NP urgently if symptoms persist or worsen
- Ongoing management as per MO/NP

Contact MO/NP urgently

- Who may order/arrange:
 - repeat adrenaline (epinephrine) NEB
 - urgent evacuation
- Monitor closely until evacuation

Give O₂ without causing distress

- Consider using O₂ tubing held near nose/mouth - 10 L/minute
- **Contact MO/NP urgently** who may order:
 - adrenaline (epinephrine) NEB +
 - prednisolone 2 mg/kg (max. 50 mg)

3. Clinical assessment¹

- Get history, including:
 - fever
 - airway symptoms - getting worse, worse at night
- Do physical examination, including:
 - vital signs
 - check for any:
 - changes in WOB
 - audible stridor
 - chest wall movement eg cave in during inspiration
 - paradoxical breathing - may indicate fatigue
 - weight - bare weight if < 2 years
- **Do not examine throat** as distress may exacerbate symptoms
- Assess for **Risk factors for severe croup¹**

Risk factors for severe croup¹

- < 6 months of age
- Structural upper airway condition eg tracheomalacia
- Previous severe croup
- Unplanned re-presentation < 24 hours of first croup presentation
- Down syndrome

4. Management¹

- If any risk factors, contact MO/NP promptly
- In all cases:²
 - minimise handling, keep the child calm eg sitting quietly, reading or watching TV
 - keep the child with parents/carers to ↓ distress
 - allow the child to adopt a position of comfort that minimises airway obstruction
 - reassure and educate parents/carers on the cause, usual course and management to ↓ anxiety
 - give croup fact sheet eg <https://www.childrens.health.qld.gov.au/fact-sheet-croup/>

Mild or moderate croup:

- Contact MO/NP who may advise:
 - oral prednisolone OR budesonide NEB if not tolerating oral^{1,2}
- Continue to observe for at least 1 hour post corticosteroids¹
- Reassess severity and response to treatment
- If stridor persists or ↑ WOB contact MO/NP:
 - who may order adrenaline (epinephrine) NEB as per severe croup¹
- If symptoms settle:
 - consult MO/NP who may consider sending patient home if stridor free at rest 1 hour after corticosteroids **or 4 hours after adrenaline (epinephrine) if this has been required¹**

S3	Adrenaline (epinephrine)			Extended authority ATSIHP/IHW/IPAP
ATSIHP, IHW and IPAP must consult MO/NP				
RIPRN and RN must consult MO/NP unless circumstances do not allow, in which case proceed for severe group and notify MO/NP as soon as circumstances allow				
Form	Strength	Route	Dose	Duration
Injection	1:1,000 1 mg/mL	NEB with O ₂ 8 L/minute	5 mL (5 mg) undiluted	stat Repeat after 30 minutes if no improvement
Offer CMI: May cause restlessness, anxiety, headache or palpitations				
Management of associated emergency: Consult MO/NP 1-4				

S4	Prednisolone			Extended authority ATSIHP/IHW/IPAP
ATSIHP, IHW, IPAP, RIPRN and RN must consult MO/NP				
Form	Strength	Route	Dose	Duration
Oral liquid	5 mg/mL	Oral	Child > 1 month 1–2 mg/kg (max. 50 mg)	stat
Offer CMI: May affect mood and sleep. Take with food to help reduce stomach upset				
Management of associated emergency: Consult MO/NP. See Anaphylaxis, p. 82 1,2,5,6				

S4	Budesonide			Extended authority ATSIHP/IHW/IPAP
ATSIHP, IHW, IPAP, RIPRN and RN must consult MO/NP				
Form	Strength	Route	Dose	Duration
Inhalation solution	0.5 mg/2 mL 1 mg/2 mL	NEB with O ₂ 8 L/minute	2 mg	stat
Offer CMI: May cause facial irritation. Cover eyes during NEB and wash face afterwards				
Management of associated emergency: Consult MO/NP. See Anaphylaxis, p. 82 1,2,7				

5. Follow up

- Advise to be reviewed the next day or sooner if symptoms recur
- Contact MO/NP if symptoms recur, who may consider other causes

6. Referral/consultation

- As above

Bronchiolitis - child

Background¹

- Bronchiolitis is a lower respiratory tract viral illness in infants < 12 months of age
- Also see *Bronchiolitis - emergency management in children* <https://www.childrens.health.qld.gov.au/qpec-statewide-guidelines/>

1. May present with¹

- Consider bronchiolitis if history of URTI followed by onset of **respiratory distress + fever and ≥ 1** of:
 - cough
 - tachypnoea
 - retractions
 - diffuse crackles or wheeze on auscultation
 - feeding difficulties

2. Immediate management

- Always consider differential diagnosis eg:¹
 - Sepsis, p. 64, Foreign body inhalation, Pneumonia, p. 506

Assess severity^{1,2}

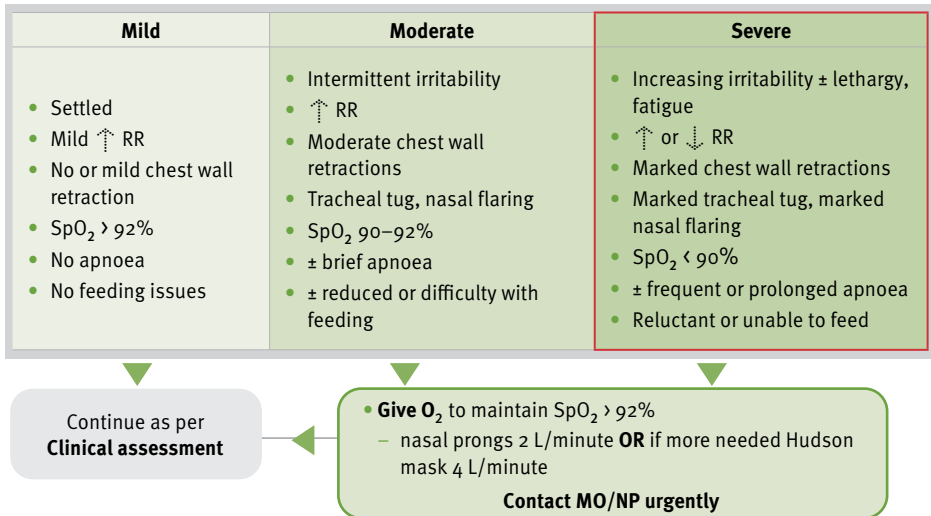

3. Clinical assessment¹

- Ask about:
 - recent URTI symptoms
 - feeding/hydration:
 - inadequate feeds eg < 50% of usual feeds over 12 hours
 - duration of feeds
 - number of wet nappies in last 24 hours

- Do:
 - vital signs
 - listen to chest for crackles or wheeze
 - check ears
 - bare weight
- Assess for **Risk factors for severe disease**¹

Risk factors for severe disease¹

- Born < 37 weeks
- < 10 weeks of age
- Underlying conditions eg congenital heart disease, Down syndrome, immunocompromised
- Aboriginal and Torres Strait Islander
- Failure to thrive
- Exposure to cigarette smoke
- Breastfed for < 2 months

4. Management

- Contact MO/NP in all cases, urgently if moderate-severe

Moderate-severe cases^{1,2}

- Require urgent evacuation
- Monitor closely until evacuation:
 - vital signs + WOB
 - SpO₂
 - discontinue O₂ if SpO₂ persistently > 92%
 - **note:** brief ↓ SpO₂ < 92% does not require O₂
- **Do NOT give** corticosteroids, adrenaline (epinephrine) or nebulised hypertonic saline^{1,3}
- Only give salbutamol on MO/NP advice
- High flow nasal cannula (HFNC) oxygen therapy can only be initiated if < 24 months of age following consultation with paediatrician at a Level 4 facility or retrieval services who will consult paediatrician:⁴
 - HFNC should not be used if > 24 months of age^{2,4}
 - if receiving HFNC should be immediately evacuated
- Support parent/carer to offer small frequent feeds:^{1,2}
 - if feeding inadequately MO/NP may consider NG or IV hydration

If mild symptoms

- If mild with risk factors, further observation/hospitalisation may be required¹
- Consider sending home in consultation with MO/NP if:^{1,2}
 - able to maintain SpO₂ in room air
 - feeding adequately
 - parent/carer can safely manage infant at home eg consider time of day, parent/carer understanding of condition, access to clinic
- Provide **Advice to parents/carers** before sending home^{1,2}

Advice to parents/carers^{1,2}

- Most children are back to normal within 7–10 days. Cough may last up to 1 month
- Bring your child back if you are worried or if any:
 - trouble with feeding and fewer wet nappies than usual
 - difficulty breathing
 - very sleepy, becomes pale or sweaty or begins to look blue in the skin
 - pauses between breaths
- Make sure your child is getting enough fluids. Smaller feeds given more often may help
- Paracetamol may help if child looks uncomfortable
- Keep child away from smoke
- Prevent spread of infection by:
 - keeping your child away from other small children for the first few days of illness
 - washing your hands frequently

5. Follow up

- If not evacuated advise to be reviewed the following day or earlier if concerned:
 - consult MO/NP if not improving

6. Referral/consultation

- As above

HMP Pneumonia - child

Recommend

- Children with severe pneumonia living north of Mackay, Tennant Creek and Port Hedland, require a different antibiotic regimen during the wet season to cover for melioidosis¹

Background

- Viruses are the most common cause in children > 2 months¹

1. May present with²

- Fever, cough
- Looks unwell
- ↑ RR
- ↑ WOB - use of accessory muscles eg:
 - tracheal tug
 - subcostal and intercostal recession (indrawing between or under the ribs)
 - infants may have nasal flaring, grunting, head bobbing, episodes of apnoea

2. Immediate management^{1,2}

- Do vital signs
- **Screen for Sepsis, p. 64**
- Rapidly assess severity as per table below

Assess severity

Mild	Moderate	Severe
<ul style="list-style-type: none"> • No or mild ↑ WOB • RR normal or mild ↑ • SpO₂ ≥ 95% • HR normal • Alert² • Feeding normally 	<ul style="list-style-type: none"> • Moderate ↑ WOB • ↑ RR • SpO₂ ≤ 95% • ↑ HR • Capillary refill ≥ 3 seconds 	<ul style="list-style-type: none"> • Severe ↑ WOB • ± grunting/nasal flaring/apnoea¹ • Marked ↑ RR ± exhaustion • SpO₂ ≤ 90% • ↑ HR • Capillary refill ≥ 3 seconds

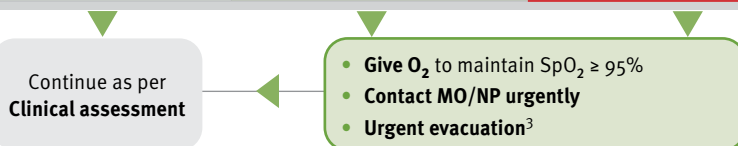

3. Clinical assessment²

- Also consider other diagnoses eg [Bronchiolitis, p. 503](#), [URTI, p. 494](#)
- **Get rapid history**, including:
 - rapid breathing, apnoea
 - cough
 - pleuritic pain (sharp chest pain) in older child
 - abdominal pain²
 - fever
 - feeding - normal or reduced intake/ability to feed

- times passed urine/number of wet nappies in last 24 hours
- vomiting, diarrhoea
- recent infections eg bronchiolitis
- recent travel
- Do physical examination, including:
 - listen to chest for any crackles, wheeze
 - [Hydration assessment - child, p. 535](#)
 - check:
 - ENT
 - skin for rash
- Assess for risk factors for severe pneumonia eg:²
 - born < 37 weeks
 - immunocompromised
 - underlying conditions eg chronic lung disease, cardiopulmonary disease, cancer

4. Management

- Contact MO/NP in all cases, **urgently if moderate–severe or < 3 months of age:**
 - if < 2 months treat as per [Sepsis, p. 64](#)¹

Moderate–severe pneumonia²

- Arrange urgent evacuation³
- If unable to maintain $\text{SpO}_2 \geq 95\%$ **consult MO/NP urgently**
- Monitor closely until evacuation:
 - vital signs + WOB
- MO/NP may order:
 - oral amoxicillin or IV/IM antibiotics:
 - if allergy to penicillins - MO/NP will advise
 - chest x-ray, bloods, blood cultures²
- If not tolerating oral fluids, MO/NP may consider NG or IV fluids
- Offer paracetamol for discomfort of fever or pain. See [Acute pain, p. 32](#)

Mild pneumonia

- MO/NP may order:
 - oral amoxicillin:
 - if allergy to penicillins - MO/NP will advise
- If mild with risk factors for severe pneumonia, further observation/hospitalisation may be required²
- Consider sending home in consultation with MO/NP if:²
 - normal RR + HR
 - able to maintain $\text{SpO}_2 \geq 95\%$ in room air
 - feeding adequately
 - parent/carer can safely manage infant at home eg consider time of day, parent/carer understanding of condition, access to clinic
- Provide **Advice to parents/carers** before sending home²

S4	Amoxicillin			Extended authority ATSIHP/IHW/IPAP
ATSIHP, IHW, IPAP, RIPRN and RN must consult MO/NP				
Form	Strength	Route	Dose	Duration
Capsule	250 mg 500 mg	Oral	Child > 2 months 25 mg/kg (max. 1 g) tds	5–7 days
Oral liquid	250 mg/5 mL 500 mg/5 mL			
Offer CMI: May cause rash, diarrhoea, nausea or thrush				
Contraindication: Severe or immediate allergic reaction to a penicillin. Be aware of cross-reactivity between penicillins, cephalosporins and carbapenems				
Management of associated emergency: Consult MO/NP. See Anaphylaxis, p. 82				1,4

Advice to parents/carers²

- Most children usually improve within 1–2 days of starting antibiotics, although they may cough for a few days/weeks
- Bring your child back if you are worried or if any:
 - vomiting and are unable to drink much
 - difficulty breathing
 - very sleepy, becomes pale or sweaty, or begins to look blue in the skin
 - pauses between breaths
- Make sure your child is getting enough fluids. Smaller feeds given more often may help
- Paracetamol may help if child looks uncomfortable

5. Follow up

- If not evacuated advise to be reviewed next day, or earlier if concerned:
 - consult MO/NP if not improving
- Advise to see MO/NP at next clinic

6. Referral/consultation

- As above

HMP Pertussis - adult/child Whooping cough

Background

- Still prevalent - outbreaks occur every 3–4 years. Infants < 6 months at ↑ risk of complications¹

1. May present with

- Apnoea or cyanosis ± cough - may be only symptom in infants¹
- Intermittent violent uncontrollable coughing ± 'whoop' when breathing in¹
- Persistent cough up to 3 months, otherwise well^{1,2}
- Vomiting following coughing spasms²

2. Immediate management

- Do vital signs
- If SpO₂ ≤ 93%, cyanosis or apnoea:
 - give O₂
 - contact MO/NP urgently
- Use droplet PPE. If able, see patient away from main treatment room³

3. Clinical assessment^{1,3}

- **Ask about:**
 - cough - onset, persistent or getting worse, vomiting after coughing
 - similar illness in household contacts
 - vaccination status - patient + household contacts³
 - other symptoms
- **Check:**
 - WOB. Chest - listen for air entry, crackles, wheeze
 - weight - bare weight if < 2 years
- Take nasopharyngeal swab for pertussis PCR

4. Management

- Contact MO/NP promptly if:
 - young child or baby - even if mild symptoms
 - acutely unwell
- Advise Public Health Unit you suspect pertussis

If pertussis diagnosed

- Consult MO/NP + Public Health Unit, who may advise:
 - if ≤ 3 weeks of cough or other symptom onset give:²
 - azithromycin to patient and contacts (ie if been within 1 metre of patient for > 1 hour)²
- Advise patient/carer:³
 - highly infectious - spreads by coughing/sneezing + direct contact eg wiping nose, mouth
 - **stay away from others until antibiotics have been taken for 5 days**, especially:
 - children and babies, pregnant women, work, school, preschool or child care
 - cough can continue for a few weeks

S ₄	Azithromycin			Extended authority ATSIHP/IHW/IPAP/RIPRN
ATSIHP, IHW, IPAP, RIPRN and RN must consult MO/NP				
Form	Strength	Route	Dose	Duration
Tablet	500 mg	Oral	Adult 500 mg on day 1, then 250 mg daily Child ≥ 6 months 10 mg/kg (max. 500 mg) on day 1 THEN 5 mg/kg (max. 250 mg) daily Infant < 6 months 10 mg/kg daily	5 days
Oral liquid	200 mg/5 mL			
Offer CMI: May cause rash, diarrhoea, nausea, abdominal cramps or thrush				
Management of associated emergency: Consult MO/NP. See Anaphylaxis, p. 82				3:4

5. Follow up

- As per MO/NP:
 - if discharged home advise to return if symptoms worsen or they are concerned
 - follow up swab result

6. Referral/consultation

- Notify Public Health Unit of confirmed or suspected pertussis cases¹ ⓘ

Epiglottitis - child

Background¹

- Epiglottitis is a life-threatening inflammation of the epiglottis and surrounding area
- Since the *Haemophilus influenzae* type b (Hib) vaccine, epiglottitis is rare

1. May present with²

- High fever, looks sick
- Hyperextension of neck, may not move neck
- Drooling saliva, difficulty swallowing
- Stridor
- Restless, unsettled

2. Immediate management^{1,2}

- Patients with epiglottitis often have sepsis:
 - contact MO/NP urgently
 - urgent evacuation required
- See [Sepsis, p. 64](#) for further management, including urgent antibiotics:
 - ceftriaxone or cefotaxime
- Avoid distressing child as may exacerbate symptoms:
 - **do not examine throat**
 - allow child to settle in the position most comfortable
 - if O₂ required and mask distressing:
 - consider using O₂ tubing held near nose/mouth - 10 L/minute

3. Clinical assessment^{1,2}

- Assess as per [Sepsis, p. 64](#)
- Also look for drooling + absent cough with low pitched expiratory stridor (often snoring)

4. Management¹

- Manage as per [Sepsis, p. 64](#)

5. Follow up

- As per MO/NP instructions

6. Referral/consultation

- As above

Post streptococcal diseases

HMP Acute post streptococcal glomerulonephritis (APSGN) - adult/child

Recommend¹

- Aim to prevent APSGN by promoting:
 - early treatment of [Impetigo, p. 298](#) (skin sores) and [Sore throat, p. 495](#)
 - community control of scabies and skin sores
 - regular washing + hand hygiene, especially children

Background¹

- APSGN is an inflammatory kidney disease which occurs 2–3 weeks after a skin or throat infection with Group A *Streptococcus* (GAS), or occasionally groups C or G
- Common in Aboriginal and Torres Strait Islander children in Northern Australia in areas with high levels of scabies, skin sores and overcrowded living conditions
- Most common 2–17 years of age, but can occur at any age

1. May present with^{1,2}

- Microscopic haematuria detected on urinalysis
- Acute nephritis - **typical presentation**:
 - puffy face (facial oedema)
 - \geq moderate blood in urine on dipstick - urine can look smoky, tea/cola coloured
 - hypertension
 - peripheral oedema eg in legs/hands
 - proteinuria
- Skin sores/infected scabies OR recent history of skin sores or sore throat
- In severe cases of nephritis:
 - respiratory distress due to pulmonary oedema
 - lethargy, general weakness, anorexia
 - uncommon - severe headache, convulsions, coma

2. Immediate management

- If severe symptoms, urgently consult MO/NP

3. Clinical assessment^{1,2}

- Get history + ask about:
 - puffiness of face or eyes, legs or arms
 - urine colour
 - urine output - has it decreased
 - any other symptoms eg SOB, feeling unwell, off food
 - do any close contacts have similar symptoms
 - recent history of skin sores/infected scabies or sore throat (in prior 2–3 weeks)
 - previous medical history, including APSGN or close contacts with APSGN
- Do physical examination, including:¹
 - vital signs - use the table **BP requiring further evaluation in children** to determine if child is hypertensive. Do not rely on CEWT BP ranges

- urinalysis - check for blood and protein
- weight - bare weight if < 2 years. Assess against recent weights
- skin for sores/[infected scabies, p. 298](#)
- face, hands and feet for oedema/puffiness
- throat - any redness
- listen to chest for crackles or wheeze - may indicate pulmonary oedema

Take pathology¹

- **If symptoms of acute nephritis:**
 - if skin sores present - MCS swabs from 2 different sites. See [How to take a wound swab, p. 324](#)
 - if sore throat - MCS throat swab
 - bloods - ASOT, antiDNAase B titres, C₃, C₄, FBC, film, UE, LFT
 - urine for MCS and ACR
 - on the pathology form, include ‘suspected APSGN’
- **If microscopic haematuria but NO other symptoms + no history of APSGN in prior 6 months:**
 - urine for MCS and ACR

Diagnosis of APSGN ¹		
Possible APSGN	Requires <i>laboratory suggestive evidence</i> only	
Probable APSGN	Requires <i>clinical evidence</i> only	
Confirmed APSGN	Requires either <i>laboratory definitive evidence</i> OR <i>laboratory suggestive evidence AND clinical evidence</i>	
Clinical evidence	Laboratory suggestive evidence	Laboratory definitive evidence
At least 2 of the following: <ul style="list-style-type: none"> • Facial oedema • ≥ moderate haematuria on dipstick • Hypertension • Peripheral oedema 	Haematuria on microscopy (RBC > 10/uL) AND Evidence of recent GAS infection eg positive culture from skin or throat, or elevated ASO titre or Anti-DNase B AND Reduced C ₃ level	Renal biopsy suggestive of APSGN

BP requiring further evaluation in children ³				
If BP is LESS than the values on this table, then it is NOT elevated				
Age (years)	Boys		Girls	
	Systolic	Diastolic	Systolic	Diastolic
1	98	52	98	54
2	100	55	101	58
3	101	58	102	60
4	102	60	103	62
5	103	63	104	64
6	105	66	105	67
7	106	68	106	68
8	107	69	107	69
9	107	70	108	71
10	108	72	109	72
11	110	74	111	74
12	113	75	114	75
≥ 13-17	120	80	120	80

BP in children³

- Measure on right arm for consistency, with appropriately sized cuff
- Can vary considerably during the same visit or across visits. If initial BP ↑, do 2 more BP at same visit and average them
- Check against the **BP requiring further evaluation in children** table:
 - if BP is ≥ the values, also measure height
 - then go to *Clinical practice guidelines for screening and management of high blood pressure in children* <https://pediatrics.aappublications.org/content/142/3/e20181739>
 - check BP against table 4 (boys) or table 5 (girls)
 - a BP > 90th percentile is elevated
 - if unsure, consult MO/NP

4. Management^{1,3}

- **If microscopic haematuria found on urinalysis** but NO other symptoms:
 - if prior history of APSGN - haematuria can persist for up to 3–6 months post resolution¹
 - if there is no history of APSGN in last 6 months - advise to see MO/NP at next clinic
- **Consult MO/NP promptly if:**
 - any child with oedema or hypertension:
 - BP > 90th percentile is elevated and requires further investigation
 - BP > 95th percentile requires aggressive treatment
 - if hypertension ± heart failure, MO/NP may order furosemide (frusemide)
- **If ‘clinical evidence’ suggests probable APSGN** promptly consult MO/NP:¹
 - evacuation/hospitalisation required
 - give benzathine benzylpenicillin (Bicillin LA®):
 - if allergic to penicillin give oral trimethoprim + sulfamethoxazole⁴
 - treat *Scabies*, p. 316 if present
 - ask for close contacts from previous 2 weeks + adults and children staying in house
 - notify Public Health Unit for further advice on examining + management of contacts

S4		Benzathine benzylpenicillin (Bicillin LA®)				Extended authority ATSIHP/IHW/IPAP/RIPRN
ATSIHP, IHW, IPAP and RN must consult MO/NP						
RIPRN may proceed						
Form	Strength	Route	Dose			Duration
Prefilled syringe	1.2 million units/2.3 mL	IM	≤ 6 kg	300,000 units	0.6 mL	stat Inject slowly over at least 2–3 minutes
			6– < 12 kg	450,000 units	0.9 mL	
			12– < 16 kg	600,000 units	1.2 mL	
			16– < 20 kg	900,000 units	1.7 mL	
			≥ 20 kg	1.2 million units	2.3 mL	
Offer CMI: May cause diarrhoea, nausea and pain at injection site						
Note: <i>Ventrogluteal</i> , p. 564 or vastus lateralis sites preferred. Do not give in deltoid. See <i>Managing injection pain</i> , p. 563						
Contraindication: Severe or immediate allergic reaction to a penicillin. Be aware of cross-reactivity between penicillins, cephalosporins and carbapenems						
Management of associated emergency: Consult MO/NP. See <i>Anaphylaxis</i> , p. 82						1,4,5

S4	Trimethoprim + sulfamethoxazole		Extended authority ATSIHP/IHW/IPAP/RIPRN	
ATSIHP, IHW, IPAP and RN must consult MO/NP				
RIPRN may proceed				
Form	Strength	Route	Dose	Duration
Tablet	80 + 400 mg 160 + 800 mg	Oral	Adult 160 + 800 mg bd Child ≥ 1 month 4 mg/kg (max. 160 mg) bd	3 days
Oral liquid	40 + 200 mg /5 mL		<i>Dose as per trimethoprim component</i>	
Offer CMI: Take with food to reduce stomach upset. May cause fever, nausea, vomiting, diarrhoea, itch, rash or sore mouth. Avoid sun exposure. Report straight away if sore throat, fever, rash, cough, breathing difficulties, joint pain, dark urine or pale stools				
Note: If renal impairment, taking ACE inhibitor or potassium, HIV or SLE seek MO/NP advice				
Pregnancy: Do not use in the 1st trimester or in late pregnancy				
Contraindication: Severe or immediate allergic reaction to sulfonamides, megaloblastic anaemia, severe hepatic impairment				
Management of associated emergency: Consult MO/NP. See Anaphylaxis, p. 82				1,4,6

5. Follow up¹

- Follow up close contacts in collaboration with Public Health Unit
- Children with a history of APSGN should be monitored through an individualised care plan developed in conjunction with a paediatrician. Check care plan is in place and follow up anything outstanding
- Resolution of APSGN:
 - usually resolves quite rapidly assuming concurrent resolution of infection
 - haematuria can persist for up to 3–6 months
 - proteinuria may persist longer - mild increase sometimes up to 3 years or more

6. Referral/consultation

- Consult MO/NP for all suspected cases
- APSGN is notifiable in the NT ^{Q1}
- In Qld, APSGN is not notifiable, however, alert Public Health Unit

HMP Acute rheumatic fever (ARF) - adult/child

Recommend¹

- ARF should **always be considered in patients with sore ± swollen joint(s)** in populations at high risk of ARF, RHD or Group A Strep infections
- Aim to prevent ARF by promoting:
 - early treatment of [Impetigo, p. 298](#) (skin sores) and [Sore throat, p. 495](#)
 - community control of scabies and skin sores
 - regular washing + hand hygiene, especially children

Background¹

- ARF:
 - is an auto-immune response to an untreated infection with Group A Strep in the throat + the skin. It affects the heart, joints, skin + the nervous system
 - difficult to diagnose. Correct diagnosis is important so that people who do have ARF are correctly managed + those who do not have it avoid unnecessary treatment
 - peaks in children aged 5–14 years + adults 15–24, reducing substantially with age. Is rare > 35 years
- **High risk populations:**
 - Aboriginal and Torres Strait Islander people living in rural + remote areas
 - Maori + Pacific Islander people, migrant groups
 - previous history of ARF/RHD and aged < 40
- **Recommended resources:**
 - *The 2020 Australian guideline for prevention, diagnosis and management of acute rheumatic fever and rheumatic heart disease* (3rd ed) <https://www.rhdaustralia.org.au/resources>
 - *ARF & RHD guideline app* <https://www.rhdaustralia.org.au/apps> + [Diagnosis calculator](#)
 - *Suspected acute rheumatic fever clinical pathway* (Qld) <https://clinicalexcellence.qld.gov.au/sites/default/files/docs/clinical-pathways/suspected-arf-clinical-pathway.pdf>

1. May present with¹

- Symptoms may evolve over several weeks
- Can be very subtle eg joint pain or unexplained fever
- **Sore ± swollen joint** - most common symptom (arthritis or arthralgia):
 - swollen hot joint with pain on movement
 - usually asymmetrical and migratory - 1 joint becoming inflamed as another subsides
 - may involve 1 or multiple joints
 - large joints usually affected - especially knees and ankles
 - usually extremely painful - often out of proportion with clinical signs
 - problems weight-bearing or walking unaided
 - joints may be painful but not swollen
- **Fever ≥ 38** - common
- **Carditis:**
 - heart murmur
 - may be signs of heart failure eg:
 - ↑ RR, ↑ HR (resting)
 - crackles in base of lungs, pulmonary oedema
 - ↑ JVP, oedema in feet/lower legs
 - puffy face, enlarged liver

- **Sydenham chorea** - a mood and movement disorder:
 - jerky, uncoordinated movements eg <https://www.youtube.com/watch?v=VFBOTwmVAoA>
 - especially affects hands, feet, tongue, face
 - disappears during sleep
 - may affect 1 side of the body only
 - very common in Aboriginal and Torres Strait Islander children (28% of presentations)
 - relatives and teachers may describe them as ‘jumpy kids’
 - strongly associated with carditis
 - **note:** Sydenham chorea can develop after other symptoms have resolved and can be used solely to diagnose ARF
- **Rare - subcutaneous nodules:**
 - crops of small round painless nodules over elbows, wrists, knees, ankles, Achilles tendon, occiput and vertebrae
 - highly specific symptom of ARF; strongly associated with carditis
- **Extremely rare - erythema marginatum:**
 - circular patterns of bright pink macules or papules on trunk and proximal extremities
 - difficult to detect in dark skinned people, but highly specific for ARF

2. Immediate management¹

- Look for signs of carditis/heart failure. **If present urgently contact MO/NP:**
 - + strict bed rest

3. Clinical assessment¹

- **Ask about symptoms**, in particular:
 - pain or swelling in limb(s) or joint(s)
 - jerky/uncoordinated movements
 - current or recent fever
 - measures taken to treat symptoms:
 - have they tried ibuprofen for joint pain; how effective
 - history from a relative or teacher eg strange movements
 - recent history of sore throat, painful joint(s) or skin infections, and if treated
- **Get past history**, including:
 - past episodes of ARF or previous symptoms suggesting ARF
 - family history of ARF/RHD
 - history of benzathine benzylpenicillin (Bicillin LA®) injections for ARF/RHD:
 - have any injections been missed
 - if unsure contact RHD Qld ☎ 1300 135 854 or state/territory RHD control program
 - current medicines
- **Do physical examination**, including:
 - vital signs - note any fever
 - ECG - note prolonged P–R interval, a sign of carditis

Upper limits for normal P–R interval ¹	
Age (years)	Seconds
3–11	0.16
12–16	0.18
17+	0.20

- inspect and palpate joints for:
 - swelling, tenderness and mobility
 - does the pain seem out of proportion to the joint signs
- inspect:
 - skin for old or infected sores
 - throat for redness
 - for any jerky movements of the face, tongue, trunk and limbs
- auscultate the heart if skilled - listen for a murmur/abnormal sounds eg whooshing sound
- **Take pathology:**
 - bloods:
 - FBC, ESR, C-reactive protein (CRP)
 - anti-streptococcal serology - both ASO and anti-DNase B titres
 - blood cultures if T \geq 38
 - do throat swab - culture for Group A Strep
 - if skin sores, swab for MCS. See [How to take a wound swab, p. 324](#)
 - **note:** take swab(s) before giving antibiotics

4. Management¹

- Consult MO/NP in all cases
- See:
 - **ARF Diagnosis calculator** <https://www.rhdaustralia.org.au/apps>
 - **Suspected acute rheumatic fever clinical pathway** (Qld):
 - <https://clinicalexcellence.qld.gov.au/sites/default/files/docs/clinical-pathways/suspected-arf-clinical-pathway.pdf> OR
- If monoarthritis (inflammation of 1 joint) consider [Septic arthritis, p. 550](#) until proven otherwise
- Offer analgesia. See [Acute pain, p. 32](#)
 - **give paracetamol.** Withhold NSAIDs (eg ibuprofen) until diagnosis confirmed - can cause joint symptoms to disappear complicating the diagnosis
 - if severe pain consult MO/NP
- MO/NP may:
 - arrange evacuation for physician/cardiology review, echo and for diagnosis
 - hospitalisation should occur within 24–72 hours after onset of symptoms, even if symptoms resolve
 - **note:** thorough investigations for alternative diagnoses should always be undertaken eg septic arthritis, disseminated gonococcal infection, gout, innocent murmur, congenital heart disease
- **If ARF possible/suspected give:**
 - benzathine benzylpenicillin (Bicillin LA®)
 - if allergic give:
 - cefalexin if hypersensitivity to penicillin eg rash OR
 - azithromycin if anaphylaxis or immediate reaction to penicillins
- Contact Public Health Unit, RHD Qld ☎ 1300 135 854, or state/territory RHD control program for advice as needed



S ₄	Benzathine benzylpenicillin (Bicillin LA®)			Extended authority ATSIHP/IHW/IPAP/RIPRN
ATSIHP, IHW, IPAP and RN must consult MO/NP				
RIPRN may proceed				
Form	Strength	Route	Dose	Duration
Prefilled syringe	1.2 million units/2.3 mL	IM	Child < 20 kg 600,000 units (1.2 mL)	stat Inject slowly over at least 2–3 minutes
			Adult or Child ≥ 20 kg 1.2 million units (2.3 mL)	
Offer CMI: May cause diarrhoea, nausea and pain at injection site				
Note: Ventrogluteal , p. 564 or vastus lateralis sites preferred. Do not give in deltoid. See Managing injection pain , p. 563				
Contraindication: Severe or immediate allergic reaction to a penicillin. Be aware of cross-reactivity between penicillins, cephalosporins and carbapenems				
Management of associated emergency: Consult MO/NP. See Anaphylaxis , p. 82 1,2				

S ₄	Cefalexin			Extended authority ATSIHP/IHW/IPAP/RIPRN
ATSIHP, IHW, IPAP and RN must consult MO/NP				
RIPRN may proceed				
Form	Strength	Route	Dose	Duration
Capsule	250 mg, 500 mg	Oral	Adult 1 g bd	10 days
Oral liquid	250 mg/5 mL		Child 25 mg/kg (max. 1 g) bd	
Offer CMI: May cause rash, diarrhoea, nausea, vomiting, dizziness, headache or thrush				
Note: If renal impairment seek MO/NP advice				
Contraindication: Severe or immediate allergic reaction to a cephalosporin or a penicillin. Be aware of cross-reactivity between penicillins, cephalosporins and carbapenems				
Management of associated emergency: Consult MO/NP. See Anaphylaxis , p. 82 1,3,4				

S ₄	Azithromycin			Extended authority ATSIHP/IHW/IPAP/RIPRN
ATSIHP, IHW, IPAP and RN must consult MO/NP				
RIPRN may proceed				
Form	Strength	Route	Dose	Duration
Tablet	500 mg	Oral	Adult 500 mg daily	5 days
Oral liquid	200 mg/5 mL		Child 12 mg/kg (max. 500 mg) daily	
Offer CMI: May cause rash, diarrhoea, nausea, abdominal cramps or thrush				
Management of associated emergency: Consult MO/NP. See Anaphylaxis , p. 82 1,5,6				

5. Follow up¹

- As per guidance of specialist MO

6. Referral/consultation¹

- Consult MO/NP on all occasions of suspected ARF
- Suspected ARF requires immediate notification to the Public Health Unit (Qld, NT, WA, SA + NSW) based on clinical presentation ②

Ear problems

Ear assessment - adult/child

Recommend¹

- **Check ears every time a child attends the clinic**
- Encourage to bring child to clinic if any ear symptoms, concerns about hearing or language
- If hearing loss, the school/day care can put in measures to assist the child eg sound field amplification systems and student placement (seating) in the classroom

Background¹

- Otitis media (OM) is inflammation ± infection in the middle ear. OM in Aboriginal and Torres Strait Islander children can start in the first months of life, and may lead to recurrent ± chronic infections and hearing loss. **Hearing loss can have a lifelong impact** eg speech development, learning
- Resources:
 - *Deadly ears* <https://www.childrens.health.qld.gov.au/chq/our-services/community-health-services/deadly-ears/>
 - *Care for kids* <http://www.careforkidsears.health.gov.au/internet/cfke/publishing.nsf/Content/Home>
 - *Otitis media guidelines* + App <https://otitismediaguidelines.com/#/start-main>
 - *Chronic conditions manual* <https://www.health.qld.gov.au/rccsu/clinical-manuals/chronic-conditions-manual-ccm> - how to do hearing checks, tympanometry and audiometry

Preventing ear infections¹

- Frequent handwashing, especially after blowing nose/coughing
- Keep face and hands clean of nasal discharge
- Pneumococcal and influenza vaccination
- 'Blow, breathe, cough'²
- Breastfeed. If bottle feeding, use upright position (not lying in cot)
- Restrict use of dummies > 6 months of age
- Keep sick children away from babies
- Keep away from smoke

1. May present with¹

- No symptoms - routine check of ears
- Sore, itchy, or discharging ear(s) or hearing loss
- Young child - pulling/rubbing/holding ear(s), unsettled/irritable, ↓ feeding
- Concerns about ears, hearing or language/talking

2. Immediate management¹

- If unwell child with fever, screen for [Sepsis, p. 64](#)

3. Clinical assessment¹

- **If ear symptoms, ask about:**
 - onset, severity, duration
 - pain/itchy
 - discharge - colour, amount
 - deafness, fullness
 - dizziness/tinnitus (ringing in the ear)
 - recent swimming/water sports
 - trauma/blow to ear eg slap, diving, object poked in³



Positioning child to examine ears and throat

- Any other symptoms eg:
 - runny nose, sore throat, cough
 - hearing loss
 - concerns about language/talking, learning or behavioural problems (could mean ↓ hearing)
- Get past history:
 - prior ear infection(s), perforation(s), operation(s) to ear, ENT review - what, when, treatment
 - prior serious illnesses eg meningitis
 - last hearing test/audiology (date), results
 - family history of ear/hearing concerns

Examine ears^{1,4,6}

- Examine both ears. Start with normal ear
- **Check pinna** (outer ear). Any:
 - discharge, flaky or scaly skin
 - pain on moving pinna or tragus (flap of skin in front of ear canal)
 - is ear pushed out/forwards
- **Check behind ear** for redness or swelling
- Palpate for swollen/tender lymph glands - around ears and neck
- **Look inside ear with otoscope** - if pain levels allow:
 - pull pinna to straighten canal: **adult** - up, out and back; **child** - down and back
 - if pus/discharge - gently clean with [Tissue spears, p. 530](#) first
 - if **impacted wax** prevents examination consider syringing with warm water (**if skilled**):⁷
 - **note:** do NOT irrigate if perforation likely, diabetes, immunocompromised or on anticoagulants⁷
- **Ear canal:**
 - swelling, redness, lump(s), flakes/scales
 - discharge, foreign body, debris, dislodged grommet (ventilation tube)
- **Tympanic membrane (TM)** (eardrum):^{1,6}
 - colour - pearly grey, yellow/amber, pink/red, white (pus), white chalky patches (scarring)
 - translucency - shiny/translucent (normal), opaque, dull/cloudy, fluid/bubbles
 - position - neutral, bulging or retracted (sucked in):
 - handle of malleus is prominent if retracted, or not seen well if bulging⁶
 - perforation (hole) - position, duration, size (a readily visible hole is 'moderate' to 'large' size):³
 - a severely retracted eardrum, retraction pocket or healed hole might be mistaken for a perforation⁸
 - grommet

Eardrum red flags⁹ ANY of

- Hole or retraction in attic (upper) area
- Crust/granulation/discharge in attic area
- Severely retracted (sucked in) eardrum
- Dull white mass behind eardrum
- Perforation near edge of eardrum

Could be **Cholesteatoma**
Consult MO/NP for urgent ENT referral

- **Consider looking for movement of intact eardrum(s)** if not too painful:¹
 - if eardrum moves in and out easily you can exclude a perforation + fluid in the middle ear (ie exclude otitis media and acute otitis media)
 - **check for movement by:** gentle valsalva (hold nose and blow), pneumatic otoscopy or tympanometry (Type A is normal)
- **Check nose, throat, chest** + other systems as needed

Normal eardrum (left ear)

- Pearly grey, shiny, translucent, cone of light present, no redness, handle of malleus vertical
- Also see *Educational resources* in the [Otitis media guidelines](#) for photos

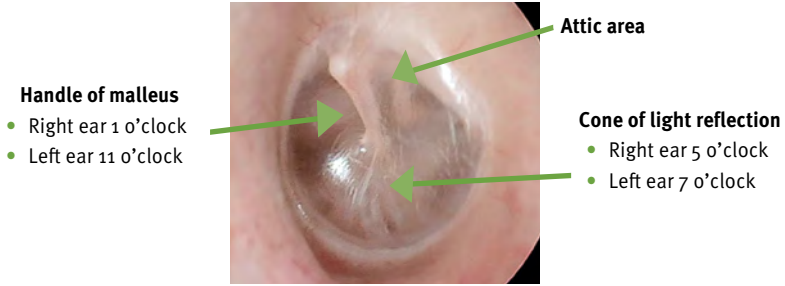

Ear differential diagnosis^{1,4,6}

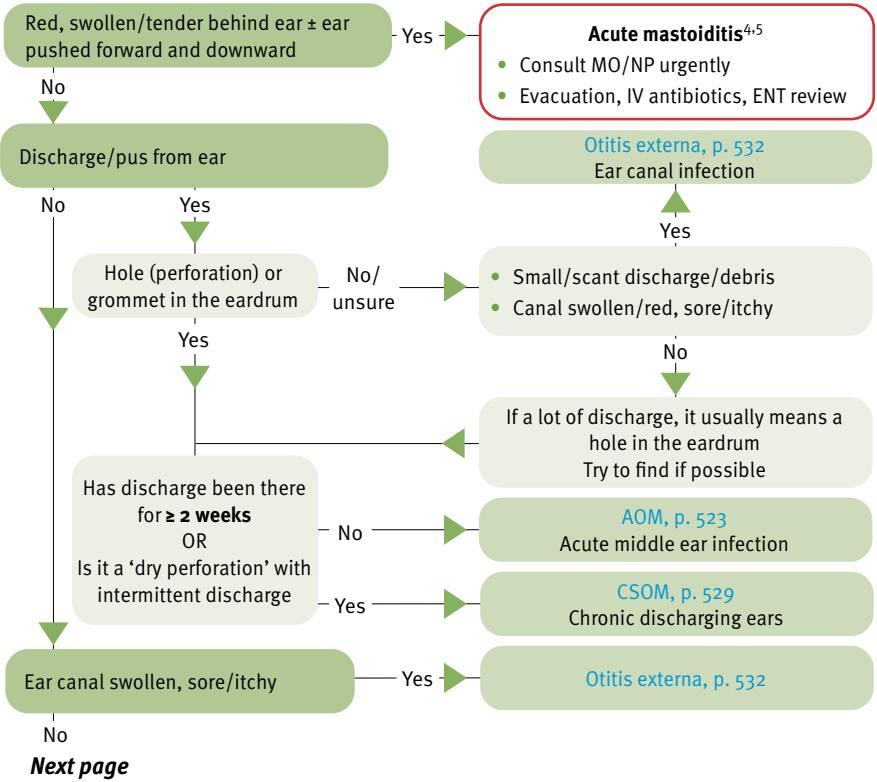

Next page

From previous page

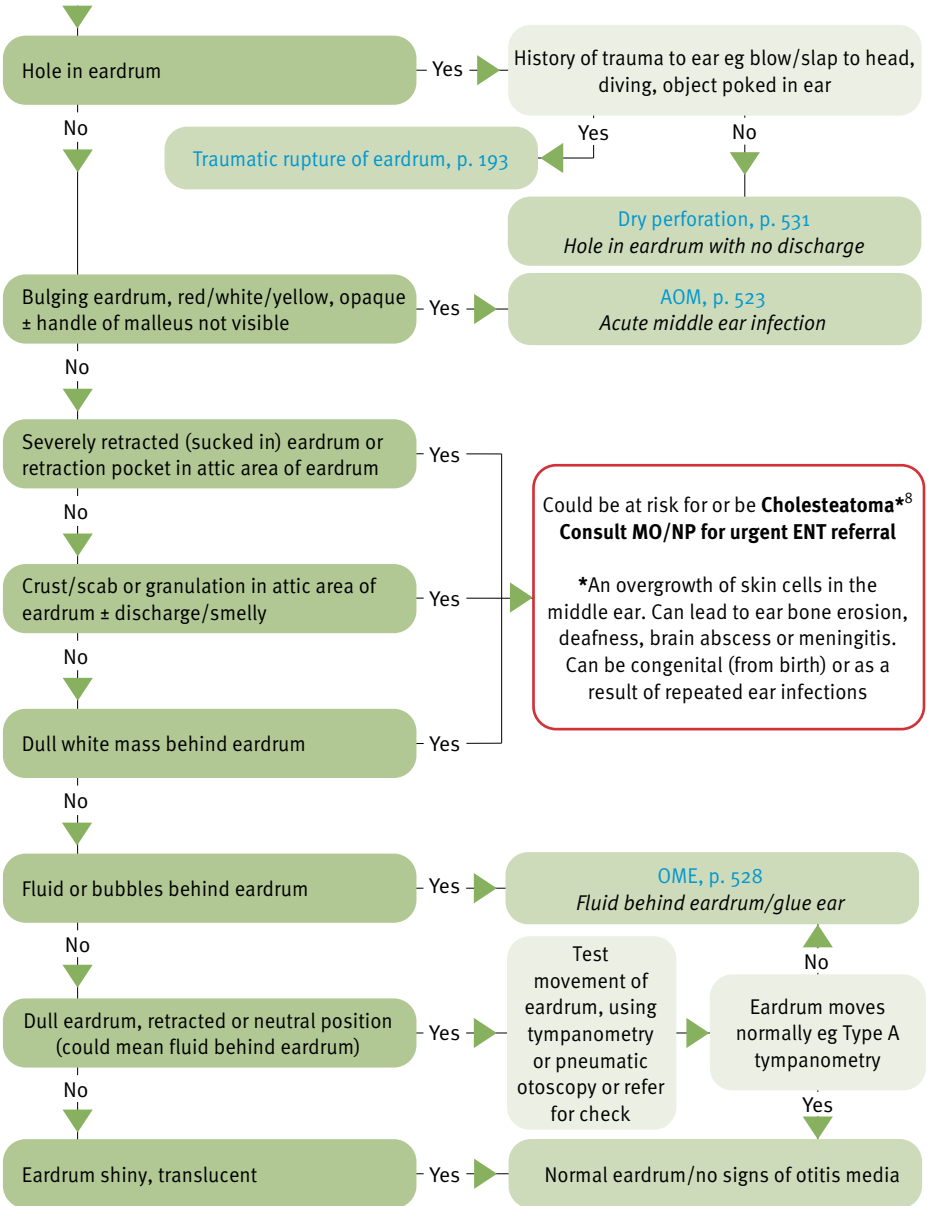

Could be at risk for or be **Cholesteatoma***⁸
Consult MO/NP for urgent ENT referral

*An overgrowth of skin cells in the middle ear. Can lead to ear bone erosion, deafness, brain abscess or meningitis. Can be congenital (from birth) or as a result of repeated ear infections

HMP Acute otitis media (AOM) - adult/child

Acute middle ear infection ± perforation

Recommend^{1,2}

- A red eardrum alone is not diagnostic of AOM. It can also be caused by crying, fever, URTI
- Always consider other causes of illness in a sick child with fever

Background¹

- Perforation of the eardrum is common, resulting in ear discharge and relief of pain²

1. May present with¹⁻³

- Acute onset of:
 - bulging eardrum (can look red or white/yellow)
 - fluid in the middle ear **OR** ear discharge for < 2 weeks
- ± symptoms eg:
 - pain, fever, lethargy
 - URTI symptoms eg cough, runny nose
 - pulling/rubbing/holding ear(s)
 - unsettled/irritable (young child)
 - infant may present with feeding difficulties

2. Immediate management^{1,2}

- Do vital signs
- Screen for [Sepsis, p. 64](#)

3. Clinical assessment¹

- Get history, including:
 - pain - location, onset
 - discharge from ear - duration¹
 - previous ear infections - when, how treated
 - grommets
 - other symptoms - eg fever, cough, runny nose, rash, nausea/vomiting, diarrhoea
 - feeding - normal or ↓ intake
 - times passed urine/number of wet nappies in last 24 hours
 - immunocompromised
- Do physical examination, including:
 - full examination if unwell child
 - ears as per [Ear assessment, p. 519](#)
 - eardrum - look for bulging OR perforation with discharge
 - it may be difficult to see eardrum if profuse discharge, especially in infants⁴
 - nose, throat, chest
- If ear discharge, take swab for MCS

4. Management¹⁻⁴

- Consult MO/NP if any of:
 - < 3 months of age
 - T ≥ 39
 - rash, ↑ RR, or respiratory distress
 - looks sick, lethargic, pale, irritable, not alert or interactive when T reduced
 - immunocompromised
- Assess if antibiotics indicated as per table below^{3,4}

Indications for antibiotics for AOM

Indications for antibiotics - if any of:

- Systemically unwell ie lethargic, pale, very irritable
- Infant < 6 months of age
- Child < 2 years old with AOM in both ears
- Ear discharging/perforation
- Symptoms present for > 48–72 hours
- Child at HIGH RISK of complications/ chronic ear infections⁴**

Child at 'HIGH RISK of complications'

- **Aboriginal and Torres Strait Islander child** if any of:
 - living in remote community
 - < 2 years old
 - first episode of OM < 6 months of age
 - family history of CSOM (runny ears)
 - current or prior perforation
- **Any child** if any of:
 - immunocompromised, cochlear implant
 - craniofacial abnormalities, cleft palate
 - developmental delay, Down syndrome
 - existing hearing loss, severe visual impairment

- **If antibiotics NOT indicated:**⁴
 - reassure AOM will often resolve by itself
 - advise to be reviewed in 2–3 days or sooner if becomes more unwell
 - if after 2–3 days there is no improvement, offer antibiotics
- **If antibiotics ARE indicated** - see **Antibiotics for AOM** flowchart
- **In all cases, advise:**³
 - symptoms usually last 2–3 days. If acute perforation, it will usually heal in around 10 days
 - if ear discharging clean with [Tissue spears, p. 530](#)
 - if pain/discomfort, regular paracetamol ± ibuprofen.^{4,5} See [Acute pain, p. 32](#)
 - if severe pain, unrelieved by above, consult MO/NP

Antibiotics for AOM^{3,4}

- **Note: if allergy to penicillins**, REPLACE amoxicillin with trimethoprim + sulfamethoxazole and consult MO/NP if not responding to treatment

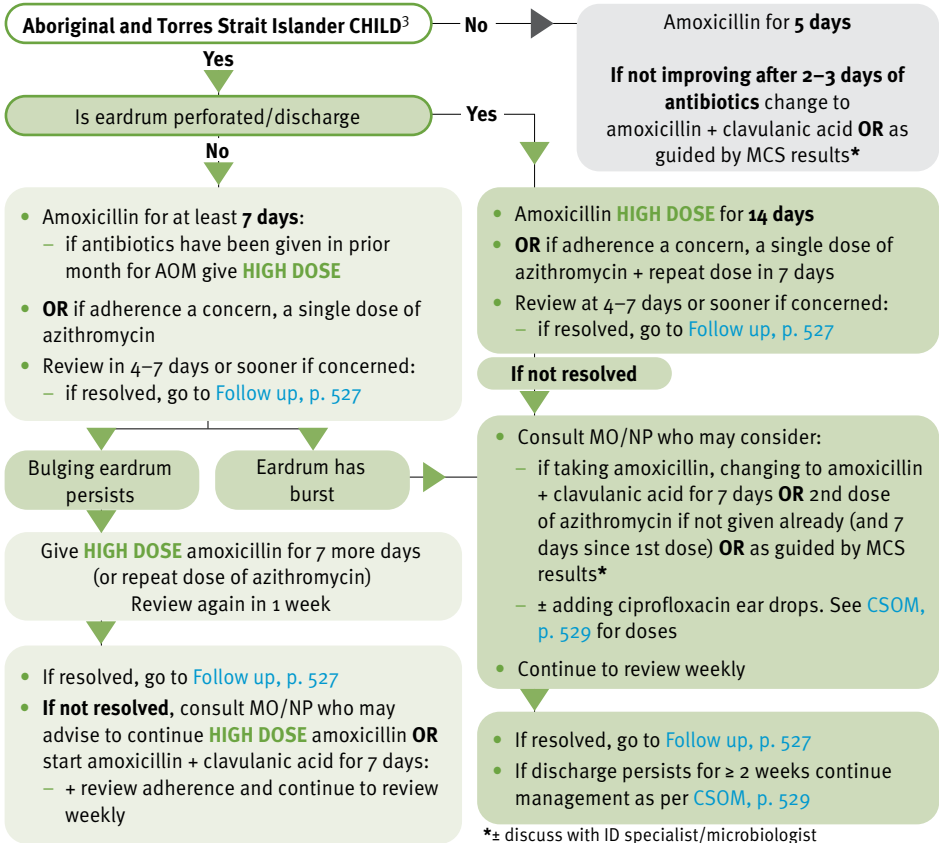

*± discuss with ID specialist/microbiologist

S4	Amoxicillin			Extended authority ATSIHP/IHW/IPAP/RIPRN
ATSIHP, IHW, IPAP and RN must consult MO/NP				
RIPRN may proceed				
Form	Strength	Route	Dose	Duration
Capsule	250 mg 500 mg	Oral	Adult and child ≥ 12 years 1 g bd	5 days
			Child > 1 month to < 12 years 30 mg/kg (max. 1 g) bd	5–7 days
Oral liquid	250 mg/5 mL 500 mg/5 mL		HIGH DOSE Child > 1 month to < 12 years 45 mg/kg (max. 1 g) bd	7 days If perforation 14 days
Offer CMI: May cause rash, diarrhoea, nausea or thrush				
Contraindication: Severe or immediate allergic reaction to a penicillin. Be aware of cross-reactivity between penicillins, cephalosporins and carbapenems				
Management of associated emergency: Consult MO/NP. See Anaphylaxis, p. 82				3,4,6

S4	Azithromycin			Extended authority ATSIHP/IHW/IPAP/RIPRN
ATSIHP, IHW, IPAP and RN must consult MO/NP				
RIPRN may proceed				
Form	Strength	Route	Dose	Duration
Tablet	500 mg	Oral	Child 30 mg/kg (max. 1 g)	Single dose Given as direct observed treatment. Repeat in 7 days if indicated
Oral liquid	200 mg/5 mL			
Offer CMI: May cause rash, diarrhoea, nausea, abdominal cramps or thrush				
Management of associated emergency: Consult MO/NP. See Anaphylaxis, p. 82				3:9

S4	Amoxicillin + clavulanic acid			Extended authority ATSIHP/IHW/IPAP/RIPRN
ATSIHP, IHW, IPAP and RN must consult MO/NP				
RIPRN may proceed				
Form	Strength	Route	Dose	Duration
Tablet	875 mg + 125 mg	Oral	Child > 2 months 22.5 mg/kg (max. 875 mg) bd <i>Dose as per amoxicillin component</i>	5–7 days
Oral liquid	400 mg + 57 mg/5 mL			
Offer CMI: Take with food. May cause rash, diarrhoea, nausea or thrush. Can cause severe diarrhoea (colitis) due to <i>C. difficile</i>				
Contraindication: Severe or immediate allergic reaction to a penicillin. Be aware of cross-reactivity between penicillins, cephalosporins and carbapenems				
Management of associated emergency: Consult MO/NP. See Anaphylaxis, p. 82				3:4,7

S4	Trimethoprim + sulfamethoxazole			Extended authority ATSIHP/IHW/IPAP/RIPRN
ATSIHP, IHW, IPAP and RN must consult MO/NP				
RIPRN may proceed				
Form	Strength	Route	Dose	Duration
Tablet	80 + 400 mg 160 + 800 mg	Oral	Adult 160 + 800 mg bd Child > 2 months–12 years 4 mg/kg (max. 160 mg) bd <i>Dose as per trimethoprim component</i>	5–7 days
Oral liquid	40 + 200 mg/5 mL			
Offer CMI: Take with food to reduce stomach upset. May cause fever, nausea, vomiting, diarrhoea, itch, rash or sore mouth. Avoid sun exposure. Report straight away if sore throat, fever, rash, cough, breathing difficulties, joint pain, dark urine or pale stools				
Note: If renal impairment, taking ACE inhibitor or potassium, HIV or SLE seek MO/NP advice				
Pregnancy: Do not use in the 1st trimester or in late pregnancy				
Contraindication: Severe or immediate allergic reaction to sulfonamides, megaloblastic anaemia, severe hepatic impairment, elderly				
Management of associated emergency: Consult MO/NP. See Anaphylaxis, p. 82				3:4,8

5. Follow up^{1,3}

- Follow up results of MCS. Check if sensitive to current antibiotics (discuss with MO/NP if not)
- Check taking antibiotics correctly at each review. Offer support as needed
- **If unwell** advise daily review until improving, or sooner if concerned (consult MO/NP if concerned):
 - then advise review after 4–7 days + weekly until resolved
- **If acute perforation, advise review again at 6 weeks.** If still perforated, refer to MO/NP clinic
- **If eardrum intact, advise review again at 3 months:**
 - check for persistent fluid behind the eardrum. If present, see [OME, p. 528](#)
 - **note:** it is common for fluid to be present for about a month after AOM but it is mostly gone by 3 months
- **If AOM resolved, but recurrent ie** ≥ 3 episodes in prior 6 months **OR** ≥ 4 episodes in prior year:
 - if ‘child at high risk of complications’ refer to next MO/NP clinic:
 - may need 3–6 months of prophylactic antibiotics
 - review monthly for 3 months:
 - if further episodes of AOM in the 3 month period, arrange ENT referral + hearing assessment
 - if no further AOM advise parent/carer to return if any concerns
- Continue routine screening as per **Ears and hearing checks** in the *Chronic conditions manual* <https://www.health.qld.gov.au/rrcsu/clinical-manuals/chronic-conditions-manual-ccm>

6. Referral/consultation¹

- If there are concerns about child’s hearing, speech development, behaviour or school progress, refer for formal hearing assessment if not done recently

Otitis media with effusion (OME) - child

Fluid behind the intact eardrum(s), glue ear

Background^{1,2}

- If fluid persisting > 3 months in both ears, treatment may be needed to help restore hearing loss

1. May present with^{1,2}

- Fluid behind intact eardrum(s) AND no symptoms:
 - detected by loss of movement of eardrum - shown by Type B tympanometry, pneumatic otoscopy or valsalva eg on routine ear check
- Suspect if:
 - dull eardrum/light reflex missing ± eardrum retracted
 - grey-white fluid or bubbles behind eardrum - can be hard to see
 - ± hearing loss - may be evident through speech delay/learning or behavioural issues

2. Immediate management Not applicable

3. Clinical assessment^{1,2}

- Get history and examine ears as per [Ear assessment, p. 519](#), including:
 - prior OME/ear infections, when, treatment, is child under ENT specialist
 - any concerns about hearing, speech and learning/behavioural problems, development
 - hearing test(s) - when, results
 - do vital signs
 - if possible, do valsalva, tympanometry or pneumatic otoscopy to confirm eardrum not moving. See [Ear assessment, p. 519](#)

4. Management^{1,2}

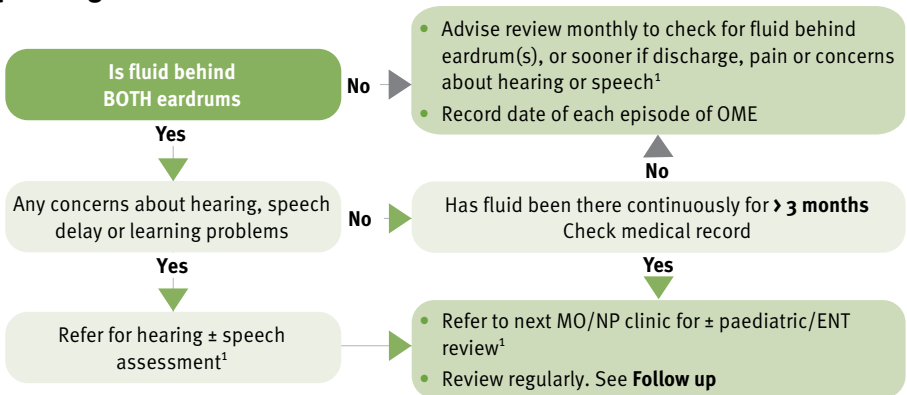

- Consider antibiotics for otitis media ONLY if symptoms of acute infection present³⁻⁵

5. Follow up¹

- Advise to be reviewed in 1 month - add to recall list/clinic reminders
- If bilateral OME resolved, or OME in 1 ear only, continue regular review of ears eg monthly

6. Referral/consultation

- As above¹

HMP Chronic suppurative otitis media (CSOM) - child

Ear(s) discharging for ≥ 2 weeks

Background

- Chronic discharging ear(s) can cause hearing impairment and disability. Occasionally serious complications can occur eg intracranial infection or mastoiditis¹

1. May present with^{1,3}

- Ear discharge present for ≥ 2 weeks + eardrum perforation (hole)

2. Immediate management Not applicable

3. Clinical assessment³

- Get history as per [Ear assessment, p. 519](#), including:
 - amount + duration of ear discharge
 - prior ear infections, when, treatment, is child under ENT specialist, grommet(s)
 - any concerns about hearing, speech and learning/behavioural problems, development
 - hearing test(s) - when, results
- Do vital signs
- Examine ears:
 - take swab for MCS first
 - use [Tissue spears, p. 530](#) to clean
 - document size and location of hole in eardrum eg draw picture in notes
 - if grommet - note position (still in eardrum); any granulation tissue around base
- If pus thick and you are unable to view eardrum, consider initial irrigation of ear. Use diluted Betadine® (1 part Betadine® to 20 parts warm water)³ followed by [Tissue spears, p. 530](#):
 - refer to MO/NP for suctioning under direct supervision if cleaning and irrigating not effective³

4. Management^{1,3}

- Consult MO/NP promptly \pm ENT referral if:
 - $T > 38.5$ or systemically unwell
 - redness/swelling behind the ear³
 - perforation in [Attic area, p. 521](#)
 - crusting or granulation tissue - in attic area or around base of grommet
- If discharge < 2 weeks, treat as [AOM, p. 523](#) with perforation. Unless child has history of dry perforation with intermittent discharge, in which case continue as below

If discharge ≥ 2 weeks³

- Give ciprofloxacin ear drops
- If hole in eardrum is not visible or very small (pin hole size), consult MO/NP who may add amoxicillin or azithromycin as per [AOM, p. 523](#)
- Advise:
 - dry mop with [Tissue spears, p. 530](#) before ear drops + as needed
 - importance of continuing tissue spears + ear drops until ears dry (**may be > 2 weeks/long-term**)
 - water precautions (when swimming/bathing) - use cotton wool in ear with Vaseline® over top, Blu Tack®, or earplugs with swimming cap
 - hearing loss likely while discharging

Tissue spears⁴

- Wash hands before and after doing
- Get tissue. Find the edge of the tissue that will tear straight. Tear strips 1–1.5 cm thick along full length of tissue, then fold strip in half
- Hold edge of ear and pull ‘back’ (young child) or ‘back and up’ (older child) to straighten ear canal
- Insert spear into ear. Twist slowly until it stops going in, or child cries, coughs or blinks
- Leave for about 30 seconds to soak up discharge. Remove and repeat with fresh spears until tip dry

Show parent/carer how to do. Offer fact sheet eg <https://www.childrens.health.qld.gov.au/chq/our-services/community-health-services/deadly-ears/resources/>

S4	Ciprofloxacin			Extended authority ATSIHP/IHW/IPAP/RIPRN
ATSIHP, IHW, IPAP and RN must consult MO/NP				
RIPRN may proceed for Aboriginal and Torres Strait Islander persons only				
Form	Strength	Route	Dose	Duration
Ear drops	0.3%	Ear	Child ≥ 1 month Instil 5 drops in affected ear bd	CSOM Minimum 9 days Continue until ear has been dry for at least 3 days
				AOM with discharge and visible perforation Until ear has been dry for 3 days
Offer CMI: Clean ear(s) with Tissue spears first. The drops will only work if pushed through the hole in the eardrum using ‘tragal pumping’ (press several times on the flap of skin in front of the ear canal). Show parent/carer how to do				
Note: 1 bottle should last for 9–10 days				
Management of associated emergency: Consult MO/NP. See Anaphylaxis, p. 82				1,3,5

5. Follow up

- Advise:^{1,3}
 - see MO/NP at next clinic for ENT referral³
 - **review weekly** until resolved + to get more ear drops
 - at each visit check:
 - any discharge on otoscopy (only profuse discharge is visible outside the ear)
 - using drops correctly
 - adequate **Tissue spearing**
- Consider MO/NP input as needed/not resolving
- **Review 4–6 weeks** after resolved for inspection of TM ± residual perforation

6. Referral/consultation^{1,3}

- Refer for hearing test at time of diagnosis
- If language, learning or behavioural problems, refer to speech pathology

Dry perforation - adult/child

Hole in eardrum with no discharge

1. May present with¹

- Perforated eardrum (hole) without any discharge

2. Immediate management Not applicable

3. Clinical assessment¹

- Get history and examine ears as per [Ear assessment, p. 519](#), including:
 - duration of perforation (if known)
 - recent trauma to ear/head eg slap
 - prior ear infections, when, treatment, is child under ENT specialist
 - concerns about hearing, speech and learning/behavioural problems, development
 - hearing test(s) - when, results
- Examine ears:
 - document size and position of perforation eg draw picture in notes
 - do valsalva, tympanometry or pneumatic otoscopy to confirm eardrum not moving to exclude healed perforation. See [Ear assessment, p. 519](#)
 - note any crusting/scab or granulation on the eardrum/near hole

4. Management¹

- If related to trauma, see [Traumatic rupture of eardrum, p. 193](#)
- **Consult MO/NP for urgent ENT referral if hole** could indicate [Cholesteatoma, p. 522](#) eg:²
 - is in [Attic area, p. 521](#) (upper area) of eardrum OR
 - borders rim of the eardrum OR
 - crusting/scab or granulation on the eardrum/near the hole
- **Otherwise**, advise parent/carer:
 - if a child, is at risk of developing chronic discharging ears
 - will often heal by itself in time, but need to monitor
 - water precautions (when swimming/bathing).¹ Use cotton wool in ear with Vaseline® over top, Blu Tack®, or earplugs with swimming cap

5. Follow up¹

- Advise to return if ear starts discharging
- Otherwise, review monthly until healed

6. Referral/consultation¹

- If perforation persists for > 3 months, refer for hearing test/audiology review + ENT review
- If language, learning or behavioural problems, refer to speech pathology

HMP Otitis externa (acute) - adult/child

Ear canal infection, swimmer's ear, tropical ear

1. May present with¹

- Ear pain (can be severe), itch
- Tenderness on moving outer ear
- ± discharge

2. Immediate management Not applicable

3. Clinical assessment¹

- Get history including:
 - onset, duration
 - swimming/water exposure or trauma to ear canal eg vigorous cleaning/scratching, use of hearing aids
 - prior otitis externa - when, treatment
 - immunocompromised, diabetes, recent radiotherapy
- Do vital signs
- Examine ears - often very painful; approach gently:
 - if discharge, take swab for MCS first
 - dry mop using [Tissue spears, p. 530](#) to clean any discharge/debris from canal. **Do not syringe with water²**
 - using otoscope, look for:
 - widespread redness/swelling of ear canal
 - discharge/debris/foreign body
 - eardrum - intact or perforated - may be too swollen to see. If **no discharge**, consider Tympanometry. Type A means the eardrum is intact¹
- Is cause likely bacterial or fungal³

Bacterial ³	Fungal ³
<ul style="list-style-type: none"> • Very painful on pulling pinna, pressing tragus and on otoscopy 	<ul style="list-style-type: none"> • Itch is predominant over pain, all manipulations are tolerable
<ul style="list-style-type: none"> • Narrow, swollen ear canal 	<ul style="list-style-type: none"> • Usually wide canal
<ul style="list-style-type: none"> • Smelly creamy or dry pus, yellow colour, scaly/flaky canal 	<ul style="list-style-type: none"> • Debris is thick 'wet newspaper' (hyphae) and 'salt and pepper' (spores)

4. Management¹

- Offer analgesia. See [Acute pain, p. 32](#)
- Consult MO/NP if any of:
 - fever
 - cellulitis/redness extends outside the ear canal
 - immunocompromised, diabetes or recent radiotherapy - for oral antibiotics + ear drops
 - perforated eardrum possible or grommet(s) - for alternative ear drops eg ciprofloxacin^{1,2}

Give ear drops²⁻⁵

- If bacterial infection likely give:
 - dexamethasone + framycetin + gramicidin (eg Otodex®, Sofradex®) OR
 - ciprofloxacin ± with hydrocortisone (MO/NP to order)⁹

- If fungal infection likely give:
 - flumetasone + clioquinol (eg Locacorten vioform®) OR
 - triamcinolone + neomycin + nystatin + gramicidin drops (eg Kenacomb Otic®, Otocomb Otic®)
- **If canal occluded due to swelling - use wick:**
 - insert wick into canal eg Merocel Ear Wick®, Pope Oto Wick®, or 1 cm strip of ribbon gauze
 - advise will be uncomfortable to put in, but will ensure drops get deep into the canal
 - once inserted, saturate wick with 5 ear drops (as above)
 - leave wick in place + continue drops at home from next day
- **Advise:**^{1,2}
 - symptoms should improve after 2–3 days of treatment, with full resolution up to 2 weeks⁴
 - keep ear dry + for 2 weeks after resolved. Use cotton wool balls with Vaseline® over top while showering; avoid swimming

Ear drops advice - otitis externa^{4,5}

- Get someone else to put drops in if possible
- Clean ear with [Tissue spears, p. 530](#) first. Clean well, especially if fungal infection, as remaining spores can lead to recurrent infections
- Warm bottle of drops in palm for 5–10 minutes
- Lie with affected ear up. Put in drops and then gently press the tragus for 30 seconds. Stay lying with ear up for at least 3–5 minutes
- Stop using if develop ringing in ears, hearing loss, or difficulty with balance⁴

S4	Dexamethasone + framycetin + gramicidin (Otodex®, Sofradex®)	Extended authority ATSIHP/IHW/IPAP/RIPRN		
ATSIHP, IHW, IPAP and RN must consult MO/NP				
RIPRN may proceed				
Form	Strength	Route	Dose	Duration
Ear drops	Dexamethasone 0.05% framycetin 0.5% gramicidin 0.005%	Ear	3 drops into affected ear tds	5–7 days Use until a few days after symptoms cleared. Do not exceed 2 weeks
Management of associated emergency: Consult MO/NP				2,3,6

S4	Flumetasone + clioquinol (Locacorten vioform®)	Extended authority ATSIHP/IHW/IPAP/RIPRN		
ATSIHP, IHW, IPAP and RN must consult MO/NP				
RIPRN may proceed				
Form	Strength	Route	Dose	Duration
Ear drops	Flumetasone 0.02% clioquinol 1%	Ear	Adult and child > 2 years 3 drops into affected ear bd	5–7 days Use until a few days after symptoms cleared. Do not exceed 2 weeks
Management of associated emergency: Consult MO/NP				2,5,7

S ₄	Triamcinolone + neomycin + nystatin + gramicidin (Kenacomb Otic®, Otocomb Otic®)		Extended authority ATSIHP/IHW/IPAP/RIPRN	
ATSIHP, IHW, IPAP and RN must consult MO/NP				
RIPRN may proceed				
Form	Strength	Route	Dose	Duration
Ear drops	Triamcinolone 0.1% neomycin 0.25% nystatin 100,000 units/mL gramicidin 0.025%	Ear	3 drops into affected ear tds	3–7 days
Management of associated emergency: Consult MO/NP. See Anaphylaxis, p. 82				2,8,9

5. Follow up

- **If wick inserted** advise to be reviewed in 2–3 days:²
 - remove wick. If canal still swollen, insert another wick and continue with drops
 - if canal not swollen (wick may have fallen out by itself), continue drops without wick
 - advise review again in 2 days. If no improvement, consult MO/NP
- **If no wick inserted** advise review in 5 days (or sooner if worried/worsening):
 - if no improvement consult MO/NP, who may change ear drops ± consider other causes
- If prone to otitis externa, advise to try to keep ear canal free of water. Acetic acid + isopropyl alcohol ear drops eg Aquaear® after water exposure may help to dry ears⁴

6. Referral/consultation

- As above

Gastrointestinal problems

HMP Gastroenteritis/dehydration - child Diarrhoea ± vomiting

Recommend¹⁻³

- Rehydration is the most important part of management eg with oral rehydration solution (ORS)

Background¹⁻³

- Most gastroenteritis is viral, self-limiting and resolves without specific treatment
- Antibiotics are of no benefit in most cases and may exacerbate diarrhoea
- Also see *Gastroenteritis - emergency management in children* <https://www.childrens.health.qld.gov.au/qpec-statewide-guidelines/>

Related topics

[Giardiasis, p. 538](#)

1. May present with¹

- Sudden onset of diarrhoea ± vomiting, fever or abdominal pain/distension
- Lethargy or altered level of consciousness
- Irritability
- Dehydration

2. Immediate management

- Do vital signs
- Assess hydration. **Note:** if in doubt, manage as if dehydration falls into the more severe category¹
- **If any signs of shock:**
 - contact MO/NP urgently
 - treat as per [Shock, p. 62](#). Also consider [Sepsis, p. 64](#)

Hydration assessment			
	Mild dehydration	Clinical dehydration 5–10% fluid loss	Shock > 10% fluid loss
Level of consciousness		may have altered responsiveness	↓
Skin colour		unchanged	pale or mottled
Extremities		warm	cold
Eyes	No clinical signs but may be thirsty	sunken	sunken
Mucous membranes		dry	dry
HR		normal	↑
RR		↑	↑
Peripheral pulses		normal	weak
Capillary refill		normal	> 2 seconds
Skin turgor		↓	↓
BP		normal	↓

3. Clinical assessment^{1,4}

Consider differential diagnoses¹

- Look for signs of: UTI, meningitis, pneumonia, otitis media, appendicitis, intussusception, bowel obstruction

ALERT consider [Button battery](#), p. 80 ingestion in all children with vomiting

- Get history, including:
 - gastrointestinal symptoms:
 - date/time of onset, frequency, is there blood ± mucous in stools, bile stained or green vomit, location and severity of abdominal pain
 - times passed urine/number of wet nappies in last 24 hours
 - how many drinks/breastfeeds in last 24 hours
 - other symptoms:
 - fever, rash, headache
 - known illness in contacts
- Do physical examination, including:
 - weight - bare weight if < 2 years
 - urinalysis - ketones, signs of UTI
 - BGL
 - check + palpate:
 - abdomen for distension, guarding, rigidity
- Do stool MCS + PCR if:
 - blood ± mucous in stool
 - immunocompromised
 - recent travel overseas
 - diarrhoea > 7 days
- Look for **Risk factors for dehydration** and **Red flags**

Risk factors for dehydration ¹	Red flags ¹
<ul style="list-style-type: none"> • < 1 year, preterm and < 6 months • Low birth weight, failure to thrive • > 5 diarrhoeal stools in 24 hours • Stopped breastfeeding during illness • Signs of malnutrition • Immunocompromised • Underlying chronic conditions 	<ul style="list-style-type: none"> • Severe or localised abdominal pain • Abdominal distension • Isolated vomiting • Biliious (green) vomiting • Blood in stool or vomit • Child appears very unwell or is very drowsy • T > 39 or 38 if < 3 months⁵ • Headache • Rash • Persistent diarrhoea > 10 days

4. Management^{1,4}

- Contact MO/NP if:
 - < 3 months
 - risk factors for dehydration
 - red flags
- See **Hydration management** flowchart

Hydration management¹

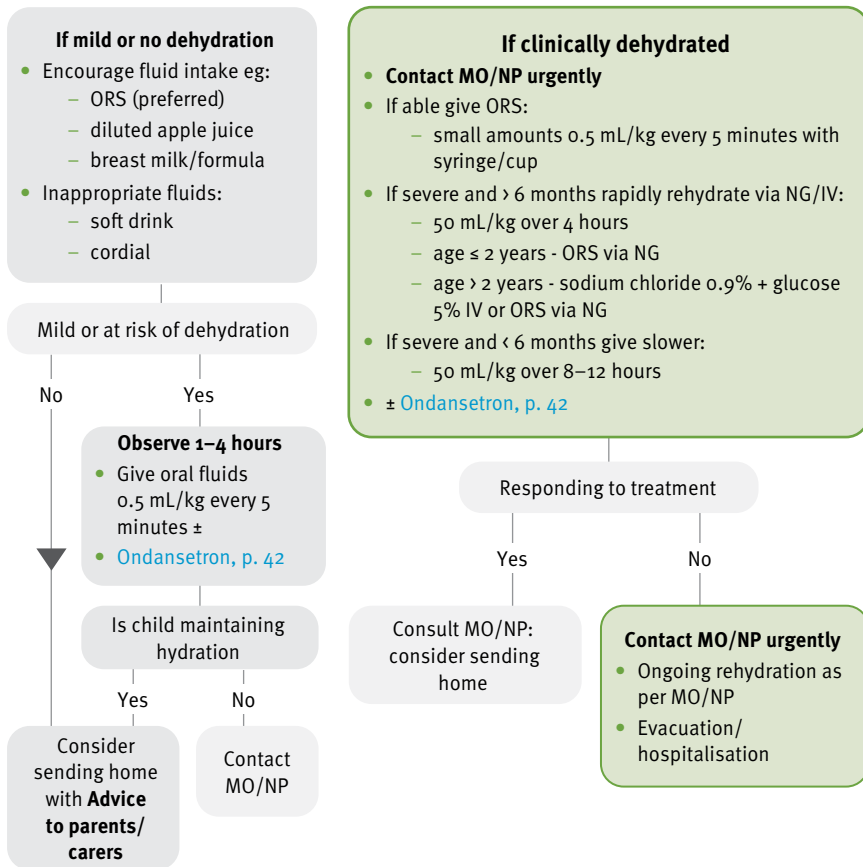

Advice to parents/carers¹

- Wash your hands frequently
- Symptoms usually resolve within 1–2 days, stools can remain loose for 1–2 weeks
- Bring your child back if you are worried or if:
 - develops tummy pain, headache, rash, high fever
 - vomit turns green
 - you notice blood in stool or vomit
- Keep your child drinking fluids, like Gastrolyte®, breast milk or formula, watered down apple juice. Give small sips often using syringe, spoon or cup or icy poles. Avoid sugary drinks like soft drink and cordial
- Offer food if they want it and start gradually with plain pasta, rice or potato, dry toast or plain biscuits. Avoid fatty and sugary foods
- Do not give anti-diarrhoeal medicines to infants or children
- Keep your child away from others until no loose stools in a 24 hour period and they are well⁶

5. Follow up¹

- Advise to be reviewed the following day or earlier if parent/carer is concerned
- Contact MO/NP if symptoms worsen or persist after 2–3 days, or diarrhoea persists > 10 days

6. Referral/consultation

- As above
- Notify Public Health Unit if ≥ 2 cases of diarrhoea ± vomiting in the same location⁶ ⓘ

HMP Giardiasis - adult/child

Background

- Ingestion of Giardia cysts from contaminated water or food is the most common route of transmission, but person-to-person transmission may occur¹

1. May present with^{1,2}

- Diarrhoea, flatulence
- Abdominal cramps, bloating, burping
- Nausea, vomiting
- Fatigue, weight loss
- Positive pathology for Giardia ± symptoms

2. Immediate management Not applicable

3. Clinical assessment^{1,2}

- Ask about:
 - recent travel
 - diarrhoea - watery, mucus or blood, greasy
 - vomiting
 - fever, pain
 - similar illness in contacts
 - immunocompromised
 - water source eg tank water
- Do physical examination, including:
 - vital signs
 - weight - bare weight if < 2 years. Assess against recent weights
 - [Hydration assessment - adult, p. 200](#) or [child, p. 535](#)
 - palpate abdomen for tenderness, guarding
- Do a stool MCS + multiplex PCR if:
 - abdominal symptoms > 2 weeks eg pain, diarrhoea³

4. Management^{3,4}

- Contact MO/NP if:
 - pregnant - treatment may vary³
 - severe symptoms eg mucus or bloody diarrhoea, pain, fever
 - dehydrated. For rehydration see [Gastroenteritis - adult, p. 200](#) or [Gastroenteritis - child, p. 535](#)

- If no symptoms but positive pathology:
 - antibiotics are not required, unless patient handles food³
 - advise patient infection usually self-curing¹
- If symptomatic give metronidazole
- Advise patient:
 - if they prepare or serve food, avoid handling food until they have not had any diarrhoea for 48 hours⁵
 - stay away from others until 24 hours after the last loose bowel motion and they are well⁵
 - wash hands frequently to prevent spreading

S4		Metronidazole		Extended authority ATSIHP/IHW/IPAP/RIPRN	
ATSIHP, IHW, IPAP and RN must consult MO/NP					
RIPRN may proceed					
Form	Strength	Route	Dose	Duration	
Tablet	200 mg 400 mg	Oral	Adult 2 g daily	3 days	
Oral liquid	200 mg/5 mL		Child > 1 month 30 mg/kg (max. 2 g) daily		
Offer CMI: Avoid alcohol while taking and for 24 hours after finishing the course. Take tablet with food to reduce stomach upset. Take oral liquid 1 hour before food for better absorption. May cause nausea, anorexia, abdominal pain, vomiting, diarrhoea, metallic taste, dizziness or headache					
Management of associated emergency: Consult MO/NP. See Anaphylaxis, p. 82 6,7					

5. Follow up³

- Advise to be reviewed if symptoms do not settle or concerned:
 - contact MO/NP who may consider reinfection, drug resistance, alternative diagnosis

6. Referral/consultation

- As above
- Notify Public Health Unit ☎ if:⁵
 - there are more than two cases with diarrhoea ± vomiting in the same location, or
 - a single case in a food handler

HMP Worms - adult/child

Recommend

- Routine deworming is NOT recommended¹

1. May present with

- Poor growth, anaemia
- Abdominal distension, pain, nausea, diarrhoea
- Positive pathology results
- Visible worms in stool eg roundworm, threadworm

Threadworm (pinworm) - most common^{1,2}

- Itchy bottom ± rash from scratching
- Tiny white worms seen around anus or in stool
- Redness and itching around vaginal area in girls
- Irritability

2. Immediate management Not applicable

3. Clinical assessment

- Ask about:
 - immunocompromised³
 - recent travel
 - last treated for worms
- Do:
 - vital signs
 - weight - bare weight if < 2 years. Assess against recent weights
 - offer to look for threadworms around anus
- If not already done:
 - capillary Hb - check normal values in [Anaemia, p. 546](#)
 - stool MCS + multiplex PCR

4. Management^{3,4}

- Contact MO/NP:
 - < 6 months of age
 - tapeworm - may order praziquantel
 - strongyloides - may order ivermectin
- If threadworm:
 - give albendazole OR mebendazole OR pyrantel single dose
 - treat household contacts at same time
 - if still symptoms or visible worms in stools after initial treatment, advise to repeat treatment
- If patient has worms on pathology treat as per drug box
- Reinfection of threadworm and whipworm is common. Advise on hygiene measures eg:³
 - shower/bath daily, frequent hand washing
 - keep finger nails short, avoid scratching bottom
 - wash bedding, towels and clothes in hot water where possible

S4	Albendazole		Extended authority ATSIHP/IHW/IPAP/RIPRN	
ATSIHP, IHW, IPAP and RN must consult MO/NP				
RIPRN may proceed				
Form	Strength	Route	Dose	Duration
Tablet	200 mg 400 mg	Oral	Adult and child > 10 kg 400 mg Child > 6 months and < 10 kg 200 mg	once or If whipworm confirmed on pathology daily for 3 days
Offer CMI: Take on an empty stomach. Tablets may be crushed, chewed or swallowed whole. May cause nausea, vomiting, diarrhoea, headache, dizziness, fever or abdominal pain				
Pregnancy: Avoid during 1st trimester. Use contraception during and for 1 month after treatment. Seek advice for use beyond 1st trimester				
Contraindication: Ocular cysticercosis (tapeworm infection of the eye)				
Management of associated emergency: Consult MO/NP. See Anaphylaxis, p. 82 3:5				

S2	Mebendazole		Extended authority ATSIHP/IHW/IPAP	
ATSIHP, IHW, IPAP and RIPRN may proceed				
RN may administer; for supply see RN supplying, p. 11				
Form	Strength	Route	Dose	Duration
Tablet	100 mg	Oral	Adult and child > 6 months and > 10 kg 100 mg	once or If whipworm, hookworm or roundworm confirmed on pathology bd for 3 days
Oral liquid	100 mg/5 mL		Child > 6 months and < 10 kg 50 mg	
Offer CMI: Tablets may be crushed, chewed or swallowed whole. May cause nausea, vomiting, diarrhoea, headache or abdominal pain				
Pregnancy: Avoid during 1st trimester				
Management of associated emergency: Consult MO/NP. See Anaphylaxis, p. 82 3:6				

S2	Pyrantel		Extended authority ATSIHP/IHW/IPAP	
ATSIHP, IHW, IPAP and RIPRN may proceed				
RN may administer; for supply see RN supplying, p. 11				
Form	Strength	Route	Dose	Duration
Tablet	125 mg 250 mg	Oral	Adult and child > 1 year 10 mg/kg (max. 1 g)	once or If hookworm confirmed on pathology daily for 3 days Note: not suitable for whipworm
Offer CMI: Can cause nausea, vomiting, diarrhoea, abdominal cramps or headache. Tablets may be crushed and mixed with jam				
Management of associated emergency: Consult MO/NP. See Anaphylaxis, p. 82 3:7				

S ₄	Ivermectin			Extended authority ATSIHP/IHW/IPAP
ATSIHP, IHW, IPAP, RIPRN and RN must consult MO/NP				
Form	Strength	Route	Dose	Duration
Tablet	3 mg	Oral	Adult and child > 15 kg 200 microg/kg (rounded up to the nearest 3 mg)	once Repeat after 7–14 days
Offer CMI: Take with fatty food. May cause headache, fatigue, dizziness, abdominal pain, vomiting or diarrhoea. Resistance can occur after repeated use				
Pregnancy: Do not use. Safe in breastfeeding				
Management of associated emergency: Consult MO/NP. See Anaphylaxis, p. 82				3,8

5. Follow up

- If strongyloides treated with ivermectin - repeat stool MCS + PCR, serology and check for eosinophilia to ensure eradication as guided by MO/NP⁸
- If treatment repeated and symptoms continue, or visible worms in stools, contact MO/NP

6. Referral/consultation

- Consult MO/NP as above

Constipation - child

Background¹

- The normal frequency of stools decreases with age from infancy until around 3 years when the average is 1 stool/day
- Also see *Constipation - emergency management in children* <https://www.childrens.health.qld.gov.au/qpec-statewide-guidelines/>

1. May present with¹

- Hard or painful stools eg pellets, large
- Stools that are less regular than usual
- Passing small amounts of liquid stool in underwear
- Avoiding or holding off passing a stool
- Chronic abdominal pain may be only symptom

2. Immediate management Not applicable

3. Clinical assessment¹

- Ask about:
 - what the child does when the family/carer thinks the child needs to poo
 - frequency and consistency of stools
 - disrupted routine eg toilet training, illness, travel, new sibling, starting day care/school

- Do:
 - vital signs
 - weight, bare weight if < 2 years. Assess against recent weights
 - palpate abdomen - check left lower quadrant for palpable masses - can indicate faecal impaction
 - check anus - position, fissures, bleeding, other abnormalities
 - **note:** digital rectal examination is not required

4. Management¹

- If stools are infrequent but remain soft:
 - reassure parents/carer this is not constipation
 - some breastfed babies have bowel motions every 7–14 days. As long the stool is soft this is normal²
- If child has infrequent eg < 3 hard stools per week, for at least 2 weeks:
 - child is likely constipated
 - contact MO/NP who may consider:
 - laxative treatment
 - referral to paediatrician
 - if toilet training, hold off until stools are soft and regular
- If child anxious or fearful of passing stool, consider discussing with parents/carer:
 - positive reinforcement, avoid blaming the child
 - encourage child to sit on toilet after meals, reward even if no stool is passed

5. Follow up¹

- If given laxatives advise to be reviewed:
 - in 3–7 days to check on progress, or
 - sooner if concerned or child is unwell

6. Referral/consultation

- Consider referral to the next child health nurse/MO/NP clinic

Pyloric stenosis - child

Background¹

- Caused by a thickening of the pylorus (gastric outlet at the bottom of the stomach) causing obstruction and forceful vomiting
- Usually presents between 2–6 weeks of age

1. May present with¹

- Vomiting, getting worse, projectile ± blood
- Always hungry
- Poor weight gain or weight loss
- Dehydration

2. Immediate management Not applicable

3. Clinical assessment¹

- Ask about:
 - vomiting - after feeds, any blood, eager to feed after
 - family history of pyloric stenosis
- Do:
 - vital signs
 - bare weight
 - [Hydration assessment - child, p. 535](#)
 - check abdomen for:
 - mass in right upper quadrant
 - wave like contractions (visible peristalsis) after a feed, see <https://www.youtube.com/watch?v=JfGoVrSuV2Y>

4. Management¹

- Consult MO/NP who may advise:
 - IV fluids, bloods
 - evacuation/hospitalisation
 - nil by mouth, consider NG if vomiting continues after stopping feeds
- Monitor closely until evacuated

5. Follow up

- As per MO/NP instructions

6. Referral/consultation

- Consult MO/NP if suspected pyloric stenosis

Intussusception - child

Background

- A condition where one part of the bowel telescopes into the next part and may cause a blockage¹
- Commonly occurs 2 months–2 years, but can occur at any age²

1. May present with²

- Intermittent pain or distress
- Lethargy
- Diarrhoea and vomiting
- Blood seen in stool

2. Immediate management²

- If signs of shock ↑HR, ↑RR, ↓BP, ↓LOC. See [Shock, p. 62](#)

3. Clinical assessment²

- Ask about:
 - pain - does it come and go
 - vomiting - any bile
 - stools - any bleeding, red currant jelly stools
 - pallor, lethargy - can be episodic and may look well between episodes
 - recent rotavirus vaccination
- Do:
 - vital signs
 - weight - bare weight if < 2 years
 - check abdomen for:
 - sausage shaped mass on right side
 - distension, tenderness, guarding
 - check stool/nappy for blood

4. Management²

- Consult MO/NP who may advise:
 - analgesia
 - evacuation/hospitalisation
 - nil by mouth, consider NGT if transferring by air
- Monitor closely until evacuated

5. Follow up

- As per MO/NP instructions

6. Referral/consultation

- Consult MO/NP if suspected intussusception

HMP Anaemia - child

Recommend

- IM injection of iron is NOT usually recommended - absorption is poor, skin may become discoloured + injection is very painful¹

Background

- Prevent iron deficiency by starting iron-rich foods around 6 months of age²
- Mild iron deficiency in children impacts brain development²
- Some babies eg premature babies, may be on iron as treatment/prevention on discharge from hospital special care nursery which should be continued
- Infants born at term and normal birth weight usually have sufficient iron stores for 4–6 months³
- Aboriginal and Torres Strait Islander children are recommended to have routine Hb checks between 6–9 months, 18 months + girls 10–14 years. See the *Chronic conditions manual* <https://www.health.qld.gov.au/rrcsu/clinical-manuals/chronic-conditions-manual-cm>

1. May present with⁴

- Low Hb detected on routine health check:
 - 6 months–4 years \leq 109 g/L
 - 5–11 years \leq 114 g/L
 - 12–14 years \leq 119 g/L
- \pm symptoms - tiredness, lethargy, irritability, pallor, pale conjunctivae, pica (eating non-foods eg dirt)
- Poor growth, recurrent infections, worm infection

2. Immediate management Not applicable

3. Clinical assessment⁴

- Ask about:
 - anaemia in pregnancy, maternal diabetes
 - IUGR, low birth weight, prematurity
 - gastrointestinal disorders or surgery
 - diet - vegetarian or vegan
 - in babies:
 - were iron rich solids introduced at 6 months or later
 - breastfeeding, formula, cows milk, was cows milk introduced $<$ 12 months
- Do:
 - vital signs + capillary Hb - if not already done
 - weight + height:
 - if $<$ 2 years - bare weight, length + head circumference
 - assess against recent measurements
 - check for heart murmur if skilled

4. Management⁵

- Contact MO/NP if $<$ 6 months

Severe anaemia - Hb \leq 80 g/L

- Consult MO/NP promptly, who will advise ongoing treatment eg evacuation for iron infusion

Mild–moderate anaemia⁵

- Hb:
 - 6 months–4 years \leq 109 g/L
 - 5–11 years \leq 114 g/L
 - 12–14 years \leq 119 g/L
- Give iron supplements eg Ferro-Liquid® or Ferro-Grad® and treat for [Worms, p. 540](#)
- Recheck Hb in 1 month:
 - Hb should start to respond to treatment within a week, expect Hb to rise 20 g/L every 3–4 weeks⁶
 - if not improving refer to MO/NP - need to exclude other conditions
- Discuss diet and nutrition if contributing factor.⁶ See the *Chronic conditions manual* <https://www.health.qld.gov.au/rccsu/clinical-manuals/chronic-conditions-manual-ccm>
 - **note:** dietary changes alone will not improve Hb

S2	Ferrous sulfate (Ferro-Liquid®, Ferro-Grad®)			Extended authority ATSIHP/IHW		
ATSIHP and IHW must consult MO/NP						
RIPRN may proceed. RN may administer; for supply see RN supplying, p. 11						
Form	Strength	Route	Dose		Duration	
Oral liquid	Ferrous sulfate 30 mg/mL	Oral	Daily OR twice weekly supervised		For at least 3 months then review by MO/NP	
			Weight	Mild–moderate		Severe
Tablet	Ferrous sulfate 325 mg		< 10 kg	0.5 mL/kg		1 mL/kg
			10–19 kg	5 mL		10 mL
			20–29 kg	10 mL		20 mL
			30–39 kg	15 mL OR 1 tablet		30 mL OR 1 tablet
		> 40 kg	20 mL OR 1 tablet	40 mL OR 1 tablet		
Offer CMI: Overdose of iron can be fatal. Keep out of reach of children. Take on empty stomach, better absorbed with orange juice. If causes upset stomach, take with food. May cause dark, tarry stools, diarrhoea or constipation. Tablets should be swallowed whole. Dilute Ferro-Liquid® with water, drink through a straw + follow each dose with plain water to prevent discolouration of teeth						
Management of associated emergency: Consult MO/NP. See Anaphylaxis, p. 82				3.7		

5. Follow up

- If severe, follow up as guided by MO/NP
- For other cases advise to be reviewed monthly to check Hb + adherence to iron supplements:
 - continue supplements for 3 months after Hb returned to normal to replenish stores¹
- If not improved after 3 months, refer to MO/NP - should have FBC + iron studies to confirm diagnosis
- Provide support to families as needed. If unable to adhere to daily doses of iron:
 - give twice weekly oral iron under supervision

6. Referral/consultation

- As above + consider referral to dietitian, child health nurse, health worker

Urinary tract problems

HMP Urinary tract infection (UTI) - child

Background

- Diagnosing a UTI in young children can be challenging as symptoms are non-specific¹
- Also see *Urinary tract infection - emergency management in children* <https://www.childrens.health.qld.gov.au/chq/health-professionals/qld-paediatric-emergency-care/>

1. May present with¹

- Fever
- Unwell - looks sick, irritable
- Poor feeding, nausea, vomiting
- Poor weight gain
- Urinary symptoms - frequency, dysuria, haematuria, smelly urine
- Abdominal or loin pain
- Changes to continence in older child

2. Immediate management

- Do vital signs - note BP¹
- Screen for [Sepsis, p. 64](#)

3. Clinical assessment¹

- **Ask about:**
 - fever
 - pain - loin, suprapubic
 - previous UTI - when, treatment
 - difficulties passing urine where age appropriate eg dribbling, straining
 - underlying conditions eg urinary tract malformations
 - consider STI history where appropriate¹
- **Do:**
 - weight - bare weight if < 2 years. Assess against recent weights
 - [Hydration assessment - child, p. 535](#)
 - palpate abdomen, check for:
 - palpable bladder
 - loin or suprapubic tenderness
- Get clean catch urine specimen/MSU:
 - clean genital area with saline soaked gauze, ask child to void
 - if child/baby unable to void on request, use **Quick-Wee** method to encourage
 - **note:** bag specimens are not recommended + cannot be used for UTI diagnosis¹
- Do urinalysis. If results:
 - leucocytes AND nitrites - likely UTI
 - leucocytes OR nitrites - possible UTI
 - **note:** blood or protein is not a reliable marker of UTI¹ - may indicate other causes eg [APSGN, p. 511](#)

- Send clean catch urine/MSU for MCS if:
 - leucocytes OR nitrites present
 - < 3 months of age
- If considering gonorrhoea + chlamydia PCR urine testing in older symptomatic children:¹
 - discuss with MO/NP
 - see [Child protection, p. 551](#)

Quick-Wee^{1,3}

- Give the child/baby a breastfeed, formula, drink
- **Clean** genital area with saline soaked gauze
- Gently **rub** lower abdomen for a few minutes in a circular motion with a gauze soaked in cold water
- **Catch** urine in sterile container



Clean



Rub



Catch

4. Management¹

- Consult MO/NP if:
 - child ≤ 3 months of age
 - possible UTI from dipstick
 - unable to get urine sample
- Further management in collaboration with MO/NP
- Offer analgesia. See [Acute pain, p. 32](#)

5. Follow up¹

- Advise to be reviewed in 1–2 days
- Check urine MCS + contact MO/NP if treatment needs modifying

6. Referral/consultation

- As above

Bone and joint problems

HMP Acutely swollen/painful joint - child

Recommend^{1,2}

- The causes can be difficult to diagnose. Be suspicious of septic arthritis (orthopaedic emergency), acute osteomyelitis and [ARF, p. 515](#)

Background

- Also see *Limp - emergency management in children* <https://www.childrens.health.qld.gov.au/qpec-statewide-guidelines/>

1. May present with^{1,4-6}

- Hot, swollen, tender joint(s) ± fever, malaise and fatigue
- Painful hip
- Joint pain on movement
- ↓ mobility, limp, problems with weight bearing

2. Immediate management²

- Vital signs
- Screen for [Sepsis, p. 64](#)

3. Clinical assessment²⁻⁶

- Assess for **Red flags** - may require urgent further assessment ± evacuation

Red flags¹

- Systemic symptoms eg T ≥ 38.5, malaise, weight loss, night sweats
- < 4 years of age
- Inability to weight bear or severe, localised joint pain
- Inflammation of 1 joint²
- Bony pain
- Possible unwitnessed trauma/non-accidental injury
- Overweight adolescent
- Get history, including:
 - pain - acute or gradual onset
 - ARF/RHD diagnosis or family history of²
 - recent injury/wound - can be minor^{1,3}
 - recent joint surgery
 - other symptoms eg skin infections, sore throat, diarrhoea, fatigue, rash³
 - IV drug use⁶
- Urinalysis
- Examine joints:
 - swelling, tenderness, warmth and mobility
 - in younger children watch how they move, weight bear, crawl, walk¹
 - bony point tenderness - may indicate acute osteomyelitis¹

- Consider [ARF, p. 515](#) - especially if pain seems out of proportion to the joint signs
- Check:¹
 - for swollen lymph nodes
 - skin for bruising, recent sores
 - throat for redness

4. Management²⁻⁷

- **Always consider** septic arthritis, acute osteomyelitis and [ARF, p. 515](#) as cause
- If any red flags contact MO/NP urgently
- **Always contact MO/NP for all acute swollen/painful joint presentations**, who may advise:
 - blood cultures, IV antibiotics
 - x-ray
 - evacuation/hospitalisation ± referral to orthopaedic specialist/paediatrician
- Offer analgesia. See [Acute pain, p. 32](#)

5. Follow up

- In consultation with MO/NP

6. Referral/consultation

- As above

Child protection

Child protection

Recommend

- If outside of Qld, refer to local policy and procedures

Background

- Also see *Child protection factsheets* (Qld Health intranet only) <https://qheps.health.qld.gov.au/csu/factsheets>

1. May present with¹

- Direct or indirect discloses of abuse
- Injuries eg facial, neck bruising, fractures especially < 3 years of age
- Signs of neglect eg untreated physical problems, developmental delay
- Parental risk factors eg domestic and family violence, substance misuse, mental health concerns

2. Immediate management

- Assess and treat any injuries
- Contact MO/NP if:
 - traumatic injuries eg head, chest, abdominal
 - ongoing management as per MO/NP
- If suspected sexual assault, also see [Sexual assault, p. 243](#)

3. Clinical assessment¹

- **Ask about:**
 - who is the carer/guardian
 - if injured:
 - what happened, where, when, who was there
 - does injury(s) fit with the explanation
 - previous injuries
 - medical problems eg non organic failure to thrive
 - is there a delay in seeking medical attention
 - social situation eg domestic and family violence
 - engagement of typical activities eg school attendance
- **Do a comprehensive/detailed - assessment and documentation of any injuries, bruising, scarring however minor:**
 - check the whole body and use diagrams if required +
 - vital signs
- **Observe parent-child interactions, any:**
 - cowering, hyper-vigilance, elevated startle responses
- **Consider non-accidental injury if:**
 - patterned skin injury, bruise, abrasion, burn you recognise eg hand, belt/buckle, cigarette
 - bruising to face, head, ears, bottom, arms
 - < 12 months of age with any bruising or skin injury
 - < 3 years of age with fracture(s)

4. Management¹

- If non-accidental injury is suspected, contact MO/NP:
 - head injuries + fractures may not be obvious clinically + require further investigation eg CT scan/skeletal survey
- If you have formed a reasonable suspicion that:
 - a child has suffered, is suffering or likely to suffer significant harm **AND**
 - may not have a parent able and willing to protect them
 - immediately complete and submit a **Report of suspected child in need of protection** form, see <https://secure.communities.qld.gov.au/CBIR/ChildSafety#> **AND**
 - ring Child Safety Regional Intake Service or Child Safety After Hours Service Centre:
 - ☎ 1300 681 513 or 1800 811 810
 - document the date, time + name of the person you spoke to in the patient's medical record
 - forward a copy of the form to the Child Protection Liaison Officer (CPL0)
 - notify local clinic management as required
- If uncertain about reporting or referring, the *Child protection guide* will help you decide, see <https://secure.communities.qld.gov.au/cpguide/engine.aspx>
- Also see the *Chronic conditions manual*, includes contact details <https://www.health.qld.gov.au/rccsu/clinical-manuals/chronic-conditions-manual-ccm>

5. Follow up

- As needed based on individual circumstances

6. Referral/consultation

- MO/NP as above
- Child Protection Advisor or CPL0 where available/as needed

Immunisations

Immunisations

HMP Immunisations - adult/child

Recommend¹

- Utilise all clinical encounters to assess vaccination status and, when indicated, offer vaccines
- For further advice on immunisations contact your Public Health Unit
- Utilise the *Australian Immunisation Handbook (AIH)* immunisationhandbook.health.gov.au
- Some vaccines may be recommended but not funded. Refer to the National Immunisation Program (NIP) schedule and your state or territory immunisation schedule for funded vaccines

Related topics

[Anaphylaxis, p. 82](#)

[Tetanus immunisation, p. 557](#)

1. May present with¹

- Requesting immunisation(s)
- Opportunistic immunisation eg:
 - during any clinical encounter
 - as part of child health check/chronic disease check
 - hospitalised patient
 - during antenatal visit. See [Antenatal care, p. 364](#)
 - during sexual health assessment
- Immunisation programs eg influenza, COVID-19, school
- Outbreak control response

2. Immediate management Not applicable

3. Clinical assessment¹

- Ensure vaccination procedures are followed as per the ***Australian Immunisation Handbook (AIH)***

Preparing for vaccination

- Obtain documented evidence of vaccines already given. Check as appropriate:
 - Australian Immunisation Register (AIR)
 - *My Health Record*
 - medical records
 - other clinics/GP practice where may have been vaccinated
 - Personal Health Record
 - other organisation or state government immunisation data base
- Assess which vaccines are due
- Consider:
 - occupational and lifestyle factors
 - special risk groups; behavioural risk factors
 - medically at risk
 - Aboriginal and Torres Strait Islander status
- Refer to the ‘catch-up chapter’ in the AIH as needed

Tables from AIH available at

<https://immunisationhandbook.health.gov.au/resources/handbook-tables>

- **Do pre-vaccination screen** using the AIH '**Table. Pre-vaccination screening checklist**'
 - if needed, seek advice from a specialist immunisation clinic, an MO/NP with expertise in vaccination or Public Health Unit
- **Obtain valid consent:**
 - sufficient information about the risks and benefits of the vaccines to be provided
 - see AIH '**Table. Comparison of the effects of diseases and side effects of vaccines on the NIPs**'
 - document consent
 - **note:** explicit verbal consent is required prior to subsequent vaccinations even when written consent has been recorded at previous vaccination encounters
- **Check:**
 - anaphylaxis response kit available and checked - protocols, equipment and medicines to manage anaphylaxis
 - cold chain for storage of vaccines has been maintained and monitored appropriately²
 - see **National Vaccine Storage Guidelines 'Strive for 5'** <https://www.health.gov.au/resources/publications/national-vaccine-storage-guidelines-strive-for-5>

4. Management¹

Giving the vaccine

- The dose, route and technique of administration of the vaccine(s) must be in accordance with the AIH

After vaccination

- Observe patient for 15 minutes
- Advise (preferably in writing):
 - date of next vaccination
 - management of any expected adverse events following immunisation
 - see AIH '**Table. Common side effects following immunisation for vaccines used in the NIPs**'
 - how to report a serious or unexpected adverse event following immunisation
- Check the vaccination status of other family members + offer vaccinations as appropriate
- Document vaccination details in:
 - Personal Health Record (hard copy or eHealth) to be retained by patient
 - medical record
 - AIR
 - clinic recall database if appropriate

Vaccines with special conditions

- **Q Fever:**
 - only to be administered under vaccination programs approved by the Chief Health Officer
 - clinicians must be experienced in skin testing and interpretation as per the AIH
- **Tuberculosis (BCG):**
 - only to be administered by specially trained clinicians who are authorised by a Queensland Tuberculosis Control Unit, and in accordance with the AIH

S ₄	Vaccines	Extended authority
ATSIHP, IHW and RN must consult MO/NP		
IPN and RIPRN may proceed		
SRH may proceed with * only		
MID may proceed with # only. MID may proceed with Ω if completed an immunisation training course		
Antigens - may be used singularly or in combination form as available		
Diphtheria		Meningococcal C
Tetanus		Meningococcal ACWY
Pertussis		Pneumococcal
<i>Haemophilus influenzae</i> type B (Hib)		Rotavirus
Hepatitis A *		Varicella
Hepatitis B #*		Varicella zoster
Human papillomavirus *		Japanese encephalitis
Poliomyelitis		Hepatitis B Immunoglobulin # Midwives only For babies of HBsAG positive mothers
Influenza #Ω		Diphtheria-tetanus-acellular pertussis (dTpa) #Ω
Measles, mumps, rubella #*		COVID-19 #*Ω
Meningococcal B		
Note: Dose, route and timing interval of administration to be in accordance with the AIH. For COVID-19 the clinician must have also completed an approved COVID-19 vaccination training course		
Management of associated emergency: See Anaphylaxis, p. 82		

1

5. Follow up¹

- All serious or unexpected adverse events following immunisation (AEFI) must be promptly reported
 - In Qld complete an AEFI form <https://www.health.qld.gov.au/clinical-practice/guidelines-procedures/diseases-infection/immunisation/service-providers/adverse-event>. If outside of Qld refer to local reporting systems

6. Referral/consultation

- As needed, consult with a specialist immunisation clinic, an MO/NP/IPN with expertise in vaccination, Public Health Unit, or the immunisation section within your state or territory health authority. See the AIH for contact details

HMP Tetanus immunisation - adult/child

1. May present with

- Suspected tetanus prone wound

2. Immediate management Not applicable

3. Clinical assessment¹

Identify if the wound is tetanus prone

- Any wound other than a clean, minor cut is tetanus prone:
 - tetanus may occur after a seemingly trivial injury, such as from a rose thorn
 - it is also possible to have no obvious signs of injury
- In particular:
 - compound fracture
 - bite
 - deep penetrating wound
 - wound containing foreign body, especially wood splinters
 - wound complicated by pyogenic (pus) infection
 - wound with extensive tissue damage eg contusions or burns
 - any superficial wound obviously contaminated with soil, dust or horse manure, especially if topical disinfection is delayed more than 4 hours
 - re-implantation of an avulsed (knocked out) tooth
 - depot injections (subcut or intradermal) in people who inject drugs

Tetanus prone

Not tetanus prone - no further treatment

Check if a tetanus booster ± tetanus immunoglobulin (TIG) is recommended

Type of wound	Prior tetanus vaccines	Time since last dose	Tetanus vaccine recommended	TIG recommended
Clean, minor wound	≥ 3 doses	≤ 10 years	no	no
		> 10 years	yes	
	< 3 doses or uncertain	yes		
All other wounds	≥ 3 doses	< 5 years	no	no*
		≥ 5 years	yes	no*
	< 3 doses or uncertain	yes	yes	

*unless person has immunodeficiency. See AIH immunisationhandbook.health.gov.au

4. Management¹

- All tetanus prone wounds must be disinfected and, where appropriate, have surgical treatment:
 - do this even if the person has up-to-date tetanus vaccinations
- If a tetanus booster ± TIG is recommended:
 - ensure standard vaccination procedures are adhered to as per the AIH
 - See [Immunisations, p. 554](#) for **Preparing for vaccination, Giving the vaccine, After vaccination**

S4	Tetanus vaccines		Extended authority ATSIHP/IHW/IPAP/IPN/RIPRN
ATSIHP, IHW, IPAP and RN must consult MO/NP			
IPN and RIPRN may proceed			
Vaccine	Route	Age	Duration
Diphtheria, tetanus acellular pertussis (DTPa) or a DTPa combination vaccine	IM	Paediatric formulation if < 10 years	stat
Diphtheria, tetanus acellular pertussis (dTpa)		Adolescent/adult formulation if ≥ 10 years†	
Diphtheria, tetanus dT (ADT)		Adult formulation	
Note: Dose, route and timing interval of administration to be in accordance with the AIH.			
†dTpa provides added protection against pertussis and should be considered for adults - not funded			
Management of associated emergency: See Anaphylaxis, p. 82 1			

S4	Tetanus immunoglobulin (TIG)		Extended authority ATSIHP/IHW/IPAP/IPN/RIPRN	
ATSIHP, IHW, IPAP and RN must consult MO/NP				
IPN and RIPRN may proceed				
Form	Strength	Route	Dose	Duration
Injection	250 units	IM	250 units if ≤ 24 hours since injury OR 500 units if > 24 hours since injury	stat
Note: TIG is supplied from the Australian Red Cross Service. Dose, route and timing interval of administration of TIG to be in accordance with the AIH				
Management of associated emergency: See Anaphylaxis, p. 82 1				

5. Follow up

- If primary tetanus course not completed, catch-up schedule may be required. Arrange next visit(s) to complete course
- All serious or unexpected adverse events following immunisation (AEFI) must be promptly reported ①. In Qld complete an AEFI form <https://www.health.qld.gov.au/clinical-practice/guidelines-procedures/diseases-infection/immunisation/service-providers/adverse-event>. If outside of Qld refer to local reporting systems

6. Referral/consultation

- As needed, consult with a specialist immunisation clinic, an MO/NP/IPN with expertise in vaccination, Public Health Unit, or the immunisation section within your state or territory health authority. See the AIH for contact details

Appendices

Best possible medication history (BPMH)¹⁻⁴

- Get an accurate and complete list (or as close as possible) of medicines the patient is currently taking at presentation or as early as possible in care
- Online course **Get it right! Taking a best possible medication history** <https://learn.nps.org.au/>

Step 1

Review sources of available medicines information eg:

- Medication containers, blister packs
- Community pharmacist list, GP referral letters
- Medical record(s), *My Health Record* <https://www.myhealthrecord.gov.au/>

Step 2

Interview the patient ± carer/family if possible

- Names of all medicines patient is taking
- Prescription, over-the-counter, complementary - dose, strength, form, concentration, frequency, duration and why taking:
 - use **Medication history checklist** (below) to guide interview
- Any difficulty taking medicines, how often missed
- Recent change to medicine(s) or doses
- Allergies/bad reaction to any medicines in past, what/when/has it happened since

Step 3

Verify the history with one or more sources of information

- Check that these match up/any inconsistencies
- Where there are discrepancies, ask patient ± advise the MO/NP
- Check a medication reference if unsure about a medicine

Step 4

Record the information on the medical record

- On the designated form or in the electronic medical record
- Document allergies + any recent change(s) to medicines and why
- Give list of medicines when care transferred eg retrieval team, to patient/carer when discharged, at clinical handover

Medication history checklist⁴

<input type="checkbox"/> Prescription medicines	<input type="checkbox"/> Topical medicines eg creams, ointments, lotions, patches
<input type="checkbox"/> Sleeping tablets	<input type="checkbox"/> Complementary medicines eg vitamins, herbal or natural therapies
<input type="checkbox"/> Inhalers, puffers, sprays, sublingual tablets	<input type="checkbox"/> Inserted medicines eg nose, ear, eyes, pessaries, suppositories
<input type="checkbox"/> Oral contraceptives, hormone replacement therapy	<input type="checkbox"/> Injected medicines
<input type="checkbox"/> Over-the-counter medicines	<input type="checkbox"/> Recently completed courses of medicines
<input type="checkbox"/> Anticoagulants/antiplatelets	<input type="checkbox"/> Other people's medicines
<input type="checkbox"/> Analgesics	<input type="checkbox"/> Social and recreational drugs
<input type="checkbox"/> Gastrointestinal medicines (for reflux, heartburn, constipation, diarrhoea)	<input type="checkbox"/> Intermittent medicines eg weekly or twice weekly
	<input type="checkbox"/> Refrigerated medicines

High risk medicines - Anti-infectives, Potassium and other electrolytes, Insulin, Narcotics and other sedatives, Chemotherapeutic agents, Heparin, enoxaparin, warfarin and other anticoagulants

Patient death in absence of medical officer

Recommend

- Follow HHS/local policy + procedures. If outside of Qld refer to local policy + procedures
- Death in community can be very emotional + distressing. Be guided by local health workers + clinic management
- If neonatal death or stillbirth - MO will advise. Also see Qld Clinical Guideline *Stillbirth care* <https://www.health.qld.gov.au/qcg/publications#maternity>

Background

- *Life extinct form* (Qld Health intranet only) https://qheps.health.qld.gov.au/__data/assets/pdf_file/0034/2446477/mr41.pdf
- Also see *Information for health professionals* (Qld) https://www.courts.qld.gov.au/__data/assets/pdf_file/0006/92868/m-osc-fs-information-for-health-professionals.pdf

Confirm deceased by checking all the following^{1,2}

- No palpable carotid pulse
- No heart sounds heard for 30 seconds
- No breath sounds heard for 30 seconds
- No response to centralised stimuli
- Fixed dilated pupils

Is this a reportable death

See *Life extinct form* for full definitions

No

- Contact MO + local clinic management, who will advise ongoing management

- Offer condolences to the family + consider/support their needs/wishes about viewing the body³

The death is reportable to the coroner if: ^{1,2}

- Unknown person
- Violent or unnatural, including trauma
- Happened in suspicious circumstances
- Death was healthcare related
- A cause of death certificate not likely to be issued (cause unknown)
- Death in care
- Death in custody or as a result of police operations

Yes or unsure

Immediately report to local Police + contact MO:

- Until advised **do NOT**:¹⁻³
 - move the body. **Note:** if in public place cover body with sheet + protect dignity of the deceased
 - remove medical equipment eg IVCs, catheters
- Notify local clinic management + next of kin (if known/appropriate)
- Police or MO will report the death to the coroner + advise ongoing management which may include completing *Life extinct form*
- Refer to HHS/local policy + procedure

Glasgow Coma Scale/AVPU

A	Alert
V	Responds to voice
P	Responds to painful stimuli
U	Unresponsive

Glasgow Coma Scale (GCS) ^{1,2}				
Eyes open	Spontaneous	4		
	To speech	3		
	To pain	2		
	No response (C= eyes closed)	1		
		Child/infant	Non verbal person (child/infant/adult)	
Best verbal response	Orientated	5	Alert, babbles, coos, words to usual ability	Spontaneous normal facial/oro-motor activity
	Confused	4	Less than usual words, spontaneous irritable cry	Less than usual ability/response to touch only
	Inappropriate words	3	Cries only to pain	Vigorous grimace to pain
	Incomprehensible sounds	2	Moans to pain	Mild grimace to pain
	No response (T=tracheostomy)	1	No response to pain	No response to pain
		Child/infant/non verbal person		
Best motor response	Obeys commands	6	Spontaneous or obeys verbal commands	
	Localises to pain	5		
	Withdraws from pain	4		
	Flexion to pain (decorticate)	3		
	Extension to pain (decerebrate)	2		
	No response	1		
GCS total/15				

- Always act on: score < 15 or drop of ≥ 2
- If < 8 requires secured airway. Consider [LMA](#), p. 56 until patient can be intubated

Injection pain

HMP Managing injection pain

Non-pharmacological strategies¹

- Patients of all ages should have control over how and where they receive their injection
- Short wait time for injection
- Pain blocking techniques - applied to site prior to injection eg:
 - ice pack for 5 minutes
 - firm pressure for 10 seconds
 - ice and vibration:
 - Buzzy® - ice pack for 5 minutes then Buzzy® for 60 seconds and move Buzzy® directly above the site of insertion during injection
 - CoolSense® - use Buzzy® for 60 seconds first, then Coolsense® for 10 seconds, then Buzzy® as above
 - other device eg Shot Blocker® - piece of plastic shaped to fit around the injection site and press the skin with multiple, small, blunt bumps to 'saturate sensory nerves'
- Distraction techniques eg electronic games, videos
- Refrigerate needle prior to injection
- Allow the syringe to reach room temperature before use
- Injecting slowly eg over 2–3 minutes - be guided by the patient

Pharmacological strategies¹

- Paracetamol before injection and at appropriate intervals after. See [Acute pain, p. 32](#)
- Anaesthetic spray/cream before injection eg Emla®. **Note:** only anaesthetises skin, not lower layers
- Nitrous oxide + oxygen (Entonox®) during injection. See [Acute pain, p. 32](#)
- If highly distressed consider consulting MO/NP/RHD (Qld) ☎ 1300 135 854 or state/territory RHD control program for other options
- **Note:** *The Australian ARF/RHD guideline* provides guidance for lidocaine (lignocaine) injected with Bicillin LA® as an option. This is not currently supported in Qld²

S2	Lidocaine (lignocaine) + prilocaine Emla®			Extended authority ATSIHP/IHW
ATSIHP, IHW, MID, RIPRN and RN may proceed				
Form	Strength	Route	Dose	Duration
Cream	Lidocaine 2.5%/ Prilocaine 2.5%	Topical	Adult and child > 6 months Squeeze about 3.5 cm from tube onto intact skin and cover with an occlusive dressing OR apply 1 patch	Leave on skin for 1 hour Remove prior to injection
Patch				
Offer CMI: Effect lasts for 30 minutes to 2 hours after removal. May cause temporary blanching and swelling of the skin				
Contraindication: Methaemoglobinaemia. Use with caution if taking medicines that may cause methaemoglobinaemia eg sulfonamides, nitrates				
Management of associated emergency: Consult MO/NP. See Anaphylaxis, p. 82				3

Ventrogluteal injection

Injection site

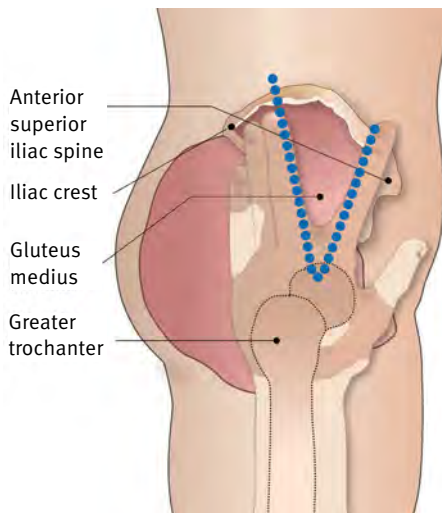

Technique¹

- Place patient in a side-lying position
- Use your right hand on the patient's left hip; or left hand on the patient's right hip:
 - with the palm of your hand, locate the greater trochanter of the femur
 - place your index finger towards the front or anterior superior iliac spine + fan the middle finger as far along the iliac crest as you can reach. The thumb should be pointed towards the front of the leg
- The injection site is in the middle of the triangle between the middle and index fingers
- Remove your fingers prior to inserting the needle
- See video - *Ventrogluteal injection technique*
https://www.youtube.com/watch?v=BIO_hojT5jk&feature=youtu.be

Abbreviations and acronyms

AAA	Abdominal aortic aneurysm
ABCD	Airway Breathing CPR Defibrillation
ACAT	Aged Care Assessment Team
ACE	Angiotensin converting enzyme
ACEI	Angiotensin converting enzyme inhibitors
ACR	Albumin/creatinine ratio
ACS	Acute coronary syndrome
ACWY	Four meningococcal serotypes
AdjBW	Adjusted body weight
ADT	Adult diphtheria and tetanus
AED	Automated external defibrillator
AEFI	Adverse event following immunisation
AF	Atrial Fibrillation
AFB	Acid-fast bacilli
AIH	Australian Immunisation Handbook
AIR	Australian Immunisation Register
ALS	Advanced Life Support
Anti-HBc	Anti-hepatitis B core total antibodies
Anti-HBs	Anti-hepatitis B surface antibody
AOM	Acute otitis media
AMH	Australian Medicines Handbook
AMS	Antimicrobial stewardship
APH	Antepartum haemorrhage
APO	Acute pulmonary oedema
Approx.	Approximately
APSGN	Acute post streptococcal glomerulonephritis
APTT	Activated partial thromboplastin time
ARB	Angiotensin-receptor blocker
ARF	Acute rheumatic fever
ART	Antiretroviral therapy
ASB	Asymptomatic bacteriuria
ASBD	Acute severe behavioural disturbance
ASCIA	Australian Society of Clinical Immunology and Allergy
ASHM	Australasian Society for HIV, Viral Hepatitis and Sexual Health Medicine
ASOT	Anti streptolysin O antibodies

ATSIHP	Aboriginal and Torres Strait Islander Health Practitioner
A&TSIHP	
AVPU	A lert, V oice, P ain, U nresponsive
β-hCG	Beta human chorionic gonadotropin
bd	Twice a day
BBV	Blood borne virus
BCG	Bacille Calmette Guerin
BF	Breastfeeding
BFV	Barmah Forest virus
BGL	Blood glucose level
BiPAP	Bi-level positive airway pressure
BLS	Basic Life Support
BMI	Body mass index
BP	Blood pressure
BPMH	Best possible medication history
BV	Bacterial vaginosis
C ₃	Complement component 3
C ₄	Complement component 4
CATAG	Council of Australian Therapeutic Advisory Group
CATCH	Children's Advice & Transport Coordination Hub
CCG	Clinical Care Guideline
CCM	Chronic Conditions Manual
CCT	Controlled cord traction
<i>C. difficile</i>	<i>Clostridium difficile</i>
CDNA	Communicable Diseases Network Australia
CEWT	Children's Early Warning Tool
CHEM8+	i-STAT cartridge (chemistries/ electrolytes, haematocrit, Hb)
CHEM20	Biochemistry profile
CF	Counting fingers
CGM	Continuous glucose monitoring
CHD	Chronic heart disease
CK	Creatine kinase
CKD	Chronic kidney disease
cm	Centimetre(s)
CMI	Consumer medicine information
CMP	Calcium-magnesium-phosphate
CMV	Cytomegalovirus
CNS	Central nervous system
CO ₂	Carbon dioxide
COCP	Combined oral contraceptive pill

COPD	Chronic obstructive pulmonary disease	EWARS	Early Warning and Response System
CPAP	Continuous positive airway pressure	FAST	Facial weakness, Arm ± weakness, Speech difficulty, Time to act fast
CPLO	Child Protection Liaison Officer	FB	Foreign body
CPR	Cardiopulmonary resuscitation	FBC	Full blood count
CREDD	Children's Resuscitation Emergency Drug Dosage	FCU	First catch urine
CRP	C-reactive protein	ffn	Fetal fibronectin
CRT	Capillary refill time	FHR	Fetal heart rate
CSF	Cerebrospinal fluid	FLACC	Face, Legs, Activity, Cry, Consolability scale
CSOM	Chronic suppurative otitis media	FMH	Fetomaternal haemorrhage
CST	Cervical screening test	FTA	Fluorescent treponemal antibody
CT	Computed tomography	G	Gauge eg 14 gauge
CTG	Cardiotocography	g	Gram
CTPA	CT pulmonary angiogram	Group A Strep (GAS)	Group A <i>Streptococcus</i>
DASS	Depression anxiety stress scales	Group B Strep (GBS)	Group B <i>Streptococcus</i>
dBp	Diastolic blood pressure	GCS	Glasgow Coma Scale
DCI	Decompression illness	GDM	Gestational diabetes mellitus
DEET	Diethyl toluamide	GFR	Glomerular filtration rate
DFV	Domestic and family violence	GHB	Gamma hydroxybutyrate
DKA	Diabetic ketoacidosis	GI	Gastrointestinal
DM	Diabetes mellitus	GIT	Gastrointestinal tract
DMPA	Depot medroxyprogesterone acetate	GORD	Gastro-oesophageal reflux disease
DNA	Deoxyribonucleic acid	GP	General practitioner
dT	Diphtheria-tetanus	GTN	Glyceryl trinitrate
DTPa	Diphtheria-tetanus-acellular pertussis	GXP	GeneXpert machine
dTpa		H ₂ O	Water
DVT	Deep vein thrombosis	Hb	Haemoglobin
ECG	Electrocardiogram	HbA1C	Glycated haemoglobin
Echo	Echocardiogram	HBIG	Hepatitis B immunoglobulin
<i>E. coli</i>	Escherichia coli	HBsAg	Hepatitis B surface antigen
EDD	Estimated date of delivery	HCV	Hepatitis C virus
EDO	Epididymo-orchitis	HCV Ab	Hepatitis C virus antibody
EEA	Emergency examination authority	hep A	hepatitis A
eFAST	Extended focused assessment with sonography in trauma	hep B	hepatitis B
eg	for example	hep C	hepatitis C
EIA	Enzyme-linked immunosorbent assay	HELLP	Haemolysis, Elevated Liver enzymes and Low Platelet count (a variant of severe preeclampsia)
ENT	Ears, nose and throat	HFNC	High flow nasal cannula
EPA	Extended practice authority	HHS	Hyperosmolar hyperglycaemic state
EPDS	Edinburgh Postnatal Depression Scale	Hib	<i>Haemophilus influenzae</i> type B
ESR	Erythrocyte sedimentation rate	HIV	Human immunodeficiency virus
etc	Etcetera	HMP	Health management protocol
eTG	Electronic Therapeutic Guidelines		

HPV	Human papilloma virus
HR	Heart rate - beats/minute
HRF	Hypercapnic respiratory failure
HRT	Hormone replacement therapy
HSV	Herpes simplex virus
HVS	High vaginal swab
IBW	Ideal body weight
ICP	Intracranial pressure
ICU	Intensive care unit
ID	Infectious disease
ID	Identification
I&D	Incision and drainage
IDC	Indwelling catheter
ie	That is
IG	Immunoglobulin
IgG	Immunoglobulin G
IgM	Immunoglobulin M
IHW	Authorised Indigenous Health Worker
IM	Intramuscular
INR	International Normalised Ratio
IOP	Intraocular pressure
IPAP	Isolated Practice Area Paramedic
IPN	Immunisation Program Registered Nurse
i-STAT	Point of care analyser
IUD	Intrauterine device
IUGR	Intrauterine growth restriction
IV	Intravenous
IVC	Intravenous cannula
IVP	Intravenous pyelogram
JIC	Just in case forensic examination
JVP	Jugular venous pressure
kg	Kilogram(s)
kph	Kilometres per hour
L	Litre(s)
LAM	List of Approved Medicines (Qld)
LBBB	Left bundle branch block
LDH	Lactate dehydrogenase
LFT	Liver function test
LGV	Lymphogranuloma venereum
LMA	Laryngeal mask airway
LMP	Last menstrual period
LNMP	Last normal menstrual period
LOC	Level of consciousness
LSD	Lysergic acid diethylamide
LVS	Lower vaginal swab

m	Metre
MAD	Mucosal atomisation device
Mane	Morning
MAO	Monoamine oxidase
MAOI	Monoamine oxidase inhibitor
max.	Maximum
MCS	Microscopy, culture, sensitivity
MDI	Metered dose inhaler
MDMA	Methylenedioxyamphetamine
MEWT	Maternity Early Warning Tool
mg	Milligram(s)
MHAODS	Mental Health, Alcohol and Other Drugs
microg	Microgram(s)
MID	Midwife
MI	Myocardial infarction
mL	Millilitre(s)
mm	Millimetre(s)
mmHg/kPa	Millimetre of mercury/kilopascal
mmol	Millimole(s)
MMR	Measles, mumps, rubella
MO	Medical officer
MRI	Magnetic resonance imaging
MRSA	Methicillin-resistant <i>staphylococcus aureus</i>
msec	Millisecond
MSE	Mental state examination
MSM	Men who have sex with men
MSU	Midstream urine sample
Mths	Months
MToP	Medical termination of pregnancy
NAD	No abnormalities detected
NEB	Nebulised, nebule
NEWT	Neonate Early Warning Tool
NEXUS	National Emergency X-Radiography Utilisation Study
NG	Nasogastric
ng/mL	nanograms/mL
NGT	Nasogastric tube
NIPs	National Immunisation Program schedule
NIPT	Non-invasive pre-natal screening test
nmol	nanomoles/mL
nocte	At night
NP	Nurse practitioner

NSAID	Non-steroidal anti-inflammatory drug	PVD	Peripheral vascular disease
NSTEACS	Non-ST elevation acute coronary syndrome	Q-ADDS	Queensland Adult Deterioration Detection System
NSTEMI	Non-ST elevation myocardial infarction	QAS	Queensland Ambulance Service
NSW	New South Wales	qid	Four times a day
NS1	Nonstructural protein 1	Qld	Queensland
NT	Northern Territory	QCG	Queensland Clinical Guidelines
O ₂	Oxygen	Q-MEWT	Queensland Maternity Early Warning Tool
OGT	Orogastric tube	QSSS	Qld Syphilis Surveillance Service
OGTT	Oral glucose tolerance test	RA	Recommendation for assessment
OM	Otitis media	RBC	Red blood cells
OME	Otitis media with effusion	RBWH	Royal Brisbane Women's Hospital
ORS	Oral rehydration solution	RFDS	Royal Flying Doctor Service
p.	Page	RHD	Rheumatic heart disease
P2/N95	Standards applying to particulate filtering personal masks	Rh D	Rhesus factor (blood group)
Papp-A	Pregnancy associated placental protein-A	RIPRN	Rural and Isolated Practice Registered Nurse
PBS	Pharmaceutical Benefits Scheme	RN	Registered Nurse
PCCM	Primary Clinical Care Manual	RNA	Ribonucleic acid
PCI	Percutaneous coronary intervention	ROA	Right occiput anterior
PCR	Polymerase chain reaction OR Protein/creatinine ratio	ROM	Range of motion
PE	Pulmonary embolism	ROM	Rupture of membrane
PEA	Pulseless electrical activity	ROSC	Return of spontaneous circulation
PEP	Post-exposure prophylaxis	RPR	Rapid plasma reagin test
PHR	Pregnancy health record	RR	Respiratory rate - breaths/minute
PIC	Poisons Information Centre	RRV	Ross River virus
PICC	Peripherally inserted central catheter	RSQ	Retrieval Services Queensland
PID	Pelvic inflammatory disease	S ₂	Schedule 2
PNG	Papua New Guinea	S ₃	Schedule 3
POC	Products of conception	S ₄	Schedule 4
PoCT	Point of care testing	S ₈	Schedule 8
POP	Progestogen only pill	SA	South Australia
PPE	Personal protective equipment	SAIK	Sexual assault investigation kit
PPH	Postpartum haemorrhage	sBP	Systolic blood pressure
PPV	Positive pressure ventilation	SES	State emergency service
PQ	Pathology Queensland	SGLT ₂	sodium-glucose co-transporter 2
PR	Per rectum	SIDS	Sudden infant death syndrome
PrEP	Pre-exposure prophylaxis	SLE	Systemic lupus erythematosus
PROM	Prelabour rupture of membranes	SMO	Senior Medical Officer
prn	As needed	SNRI	Serotonin and norepinephrine reuptake inhibitors
PTH	Parathyroid hormone	SOB	Shortness of breath
PV	Per vagina	SpO ₂	Peripheral oxygen saturation
		SRH	Sexual or reproductive health registered nurse

SSRI	Selective serotonin reuptake inhibitors
Staph	<i>Staphylococcus</i>
stat	Immediately and once only
STEMI	ST-elevation myocardial infarction
STI	Sexually transmitted infection
SToP	Surgical termination of pregnancy
Strep	<i>Streptococcus</i>
Subcut	Subcutaneous
Subling	Sublingual
T	Temperature in degrees celsius
TB	Tuberculosis
TBSA	Total body surface area
TCA	Tricyclic antidepressant
TDM	Therapeutic drug monitoring
tds	Three times a day
TED	Thoracic elevation device
TEMSU	Telehealth Emergency Management Support Unit
TFT	Thyroid function test
TGA	Therapeutic Goods Administration
TIA	Transient ischaemic attack
TIG	Tetanus immunoglobulin
TM	Tympanic membrane
ToP	Termination of pregnancy
<i>T. pallidum</i>	<i>Treponema pallidum</i>
TPHA	Treponema pallidum haemagglutination assay
TPPA	Treponema pallidum particle agglutination assay
TSH	Thyroid stimulating hormone
UC	Urea and creatinine
UE	Urea and electrolytes
UEC	Urea, electrolytes and creatinine
UEG	Urea, electrolytes and glucose
UPA	Ulipristal acetate
URTI	Upper respiratory tract infection
USB	Universal Serial Bus
USS	Ultrasound scan
UTI	Urinary tract infection
UV	Ultraviolet
V	Volt
VA	Visual acuity
VBG	Venous blood gas
VE	Vaginal examination
VF	Ventricular fibrillation
VQ	Ventilation perfusion (scan)

VT	Ventricular tachycardia
VTE	Venous thromboembolism
VZV	Varicella-zoster virus
WA	Western Australia
WCC	White cell count
WOB	Work of breathing
Symbols	
↗	Increasing/increased
↘	Decreasing/decreased
>	Greater than
<	Less than
≤	Less than or equal to
≥	Greater than or equal to
-ve	Negative
+ve	Positive
±	Plus or minus
+	Plus
=	Equal to
®	Registered trade mark
☎	Phone number OR notifiable
%	Percent
°	Degrees
~	About/approximately

Index

A

- Abbreviations.....565
- Abdominal examination 197
- Abdominal injuries..... 150
- Blunt*..... 150
 - Penetrating* 151
 - Pregnant woman with* 151
- Abdominal pain.....196
- Assessment*..... 196
 - Causes* 199
 - Child* 493
 - In female* 462
- Abscess
- Boils*..... 302
 - Breast* 431
 - Incision and drainage* 303
 - Tooth*..... 267
- Abuse/neglect, See Child protection 551
- Acetylcysteine 220
- Acid, burns.....182
- Activated charcoal..... 213
- Acute
- Abdominal pain* 196
 - Asthma* 95
 - Bacterial sinusitis*..... 252
 - Behavioural disturbance* 336
 - Glaucoma* 280
 - Hypertensive emergency*..... 116
 - Iritis* 280
 - Lower leg ischaemia*..... 123
 - Mastoiditis* 521
 - Otitis media* 523
 - Pain* 32
 - Post streptococcal glomerulonephritis*..... 511
 - Pulmonary oedema* 113
 - Retention of urine*..... 208
 - Rheumatic fever* 515
 - Subarachnoid haemorrhage* 127
 - Swollen/painful joint, adult*..... 325
 - Swollen/painful joint, child* 550
 - Wounds*..... 162
- Acute coronary syndrome (ACS) 107
- Clinical pathways, links* 107
 - Indications for reperfusion* 109
 - Primary PCI* 110
 - Thrombolysis at rural or remote facility*..... 110
- Acute post strep glomerulonephritis (APSGN) ... 511
- Acute rheumatic fever (ARF) 515
- Acute severe behavioural disturbance (ASBD) ... 336
- Adrenaline (epinephrine), for anaphylaxis
- Autoinjector*..... 83
 - Doses* 83
 - Epipen, Anapen*..... 83
- Adult presentation
- History and physical examination*..... 17
- Advanced Life Support (ALS) 48
- Algorithms* 51
- Aerosol sniffing 211, 216
- Airway obstruction
- Choking* 78
 - Foreign body*..... 78
- Alcohol
- Poisoning*..... 211, 213
 - Related epigastric pain, see Gastritis*..... 202
 - Withdrawal*..... 356
 - Withdrawal scale*..... 357
- Alkalis, burns 182
- Allergic reaction, mild..... 248
- Allergic reaction, severe, See Anaphylaxis..... 82
- Allergic rhinitis 248
- Altered level of consciousness (LOC) 60
- Possible causes*..... 61
- Amphetamines, overdose 211, 219
- Amputated body part 138
- Anaemia, child 546
- Analgesia 32, 34
- Acute pain*..... 32

Anapen	83	<i>Skin, child</i>	485
Anaphylaxis	82	<i>STI/BBV</i>	445
<i>Adrenaline (epinephrine) doses</i>	83	<i>Trauma</i>	134
<i>Autoinjector</i>	83	Asthma attack	95
Angina.....	107	Asymptomatic bacteriuria, pregnancy	375
Animal bites	173	Asystole	48
Anogenital ulcers/lumps	465	Athletes foot.....	311
Antenatal care.....	364	Atrial fibrillation (AF).....	119
<i>Syphilis, increased/high risk</i>	368	Attempted suicide	
Antepartum haemorrhage (APH)	390	<i>Mental health emergency</i>	336
Anti-D	369	<i>Overdose/poisoning</i>	211, 211
Antiemetics	42	<i>Suicidal behaviour</i>	344
Anxiety	354	<i>Traumatic injuries eg hanging</i>	134
Aortic compression, in PPH	421	AVPU	562
Aortic dissection	104	B	
Apgar score	412	Backslab, how to.....	153
APH, See Antepartum haemorrhage	390	Bacterial sinusitis, acute	252
APO (acute pulmonary oedema).....	113	Bacterial vaginosis (BV).....	457
APSGN.....	511	Barmah Forest virus.....	327
ARF (acute rheumatic fever).....	515	Basic Life Support (BLS)	46
<i>Clinical pathway, link</i>	517	<i>Algorithm</i>	47
<i>Prophylaxis - Bicillin LA injections</i>	330	Bat bite/scratch	176
<i>Symptoms, diagnosis</i>	515	BCG vaccine	555
Arrhythmias.....	119	Behavioural and psychological symptoms, dementia.....	348
Arsenic, poisoning	211, 214	Behavioural disturbance, See Mental health emergency	336
Arterial occlusion, leg.....	123	Bends/decompression illness (DCI)	185
Arterial tourniquet.....	134	Best possible medication history (BPMH)	560
Assault.....	241	<i>High risk medicines</i>	560
<i>Domestic and family violence</i>	241	<i>Medication history checklist</i>	560
<i>Sexual assault</i>	243	BGL, low	91
Assessment		Bicillin LA, injection pain.....	563
<i>Abdominal pain</i>	196	Bicillin LA, rheumatic fever	330
<i>Chest pain</i>	103	Bimanual compression, in PPH	419
<i>Ear</i>	519	Bipolar disorders.....	352
<i>Eye</i>	276	Birth, imminent	
<i>Hydration, adult</i>	200	<i>Apgar score</i>	412
<i>Hydration, child</i>	535	<i>Breech</i>	426
<i>Mental health</i>	336	<i>Care of newborn</i>	412
<i>Mental State Examination (MSE)</i>	339		
<i>Pain</i>	32		
<i>Skin, adult</i>	21		

<i>Cord prolapse</i>	414	Box jellyfish stings	231
<i>Episiotomy</i>	407	BP, See Blood pressure	
<i>Haemorrhage</i>	417	Bradyarrhythmia	120
<i>Neonatal resuscitation</i>	408	Breast abscess.....	431
<i>Preterm baby</i>	409	Breech birth	426
<i>Shoulder dystocia</i>	422	Broken bone, See Fracture	
Bite		Broken rib	140
<i>Animal</i>	173	Broken tooth	257
<i>Bat</i>	176	Bronchiolitis.....	503
<i>Blue-ringed octopus</i>	235	Bronchitis, adult.....	250
<i>Cat</i>	173	Bullrout sting.....	236
<i>Centipede</i>	229	Burns	177
<i>Dog</i>	173	<i>Assessment</i>	177
<i>Funnel-web spider</i>	225	<i>Bitumen</i>	183
<i>Human</i>	173	<i>Burns unit contact details</i>	179
<i>Monkey</i>	176	<i>Cement, phosphorous, petrol</i>	184
<i>Red-back spider</i>	227	<i>Chemical contact</i>	182
<i>Scorpion</i>	229	<i>Hydrofluoric acid</i>	183
<i>Snake</i>	222	<i>Rule of Nines</i>	178
<i>Spiders, other</i>	228	<i>Severe</i>	179
<i>Tick</i>	230	<i>Total body surface area %</i>	178
Bitumen, burn	182	Button battery ingestion/insertion	80
Bleeding		<i>Be button battery aware</i>	481
<i>After birth</i>	417	<i>Suspect if</i>	80
<i>Ectopic pregnancy</i>	371	Buzzy	563
<i>GI</i>	203	BV, See Bacterial vaginosis.....	457
<i>Nose</i>	190	C	
<i>Postnatal</i>	429	Caffeine, poisoning	211, 215
<i>Post tooth extraction</i>	270	Candidiasis	
<i>Pregnancy, after 20 weeks</i>	390	<i>Oral</i>	274
<i>Pregnancy, early</i>	373	<i>Skin</i>	313
<i>Rectal</i>	204	<i>Vaginal</i>	458
Blood borne virus (BBV)	445	Carbon monoxide inhalation	215
Blood pressure		Carbuncles	302
<i>High</i>	116	Cardiac arrest.....	46
<i>In children</i>	513	Cardiac arrhythmias	119
Blood sugar level, low	91	Cardiac clinical pathways links.....	107
Blood under nail.....	168	Cardiopulmonary resuscitation (CPR).....	46
Bluebottle and other jellyfish stings.....	234	Carditis, child (See ARF)	515
Blue-ringed octopus.....	235		
Boils.....	302		
<i>Incision and drainage</i>	303		
Bone/joint infection, child	550		
Bowel obstruction	205		

Catastrophic haemorrhage	
<i>Haemostatic dressing</i>	134
<i>Tourniquet</i>	134
Cat bite.....	173
Caustic and corrosive substance ingestion/ poisoning.....	211, 215
Cellulitis	
<i>Orbital/periorbital</i>	288
<i>Skin</i>	306
Cement, burn.....	182
Centipede bites.....	229
Cervical spine immobilisation.....	147
Cervical spine injury.....	147
Charcoal, activated.....	213
Chemical burn	
<i>Contact, skin</i>	182
<i>Eyes</i>	285
Chest pain	
<i>Assessment</i>	103
<i>Causes, other</i>	105
<i>Differential diagnosis</i>	103
<i>Life-threatening causes</i>	104
<i>Possible cardiac</i>	107
Chest wound/injuries.....	140
<i>Blunt trauma</i>	140
<i>Penetrating trauma</i>	141
<i>Pneumothorax</i>	141
Child	
<i>Button battery aware</i>	481
<i>Consider serious illness if</i>	480
<i>Could this be sepsis</i>	481
<i>Differential diagnosis</i>	488
<i>Abdominal pain</i>	493
<i>Cough</i>	490
<i>Fever</i>	489
<i>High BP (consider APSGN)</i>	512
<i>Limp/joint pain (also see ARF)</i>	550, 551
<i>Sore throat</i>	495
<i>Stridor</i>	491
<i>Vomiting</i>	492
<i>Estimated weight (kg) based on age</i>	49
<i>History and physical examination</i>	480
Child protection.....	551
<i>Reporting to Child Safety</i>	552
Chlamydia.....	452
Chlamydial conjunctivitis.....	292
Choking.....	78
<i>Flowchart</i>	79
Cholesteatoma.....	522
Chroming.....	216
Chronic condition medicines, supply by A&TSIHP/ IHW.....	332
Chronic suppurative otitis media (CSOM).....	529
Chronic wounds.....	323
Ciguatera poisoning.....	239
Clenched fist injury.....	173
Clinical consultation.....	25
Cocaine, overdose.....	211, 217
Cold, common.....	250
<i>Adult</i>	250
<i>Child</i>	494
Collapsed patient.....	46
Collecting wound swab.....	324
Compartment syndrome.....	160
Compound fractures.....	154
Condylomata lata.....	466
Cone shell envenomation.....	235
Conjunctivitis	
<i>Allergic</i>	291
<i>Bacterial</i>	291
<i>Chlamydial</i>	292
<i>Gonococcal</i>	291
<i>Trachoma</i>	293
<i>Viral</i>	291
Conscious state	
<i>Altered level of</i>	60
<i>Unconscious</i>	60
<i>Glasgow Coma Scale/AVPU</i>	562
Constipation, child.....	542
Contacts, See Qld contacts	
Contact tracing.....	450
Continuous positive airway pressure (CPAP).....	55
Contraception.....	438
<i>Combined oral contraceptive pill</i>	440

<i>Depo-provera</i>	439	Dementia, with severe behavioural symptoms ..	348
<i>Emergency</i>	443	Dengue fever	327
<i>Medroxyprogesterone acetate</i>	439	Dental, See Tooth	
<i>Options/types</i>	438	Depo-provera	439
<i>Progestogen only pill</i>	442	Depression.....	352
Controlled cord traction	404	Diabetes	
Convulsions	86	<i>Foot infection in</i>	321
<i>Febrile</i>	88	<i>Hyperglycaemia</i>	89
CoolSense.....	563	<i>Hypoglycaemia</i>	91
Coral cut.....	170	<i>In pregnancy</i>	378
Cord prolapse.....	415	<i>Ketoacidosis (DKA)</i>	89
Corneal abrasion	283	<i>Osteomyelitis</i>	321
Corneal ulcer	280	Diabetic ketoacidosis (DKA)	89
Cough, child	490	Diarrhoea/vomiting	
COVID-19	16	<i>Adult</i>	200
CPAP	55	<i>Child</i>	535
CPR	46	Digital nerve block.....	166
Criteria for early notification of trauma, See Front cover insert		Discharging ears	529
Croup	500	Dislocations	158
Crusted (Norwegian) scabies.....	317	<i>Shoulder</i>	158
C-spine immobilisation	147	Dog bite	173
Cyanide, poisoning	211, 215	Domestic and family violence (DFV)	241
Cystitis		<i>Contacts/referrals</i>	243
<i>Adult</i>	295	Donovanosis	467
<i>In pregnancy</i>	375	Drowning.....	101
D		DRSABCD resuscitation	46
DCI/bends.....	185	DRSCABCD, in trauma	134
Death, in absence of MO	561	Drug-induced psychosis.....	350
Decay, tooth	263	Dry perforation, eardrum	531
Decompression illness (DCI/bends)	185	Dry socket	271
Deep vein thrombosis (DVT)	124	DTs (delirium tremens)	356
De-escalation, of agitated person.....	337	DV, See Domestic and family violence	241
Dehydration		DVT	124
<i>Adult</i>	200	E	
<i>Child</i>	535	Eardrum	
Delirium	131	<i>Attic area</i>	521
Delirium tremens (DTs)	356	<i>Bulging, See AOM</i>	523
		<i>Dry perforation</i>	531
		<i>Normal</i>	521

- Traumatic rupture*..... 193
- Ears
- Acute otitis media (AOM)*..... 523
 - Assessment*..... 519
 - Cholesteatoma*..... 522
 - Chronic suppurative otitis media (CSOM)* ... 529
 - Cleaning, tissue spears* 530
 - Differential diagnosis*.....521
 - Dry perforation*.....531
 - Ear drops advice*..... 533
 - Otitis externa (OE)* 532
 - Otitis media with effusion (OME)* 528
 - Mastoiditis*.....521
 - Preventing infections*..... 519
- Ear wick, how to533
- Eclampsia 386
- Magnesium sulfate* 388
- Ectopic pregnancy..... 371
- Electrocution/electric shock..... 121
- Emergency contraception.....443
- Emla cream/patch.....563
- Endone36
- Entonox
- Acute pain*..... 39
 - Labour*402
- Envenomation, See Bites
- Epididymo-orchitis459
- Epigastric pain, See Chest pain assessment.....103
- Epiglottitis..... 510
- Epipen.....83
- Episiotomy407
- Epistaxis.....190
- Epstein-Barr virus 496
- Essential oils, poisoning211, 216
- Evacuation, See Retrieval/evacuation
- Exposure to cold, See Hypothermia.....186
- Eyes
- Assessment*..... 276
 - Chemical burn*..... 285
 - Corneal abrasion*..... 283
 - Differential diagnosis*.....280
 - Everting eyelid*..... 279
 - Examination* 277
 - Flash burn*..... 284
 - Fluorescein*..... 278
 - Foreign body*..... 281
 - Hyphaema* 277
 - Injury - blunt/penetrating*..... 286
 - Laser exposure* 280
 - Orbital/periorbital cellulitis* 288
 - Pupils, eye movements*..... 278
 - Single red*..... 280
 - Sudden, painless loss of vision*..... 287
 - Tips*..... 276
 - Visual acuity*..... 278
- EZ-IO59
- F**
- FACES pain scale33
- Febrile convulsion 88
- Fentanyl38
- Fetal fibronectin (fFN) testing 398
- Fever
- In child*..... 489
 - Treating*..... 489
- First catch urine (FCU)..... 449
- Fish hook, removal of.....169
- Fish stings236
- Fitting..... 86
- In pregnancy*..... 386
 - Post seizure*..... 86
- FLACC pain scale33
- Flail chest140
- Flash burn to eye 284
- Flu, adult250
- Fluorescein, eye examination278
- Fluoride varnish 264
- Folliculitis.....302
- Foot infection, diabetes..... 321
- Osteomyelitis* 321
- Foreign body (FB)
- Ear* 194
 - Eye* 281

Nose	194	Gout	326
Fracture		Group B Strep in pregnancy.....	395
<i>Backslab</i>	153	<i>Antibiotics during labour</i>	395
<i>Base of skull</i>	136	<i>Risk factors</i>	395
<i>Jaw</i>	157	<i>Swab, how to take</i>	393
<i>Limbs</i>	152	Gum disease	272
<i>Open (compound)</i>	154	<i>Gingivitis</i>	272
<i>Pelvis</i>	156	<i>Necrotising gingivitis</i>	272
<i>Plaster care advice</i>	153	<i>Periodontitis</i>	272
<i>Rib(s)</i>	140	H	
<i>Skull</i>	143	Haematemesis	203
<i>Spine</i>	147	Haemoglobin (Hb) ranges, child.....	546
Funnel-web spider bite.....	225	Haemorrhage	
G		<i>After birth/postpartum (PPH)</i>	417
Gamma-hydroxybutyrate (GHB)		<i>Antepartum</i>	390
<i>Overdose</i>	211, 216	<i>Arterial tourniquet</i>	134
Gastritis.....	202	<i>Epistaxis</i>	190
Gastroenteritis		<i>Haemostatic dressing</i>	134
<i>Adult</i>	200	<i>In trauma</i>	134
<i>Child</i>	535	<i>Rectal</i>	204
Gastrointestinal (GI) bleeding, upper	203	<i>Secondary postpartum</i>	429
GBS swab, how to	393	<i>Shock</i>	62
GCS	562	<i>Upper GI</i>	203
Genital herpes.....	472	Haemothorax	140
Genital ulcers/lumps.....	465	Hallucinations/delusions.....	336
<i>Common causes</i>	466	Hallucinogens, overdose.....	211, 216
Genital warts	474	Hand, foot and mouth disease	496
Gestational diabetes	378	Hanging	
<i>OGTT</i>	379	<i>Assessment, See Traumatic injuries</i>	134
<i>Screening and diagnosis</i>	378	<i>Mental health emergency</i>	336
Giardiasis.....	538	Hansen's disease.....	315
GI bleed, upper	203	Hay fever	248
Gingivitis.....	272	Headache.....	127
Glandular fever.....	496	<i>Assessment of</i>	127
Glasgow Coma Scale (GCS)	562	<i>Meningitis</i>	72
Glaucoma, acute	280	<i>Migraine</i>	129
Glue ear	528	<i>Subarachnoid haemorrhage</i>	127
Glue (skin), See Tissue adhesive	167	<i>Sudden onset severe</i>	127
Glue, sniffing.....	211, 216	<i>Tension type</i>	129
Gonorrhoea.....	452	<i>Thunderclap</i>	127
		Head injuries.....	143
		<i>Advice</i>	146

- Risk factors - adult*..... 144
Risk factors - child 144
- Head lice/nits..... 319
- Heart attack, See Acute coronary syndrome..... 107
- Heart failure, See APO 113
- Heart murmur, See ARF..... 515
- Heart rate/rhythm, abnormal
Arrhythmias 119
Asystole 48
Atrial fibrillation (AF) 119
Bradycardia 120
Pulseless Electrical Activity (PEA) 48
Tachycardia 119
Ventricular fibrillation (VF)..... 48
Ventricular tachycardia (VT)..... 48
- Heat stroke/exhaustion..... 188
- Heel prick, baby (how to)..... 414
- Hepatitis
Hep A 451
Hep B 451
Hep C 451
Hep C risk factors..... 447
- Herpes, genital..... 472
- History and physical examination
Adult..... 17
Child 480
- HIV
Antiretroviral therapy (ART)..... 476
Positive test..... 477
Post-Exposure Prophylaxis (PEP)..... 477
Pre-Exposure Prophylaxis (PrEP)..... 477
Testing for..... 476
- Hives 248
- Human immunodeficiency virus (HIV) 476
- Human papilloma virus (HPV)..... 474
- Hydration assessment
Adult..... 200
Child 535
- Hydrofluoric acid
Burn..... 182
Poisoning..... 211, 217
- Hyperglycaemia, See DKA 89
- Hyperosmolar hyperglycaemic state (HHS)..... 89
- Hypertension
BP, normal values in child 513
Emergency..... 116
In pregnancy..... 383
- Hyperthermia 188
- Hyphaema..... 277
- Hypoglycaemia..... 91
In pregnancy..... 382
Newborn 414
- Hypothermia 186
- I**
- i-gel airway..... 56
- IM injection, max. mL 67
- Immediate care of newborn See Care of newborn
- Imminent birth 403
- Immunisations, adult/child..... 554
Tetanus 557
- Immunocompromised
Adult..... 19
Child 483
- Impetigo..... 298
- Implanon, See Contraception
- Incision and drainage, boil..... 303
- Infected scabies 298
- Influenza, adult 250
- Injection pain, managing..... 563
- Injuries
Abdominal 150
Chest..... 140
Eye 286
Finger tip, crush/amputation..... 168
Fracture, limb(s)..... 152
Head 143
Laceration/acute wound..... 162
Pelvis 156
Spinal 147
Sprains/soft tissue injury..... 159
Traumatic..... 134
- Insect in ear, See Foreign body, ear
- Intra cranial pressure, raised 143

Intraosseous access, how to	57	Leprosy	315
<i>EZ-IO</i>	59	Lightning strike	121
<i>Manual insertion</i>	59	LMA, insertion	56
<i>Sites</i>	58	<i>i-gel</i>	56
Intussusception	545	Log roll, how to	148
Involuntary assessment	338	Loss of vision, sudden	287
IO, See Intraosseous access	57	Løvsett's manoeuvre	427
Iritis, acute	280	Low abdominal pain, female	462
Iron, overdose	211, 217	Lymphogranuloma venereum (LGV)	467
Irrigation, eye	285	Lyssavirus	176
Irukandji jellyfish sting	233		
Ischaemia, lower leg	123	M	
ISOBAR	25	Magnesium sulfate drug box	
IUD, See Contraception options	438	<i>In pregnancy</i>	388
		Major burns	177
J		Malaria	327
Jaw fracture	157	Managing injection pain	563
Jellyfish stings		Mandatory reporting, See Child protection	551
<i>Bluebottle</i>	234	Manual removal, placenta	421
<i>Box</i>	231	Marine injury, penetrating	236
<i>Irukandji</i>	233	Marine lacerations, See Water related wounds ..	170
<i>Other</i>	234	Mastitis	431
Jock itch	311	Mastoiditis, acute	521
Joint, painful/swollen		Mauriceau-Smellie-Veit manoeuvre	428
<i>Adult</i>	325	McRoberts (for shoulder dystocia)	422
<i>Child</i>	550	Medication history, best	560
		Medicines, supply	
K		<i>A&TSIHP</i>	332
Kidney stones	206	<i>IHW</i>	332
		<i>RIPRN (Qld)</i>	11
L		<i>RN</i>	11
Labour		Medroxyprogesterone acetate	439
<i>1st stage</i>	400	Melaena	204
<i>2nd stage/birth</i>	403	Melioidosis (pneumonia)	
<i>Group B Strep prophylaxis in</i>	395	<i>Adult</i>	253
<i>Preterm</i>	397	<i>Child</i>	506
Laceration, See Acute wounds	162	Meningitis	72
Laryngeal mask airway (LMA), insertion	56	Mental health emergency	336
Lead, poisoning	211, 217	<i>Bipolar</i>	352
Leg ischaemia, acute	123		

- De-escalation, of agitated person*..... 337
- Depression*..... 352
- Forms (Qld)*
- Emergency Examination Authority* 336
 - Recommendation for Assessment*.. . . 338
 - Request for Police Assistance* 338
- Mental health team, response time*..... 343
- Mental State Examination (MSE)*..... 339
- Non consenting or uncooperative patient* ... 338
- Panic attack*..... 354
- Police assistance*..... 338
- Psychosis*..... 350
- Safety, of staff*..... 337
- Sedation, of agitated person* 340
- Suicidal behaviour* 344
- Mental State Examination (MSE)339
- Methanol, poisoning.....211, 219
- Methoxyflurane39
- M. genitalium452
- Migraine.....129
- Miscarriage373
- MI, See Myocardial infarction 107
- Missed pill
- Combined oral contraceptive pill* 441
 - Progestogen only pill*..... 442
- Molluscum contagiosum467
- Mood, disorders.....352
- Morning after pill.....443
- Morphine37
- Mosquito borne diseases.....327
- Barmah Forest virus* 327
 - Dengue fever*..... 327
 - Malaria* 327
 - Ross River virus* 327
- Mouth ulcers265
- MSE, See Mental State Examination339
- Mycoplasma genitalium452
- Myocardial infarction.....107
- N**
- Nail
- Blood under*..... 168
 - Fungal infection* 311
- Naloxone
- Acute pain*..... 39
 - In overdose* 221
- Nappy rash.....320
- Nasal packing 191
- Nausea and vomiting 40
- Near drowning, See Drowning 101
- Needle decompression/thoracocentesis..... 141
- Neonatal resuscitation 408
- Neutropenic sepsis pathway - child 64
- Newborn
- Apgar score*..... 412
 - Care of* 412
 - Heel prick, how to*..... 414
 - Hypoglycaemia* 414
 - Life support flowchart*..... 410
 - Preterm* 409
 - Resuscitation* 408
- NEXUS criteria148
- Nicotine, poisoning.....211, 218
- Nits/head lice 319
- Norwegian scabies.....316
- Nose bleed.....190
- NSAID, overdose211, 218
- NSTEACS107
- NSTEMI107
- O**
- OGTT379
- Oesophageal varices.....203
- Open (compound) fractures 154
- Opioid, overdose..... 211, 218
- Oral contraceptive pill, combined..... 440
- Oral thrush274
- Orbital/periorbital cellulitis..... 288
- Organophosphates, poisoning.....211, 218
- Osteomyelitis *In diabetic foot* 321
- Otitis externa (OE)532

Otitis media, acute (AOM)	523	Patient presentation - adult and child	16
Otitis media, chronic suppurative (CSOM).....	529	<i>Rapid assessment</i>	16
Otitis media, with effusion (OME).....	528	PE.....	125
Overdose, medicines/other	211, 213	Pelvic binder, how to	156
Oxycodone	36	Pelvic inflammatory disease (PID)	462
Oxygen	53	Pelvis, fractured	156
<i>In COPD</i>	53	Penetrating marine injuries	236
<i>Masks, nasal prongs</i>	54	Penile discharge.....	452
<i>Specific scenarios</i>	53	Pericardial tamponade	104
P		Pericarditis	104
Paediatric presentation		Periorbital cellulitis	288
<i>Be button battery aware</i>	481	Pertussis	508
<i>Could this be sepsis</i>	481	<i>Immunisation</i>	554
<i>Differential diagnosis</i>	488	<i>Immunisation in pregnancy</i>	366, 367
<i>History and physical examination</i>	480	Pesticides or insecticides, poisoning	211, 218
<i>Risk signs, serious illness</i>	480	Petechial rash	72
Pain.....	32	Petrol	
<i>Abdominal</i>	196	<i>Burn</i>	182
<i>Acute</i>	32	<i>Sniffing</i>	211, 216
<i>Analgesia</i>	34	Pharyngitis, See Sore throat	495
<i>Assessment scales</i>	33	Phosphorus, burn	182
<i>Chest</i>	103	Physical restraint (avoiding)	337
<i>Ear</i>	519	PIC, Poisons Information Centre	211
<i>Eye</i>	276	PID, See Pelvic inflammatory disease.....	462
<i>Management</i>	33	Pityriasis versicolor.....	314
<i>Renal colic/kidney stones</i>	206	Placenta	
<i>Sedation score</i>	35	<i>Delivery of</i>	404
<i>Testicular/scrotal</i>	209	<i>Manual removal of</i>	421
Pain relief		<i>Checking</i>	406
<i>Step wise approach</i>	34	Plaster backslab, how to/care of	153
<i>When giving injection</i>	563	Pneumonia	
Panic attack.....	354	<i>Adult</i>	253
Paracetamol.....	36	<i>Child</i>	506
<i>Overdose</i>	211, 218	Pneumothorax	
<i>Safe use</i>	36	<i>Haemothorax</i>	140
Paralysis tick	230	<i>Open</i>	141
Paraquat, poisoning.....	211, 216	<i>Simple</i>	140
Past history, obtaining		<i>Tension</i>	140
<i>Adult</i>	19	Poisoning and overdose.....	211
<i>Child</i>	483	<i>Activated charcoal</i>	213
Pathology, ordering (Qld)	23		
Patient death in absence of MO	561		

- Amphetamines..... 219
- Arsenic..... 214
- Assessment, initial.....211
- Caffeine.....215
- Carbon monoxide.....215
- Caustic/corrosive substances.....215
- Ciguatera 239
- Cocaine..... 219
- Coolants, antifreeze, brake fluids, solvents. 219
- Cyanide.....215
- Essential oils..... 216
- Gamma-hydroxybutyrate (GHB)..... 216
- Hallucinogens..... 216
- Herbicides eg paraquat..... 216
- Hydrofluoric acid.....217
- Iron217
- Lead.....217
- Medicines 213
- Methanol 219
- Naloxone..... 221
- Nicotine..... 218
- Opioids 218
- Paracetamol..... 218
- Pesticides/insecticides..... 218
- Petrol, fuels, oils..... 216
- Poisons Information Centre (PIC)211
- Rat and mouse poison..... 219
- Stimulant drugs 219
- Toxicology assessment..... 212
- Poisons Information Centre (PIC)..... 211
- Postictal..... 86
- Postnatal check.....434
- Postnatal psychosis350
- Postpartum haemorrhage (PPH)
- Primary*.....417
- Secondary*.....429
- Post seizure..... 86
- Post streptococcal glomerulonephritis, acute (APSGN)511
- PPH, See Primary postpartum haemorrhage..... 417
- PR bleeding..... 204
- Preeclampsia/eclampsia..... 386
- Magnesium sulfate* 388
- Pregnancy
- Antenatal care*..... 364
- Asymptomatic bacteriuria (ASB)*..... 375
- Diabetes in*..... 378
- Ectopic* 371
- Fitting in (eclampsia)*..... 386
- Group B Strep*..... 395
- GBS swab, how to*..... 393
- Prophylaxis*..... 395
- Risk factors*..... 395
- Hypertension in*..... 383
- Hypoglycaemia in* 382
- Labour*
- 1st stage*..... 400
- Preterm*..... 397
- Leaving community, planning* 364
- Neonatal resuscitation* 408
- OGTT*..... 379
- Rh D immunoglobulin* 369
- Rupture of membranes, before labour*..... 392
- Syphilis, increased/high risk of*..... 368
- Syphilis, treatment in* 470
- Urinary tract infection in* 375
- Pregnancy, bleeding
- After 20 weeks*..... 390
- Before 20 weeks*..... 373
- Pressure bandage, snake bite223
- Preterm baby, care of..... 409
- Preterm labour397
- Fetal fibronectin (fFN) testing*..... 398
- Preterm prelabour rupture of membranes, See PROM.....392
- Primary and secondary survey, trauma 134
- Primary postpartum haemorrhage (PPH) 417
- PROM, See Prelabour rupture of membranes.....392
- Psychosis/psychotic disorders.....350
- Pulmonary embolism (PE) 125
- Pulmonary oedema, acute (APO)..... 113
- Pulseless Electrical Activity (PEA) 48
- Pyelonephritis
- Adult*..... 295
- In pregnancy*..... 375
- Pyloric stenosis544

Q	
Q Fever vaccine	555
Qld contacts	
<i>Burns units</i>	179
<i>Child Safety</i>	552
<i>RFDS</i>	24
<i>RSQ</i>	24
<i>TEMSU</i>	24
Quick-Wee.....	549
Quinsy.....	495
R	
Rabies.....	176
Raised intra cranial pressure, signs	143
Rape, See Sexual assault	243
Rapid assessment, patient.....	16
Rat/mouse poison	211, 219
Recreational drugs, overdose	211
Rectal bleeding	204
Red-back spider bite	227
Red eye(s)	280
Renal colic.....	206
Reperfusion options, ACS.....	109
Reportable death	561
Retention of urine, acute	208
Retrieval/evacuation	26
<i>Preparation</i>	27
<i>Who to contact</i>	26
Retrieval Services Queensland (RSQ)	24
Rh D immunoglobulin	369
Rheumatic fever, acute (ARF).....	515
<i>Bicillin LA injections (prophylaxis)</i>	330
Rhinitis, allergic	248
Rib, broken.....	140
Ring, removal of	170
Ringworm.....	311
RIPRN	11
<i>Order pathology (Qld)</i>	23
<i>Qld EPA</i>	11
<i>Supplying medicines</i>	11
<i>Victoria</i>	11
RN supplying (medicines)	11
Ross River virus	327
Royal Flying Doctor Service.....	24
RSQ.....	24
Rule of nines, burns	178
Rupture of membranes, prelabour.....	392
S	
Scabies	316
<i>Crusted (Norwegian)</i>	316
<i>Infected</i>	298
Scarlet fever	496
Schizophrenia.....	350
School sores, See Impetigo.....	298
Scorpion stings	229
Scrotal pain.....	209
Sea snake bite.....	222
Sea urchin sting	236
Secondary postpartum haemorrhage (PPH)	429
Secondary survey, trauma	135
Second skin, See Tinea versicolor	314
Sedation score, pain	35
Seizures	86
Self-harm, See Mental health emergency	336
Sepsis/septic shock.....	64
<i>Neutropenic sepsis pathway - child</i>	64
<i>Risk factors</i>	65
<i>Rural/remote sepsis pathways</i>	64
<i>Screen for</i>	64
Septic arthritis, child	550
Sexual assault/abuse - adult/child	243
Sexually transmitted infections (STI)	445
<i>Assessment, STI/BBV</i>	445
<i>Asymptomatic check-up</i>	446
<i>Bacterial vaginosis (BV)</i>	457
<i>Chlamydia</i>	452
<i>Contact tracing</i>	450
<i>Epididymo-orchitis</i>	459
<i>Flowchart</i>	451

- Contact of person with STI/BBV 451
 Positive pathology test..... 451
 Symptoms of an STI..... 451
 Gonorrhoea..... 452
 Hepatitis A, B, C.....451
 Herpes..... 472
 HIV..... 476
M. genitalium..... 452
 Pathology..... 448
 Penile discharge 452
 Self collected swabs/urine..... 449
 Syphilis 468
 Tests, STI/BBV 448
Trichomonas..... 452
 Ulcers/lumps, anogenital..... 465
 Vaginal discharge 452
 Warts 474
 Shingles.....309
 Shock.....62
 Causes..... 63
 Signs of..... 62
 Shoulder dystocia422
 Sinusitis, bacterial 252
 Skin assessment
 Adult.....21
 Child..... 485
 Skin glue, See Tissue adhesive 167
 Skin sores, infected.....298
 Snake bite.....222
 Pressure bandage..... 223
 Sniffing, petrol, glue, aerosol 211, 216
 Sore throat495
 Spider bite
 Funnel-web (big black)..... 225
 Other..... 228
 Red-back..... 227
 Spinal injuries..... 147
 Moving patient.....149
 Sponge sting.....238
 Sprains/soft tissue injury..... 159
 Status epilepticus86
 STEMI..... 107
 STI, See Sexually transmitted infections
 Stimulant drugs, overdose 211, 219
 Stinging tree.....240
 Stingray injury236
 Stings
 Bluebottle 234
 Blue-ringed octopus..... 235
 Box jellyfish 231
 Centipede..... 229
 Cone shell 235
 Fish 236
 Irukandji 233
 Other jellyfish..... 234
 Scorpion 229
 Sea urchins 236
 Sponges..... 238
 Stinging tree 240
 Stonefish sting.....236
 Strangulation, eye signs.....280
 Stridor, in child..... 491
 Stroke 130
 Strongyloides, See Worms 540
 Subarachnoid haemorrhage, acute..... 127
 Submersion/drowning 101
 Subungual (under nail) haematoma..... 168
 Sucking chest wound141
 Suicide/attempted
 Mental health emergency..... 336
 Overdose/poisoning 211
 Suicidal behaviour 344
 Traumatic injuries eg hanging..... 134
 Supply, chronic medicines by A&TSIHP/IHW 332
 Supply medicines, RN/RIPRN11
 Supraglottic airway eg LMA56
 Suspected acute coronary syndrome clinical pathway 108
 Suturing166
 Swimmer's ear, See Otitis externa 532
 Swollen/painful joint
 Acute rheumatic fever..... 515
 Adult..... 325
 Child 550
 Sydenham chorea 516

Syphilis	468	<i>Dry socket</i>	271
<i>Contact tracing</i>	470	<i>Fluoride varnish</i>	264
<i>In pregnancy</i>		<i>Knocked out</i>	257
<i>Increased/high risk</i>	368	<i>Post extraction bleeding</i>	270
<i>Treatment</i>	470	<i>Replant knocked out</i>	258
<i>Pathology interpretation</i>	469	<i>Trauma</i>	257
Syphilis Surveillance Service (Qld) (QSSS)	468	Toothache	261
		<i>Common causes</i>	262
T		Tooth-knuckle injury.....	173
Tachyarrhythmia.....	119	ToP, See Termination of pregnancy	362
Tazer gun.....	121	Torsion of testes	209
TB.....	255	Tourniquet, haemorrhage control	134
Teeth See Tooth		Toxicology assessment.....	211
TEMSU/telehealth	24	Trachoma	293
Tenecteplase.....	111	Tranexamic acid, drug box.....	139
Tension pneumothorax	140	Transient ischaemic attack (TIA)	130
Termination of pregnancy.....	362	Trauma, criteria for early notification See Front cover insert	
Testicular/scrotal pain.....	209	Traumatic injuries.....	134
Testicular torsion.....	209	<i>Abdominal</i>	150
Tetanus		<i>Amputated body part</i>	138
<i>Booster</i>	557	<i>Chest</i>	140
<i>Immunisation</i>	557	<i>Dislocations</i>	158
<i>Prone wound</i>	557	<i>Head</i>	143
Throat, sore.....	495	<i>Jaw</i>	157
Thrombolysis, at rural or remote facility.....	110	<i>Limb fractures/splinting</i>	152
<i>Tenecteplase</i>	111	<i>Moving patient</i>	149
Thrush		<i>Log roll, how to</i>	149
<i>Oral</i>	274	<i>Open fractures</i>	154
<i>Skin</i>	313	<i>Pelvis fracture</i>	156
<i>Vaginal</i>	458	<i>Pregnant woman with</i>	138
TIA.....	130	<i>Primary/secondary survey</i>	134
Tick bites.....	230	<i>Spinal</i>	147
<i>Paralysis</i>	230	<i>Tourniquet, catastrophic haemorrhage</i>	134
Tinea	311	<i>Tranexamic acid</i>	139
<i>Versicolor</i>	314	Traumatic rupture of eardrum	193
Tissue adhesive	167	Trichomonas	452
Tissue spears, how to.....	530	Tropical ear.....	532
Tonsillitis.....	495	Tuberculosis (TB).....	255
Tooth		Tuning fork, hearing test.....	193
<i>Abscess</i>	267		
<i>Broken/loose from trauma</i>	257		

- U**
- Ulcer
- Chronic/non healing wound*..... 323
 - Corneal*280
 - Genital*..... 465
 - Mouth*..... 265
- Umbilical cord prolapse 415
- Unconscious patient60
- Possible causes*..... 61
- Unstable angina 107
- Upper respiratory tract infection (URTI)
- Adult*..... 250
 - Child*..... 494
- Urinary retention, acute.....208
- Urinary tract infection (UTI)
- Adult*..... 295
 - Child*..... 548
 - In pregnancy*.....375
- URTI, See Upper respiratory tract infection
- Urticaria248
- Uterine inversion..... 421
- UTI, See Urinary tract infection
- V**
- VA278
- Vaccines..... 554
- Vaginal bleeding
- After 20 weeks pregnancy*..... 390
 - Before 20 weeks pregnancy*.....373
 - Ectopic pregnancy*.....371
 - Primary postpartum haemorrhage (PPH)*.....417
 - Secondary postpartum haemorrhage (PPH)* 429
- Vaginal discharge..... 452
- Ventricular fibrillation (VF)48
- Ventricular tachycardia (VT).....48
- Ventrogluteal injection, how to..... 564
- Vision, sudden loss.....287
- Visual acuity (VA)278
- Vital signs, normal
- Adult*.....17
 - Child*.....480
 - Child BP*.....513
- Vitamin K, for newborn 413
- Voltage, high121
- Vomiting.....40
- Assessment of*..... 40
 - Blood* 203
 - Child, causes*..... 492
 - Coffee grounds*..... 203
 - Nausea* 40
 - With diarrhoea, adult* 203
 - With diarrhoea, child*.....535
- W**
- Warts, anogenital.....474
- Water related wounds 170
- Waters broken, pregnancy.....392
- Weight (kg) based on age - child.....49
- Wells score
- DVT suspected*.....124
 - for PE* 126
- Wernicke encephalopathy..... 356
- Whooping cough508
- Worms.....540
- Wounds
- Acute*..... 162
 - Care, dressings (chronic)*..... 324
 - Chronic* 323
 - Coral cut*.....170
 - Gravel rash*.....163
 - Repair* 162
 - Special sites/considerations*.....167
 - Water related*.....170
- Wound swab, how to 324
- X**
- Y**
- Z**

Notes

Notes

Anaphylaxis¹

ANY ONE of the following could indicate anaphylaxis

- Difficult/noisy breathing
- Wheeze or persistent cough
- Swelling of tongue
- Persistent dizziness or collapse
- Swelling/tightness in throat
- Pale and floppy (young children)
- Difficulty talking/hoarse voice
- Vomiting and/or abdominal pain - for insect stings/bites
- **Any acute onset:** hypotension, bronchospasm or upper airway obstruction, OR illness with skin features + respiratory/cardiovascular or persistent severe GI symptoms

IMMEDIATE ACTION

- Remove allergen if still present
- Call for help
- Lay patient flat - do not allow to stand

Give intramuscular ADRENALINE (EPINEPHRINE) without delay
Deep IM into outer mid-thigh
Repeat 5 minutely as needed

- CPR if needed

When able

- Monitor HR, BP, RR, SpO₂
- Give O₂
- Support airway
- IV access - adults + hypotensive children

If hypotensive

- Give IV sodium chloride 0.9%
20 mL/kg **RAPIDLY**

Adrenaline (epinephrine) doses

Age (years)	Weight (kg)	Adrenaline 1:1,000
< 1	< 7.5	0.1 mL
1–2	10	
2–3	15	0.15 mL
4–6	20	0.2 mL
7–10	30	0.3 mL
10–12	40	0.4 mL
> 12–adult	> 50	0.5 mL

Additional measures MO/NP may consider

- Adrenaline (epinephrine) infusion - on advice of emergency medicine/critical care specialist
- If upper airway obstruction - nebulised adrenaline (epinephrine) ± intubation/cricothyrotomy
- If persistent hypotension/shock - sodium chloride 0.9% (max. 50 mL/kg in first 30 minutes)
- If persistent wheeze - bronchodilators, prednisolone or hydrocortisone

For detailed management, see [Anaphylaxis, p. 82](#)

